

Application Note: Intramolecular Photocyclization of Substituted Diallylamines

Author: BenchChem Technical Support Team. **Date:** April 2026

Compound of Interest

Compound Name: *1-Methyl-3-azabicyclo[3.2.0]heptane*
Cat. No.: *B13526488*

[Get Quote](#)

Abstract & Strategic Utility

This guide details the synthesis of functionalized pyrrolidines via the intramolecular photocyclization of substituted diallylamines.[1] Unlike thermal methods, this protocol utilizes Photoinduced Electron Transfer (PET) to generate reactive

-amino radicals under mild conditions.[1]

Why this matters:

- Scaffold Relevance: Pyrrolidines are ubiquitous pharmacophores in drug discovery (e.g., kainoids, proline derivatives).[1]
- Mechanistic Advantage: This method bypasses the need for harsh bases or toxic tin hydrides, using light to drive the thermodynamically uphill formation of C-C bonds.[1]
- Regiocontrol: The radical mechanism allows for predictable 5-exo-trig cyclizations, enabling the construction of quaternary centers often difficult to access via classical nucleophilic substitution.

Mechanistic Principles (The "Why")

The success of this reaction hinges on the oxidative generation of

α -amino radicals. The amine nitrogen acts as an electron donor, while a photosensitizer (Sens) acts as the electron acceptor.^[1]

The PET Cascade

- Excitation: The photosensitizer (e.g., 1,4-Dicyanonaphthalene [DCN]) absorbs light, reaching its excited singlet state (S_1).^[1]
- Single Electron Transfer (SET): The excited sensitizer oxidizes the diallylamine (donor), creating an Amine Radical Cation ($DA^{\cdot+}$) and a Sensitizer Radical Anion ($Sens^{\cdot-}$).^[1]
- Activation: The acidity of the α -C-H protons increases dramatically (pKa drops from ~40 to ~10).^[1]
- Radical Generation: Deprotonation (or desilylation, see Expert Insight below) yields the neutral α -amino radical.^[1]
- Cyclization: The carbon-centered radical attacks the pendant alkene (5-exo-trig), forming the ring.^[1]

Expert Insight: The Silyl "Auxiliary"

While simple alkyl amines work,

α -trimethylsilyl (TMS) substituted amines are superior substrates.^[1]

- Causality: The C-Si bond overlaps hyperconjugatively with the semi-occupied p-orbital of the nitrogen radical cation.

- Result: Selective cleavage of the C-Si bond (desilylation) is faster and more regioselective than deprotonation, preventing side reactions and increasing yield.[1]

Mechanistic Pathway Diagram[1][2]

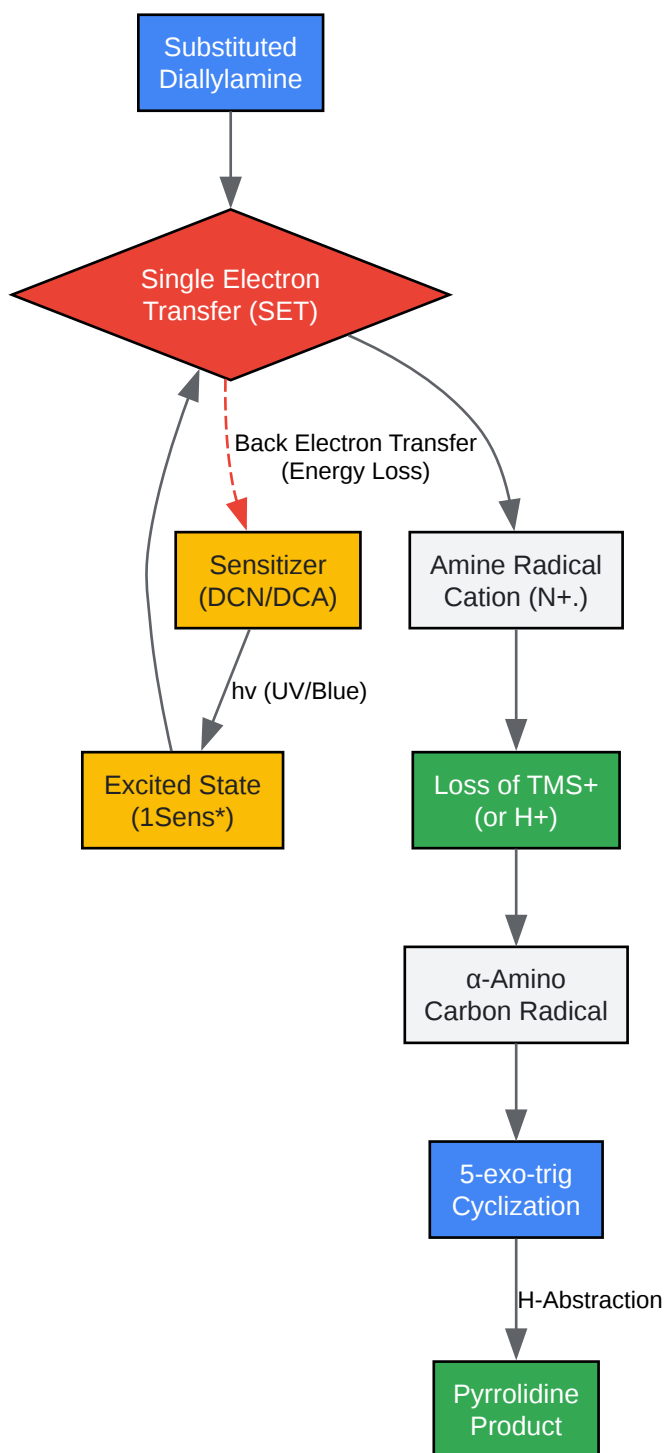

[Click to download full resolution via product page](#)

Caption: Figure 1. The PET pathway.[1][2][3][4][5] Note the critical competition between productive desilylation/deprotonation and non-productive Back Electron Transfer (BET).[1]

Experimental Design Strategy

Solvent Selection: The Polarity Paradox[1]

- Requirement: You need a polar solvent to stabilize the Solvent Separated Ion Pair (SSIP) formed after SET.[1] If the solvent is too non-polar, the radical ions recombine (Back Electron Transfer) before reaction occurs.[1]
- Recommendation: Acetonitrile (MeCN) or MeCN:H₂O (9:1).[1] The water component is crucial when using non-silylated amines to facilitate proton transfer.[1]

Photosensitizers

| Sensitizer | | E (V vs SCE) | Usage Case |
|------------------------------|----------------|-----------------|--|
| 1,4-Dicyanonaphthalene (DCN) | ~300-350 nm | -1.28 V | Standard. Robust, easy to remove. |
| 9,10-Dicyanoanthracene (DCA) | ~400 nm | -0.89 V | Use for amines with lower oxidation potentials. |
| Ru(bpy) | ~450 nm (Blue) | Variable | Modern visible-light variant (requires specific optimization). |

Detailed Protocol: DCN-Sensitized Cyclization

Target: Cyclization of N-benzyl-N-(trimethylsilylmethyl)-2-phenylallylamine to 3-benzyl-4-phenylpyrrolidine derivative.

Reagents & Equipment

- Substrate: 1.0 mmol substituted diallylamine.

- Sensitizer: 1,4-Dicyanonaphthalene (DCN) (0.1 - 0.2 mmol, 10-20 mol%).
- Solvent: HPLC-grade Acetonitrile (100 mL).
- Light Source: 450W Hanovia Medium Pressure Mercury Lamp (with Pyrex filter to cut off <280 nm) OR 365 nm High-Power LED.
- Vessel: Pyrex immersion well reactor or quartz tubes (if using 254 nm, though Pyrex is safer for DCN).

Step-by-Step Workflow

- Preparation (The "Dark" Phase):
 - Dissolve the amine (1.0 mmol) and DCN (0.2 mmol) in 100 mL Acetonitrile.
 - Concentration Control: Keep concentration dilute (~10 mM) to favor intramolecular cyclization over intermolecular polymerization.[1]
- Degassing (CRITICAL):
 - Oxygen is a radical scavenger and a triplet quencher.[1]
 - Sparge the solution with dry Nitrogen or Argon for at least 30 minutes.[1]
 - Validation: If the solution turns yellow/brown immediately upon irradiation, oxygen removal was insufficient (oxidative degradation).[1]
- Irradiation:
 - Place the reaction vessel in the photoreactor.
 - Turn on cooling water (maintain < 25°C).[1]
 - Irradiate.[1][6][7]
 - Monitoring: Check TLC every 30 minutes.[1] The amine spot will disappear; the DCN spot should remain largely unchanged (catalytic).[1]

- Workup:
 - Evaporate solvent under reduced pressure.[1]
 - Purification: The residue contains the product and the sensitizer.[1]
 - DCN is non-polar.[1] Flash chromatography (Hexane/EtOAc) usually elutes DCN first, followed by the amine product.[1]

Experimental Workflow Diagram



[Click to download full resolution via product page](#)

Caption: Figure 2. Operational workflow. Degassing is the primary failure point; ensure rigorous sparging.[1]

Troubleshooting & Optimization

| Issue | Probable Cause | Corrective Action |
|---------------------|---|--|
| No Reaction | BET (Back Electron Transfer) is faster than reaction. | Increase solvent polarity (add 10% H ₂ O or MeOH).[1] Switch to silylated amine precursor.[1] |
| Polymerization | Concentration too high.[1] | Dilute reaction to < 10 mM.[1] |
| Low Yield | Oxygen quenching.[1] | Perform "Freeze-Pump-Thaw" cycles (x3) instead of simple sparging. |
| Product is unstable | Acidic silica degradation.[1] | Add 1% Triethylamine to the eluent during chromatography. [1] |

Scope and Limitations (Data Summary)

The following table summarizes expected yields based on substituent electronic effects (based on Pandey et al. and recent literature).

| Substrate Type | Substituent (Alkene) | Substituent (-N) | Yield (%) | Notes |
|--------------------|----------------------|------------------|-----------|--|
| Simple Diallyl | H | H | 40-50% | Slow; competitive polymerization. |
| Activated | Phenyl (Styrenyl) | H | 75-85% | Radical stabilized by phenyl ring. |
| Silyl-Activated | H | TMS | 80-90% | Rapid desilylation drives equilibrium. |
| Electron-Deficient | Ester (Acrylate) | H | < 30% | Mismatched polarity; PET inhibited. |

References

- Pandey, G., et al. "Photoinduced Electron Transfer (PET) promoted cyclizations of amines: A general method for the synthesis of nitrogen heterocycles." [1] *Tetrahedron*, 1989. [1]
- Mariano, P. S. "Mechanistic aspects of the photoinduced electron transfer reactions of amines and related systems." *Accounts of Chemical Research*, 1983. [1]
- Yoon, T. P. "Visible light photocatalysis as a greener approach to photochemical synthesis." [1] *Nature*, 2008. [1] (Context for modern visible light adaptation).
- Schindler, C. S. "Synthesis of Azetidines via Visible-Light-Mediated Intermolecular [2+2] Photocycloadditions." [1] *Science*, 2014. [1] (Relevant for [2+2] vs cyclization competition).

Need Custom Synthesis?

BenchChem offers custom synthesis for rare earth carbides and specific isotopic labeling.

Email: info@benchchem.com or [Request Quote Online](#).

Sources

- [1. youtube.com](https://www.youtube.com) [[youtube.com](https://www.youtube.com)]
- [2. acs.figshare.com](https://www.acs.figshare.com) [[acs.figshare.com](https://www.acs.figshare.com)]
- [3. Photoinduced-electron-transfer chemistry: from studies on PET processes to applications in natural product synthesis - PubMed](#) [pubmed.ncbi.nlm.nih.gov]
- [4. mdpi.com](https://www.mdpi.com) [[mdpi.com](https://www.mdpi.com)]
- [5. chemrxiv.org](https://chemrxiv.org) [chemrxiv.org]
- [6. researchgate.net](https://www.researchgate.net) [[researchgate.net](https://www.researchgate.net)]
- [7. Visible-Light-Induced Metal- and Photocatalyst-Free Radical Cascade Cyclization of Cinnamamides for Synthesis of Functionalized Dihydroquinolinones - PubMed](#) [pubmed.ncbi.nlm.nih.gov]
- To cite this document: BenchChem. [Application Note: Intramolecular Photocyclization of Substituted Diallylamines]. BenchChem, [2026]. [Online PDF]. Available at: [<https://www.benchchem.com/product/b13526488/docs#application-note-intramolecular-photocyclization-of-substituted-diallylamines>]

Disclaimer & Data Validity:

The information provided in this document is for Research Use Only (RUO) and is strictly not intended for diagnostic or therapeutic procedures. While BenchChem strives to provide accurate protocols, we make no warranties, express or implied, regarding the fitness of this product for every specific experimental setup.

Technical Support: The protocols provided are for reference purposes. Unsure if this reagent suits your experiment?

Need Industrial/Bulk Grade? [Request Custom Synthesis Quote](#)

BenchChem

Our mission is to be the trusted global source of essential and advanced chemicals, empowering scientists and researchers to drive progress in science and industry.

Contact

Address: 3281 E Guasti Rd

Ontario, CA 91761, United States

Phone: (601) 213-4426

Email: info@benchchem.com

[Contact our Ph.D. Support Team for a compatibility check](#)