

Technical Support Center: Optimizing Base Selection for Ethyl Chloroacetate Alkylation

Author: BenchChem Technical Support Team. **Date:** April 2026

Compound of Interest

Compound Name: Ethyl (4-carbamoylphenyl)glycinate

Cat. No.: B13510515

[Get Quote](#)

Welcome to the technical support guide for optimizing alkylation reactions involving ethyl chloroacetate. As a versatile reagent in organic synthesis, its successful application hinges on the careful selection of reaction parameters, most critically, the choice of base.^{[1][2]} This guide, structured in a question-and-answer format, provides field-proven insights and troubleshooting strategies to help you navigate the complexities of your experiments and achieve optimal outcomes.

Frequently Asked Questions (FAQs)

Q1: What is the fundamental role of the base in ethyl chloroacetate alkylation?

A base is used to deprotonate a nucleophile, which can be a carbon- or heteroatom-centered species (like an amine, alcohol, or thiol). In the context of C-alkylation, the base removes an acidic α -proton from a carbonyl compound, generating a nucleophilic enolate.^{[3][4]} This enolate then attacks the electrophilic carbon of ethyl chloroacetate in a nucleophilic substitution (SN2) reaction, forming a new carbon-carbon bond.^{[4][5]} For N- or O-alkylation, the base simply deprotonates the amine or alcohol to increase its nucleophilicity.

Q2: How does the pKa of the base and my nucleophile determine the reaction's success?

The relationship between the pKa of the base and the acidic proton of your nucleophile is crucial for efficient deprotonation. A fundamental principle is that the base's conjugate acid must have a higher pKa than the acidic proton of the substrate. This ensures the equilibrium favors the formation of the deprotonated nucleophile (e.g., the enolate).

- For C-H acids (enolate formation): The α -protons of esters like ethyl chloroacetate are weakly acidic, with a pKa around 23-25.^[3] To achieve complete and irreversible deprotonation to form the enolate in high concentration, a very strong base with a conjugate acid pKa > 25 is required.^[3]
- For N-H or O-H acids: The acidity of these protons varies widely. A base should be chosen that is strong enough to deprotonate the nucleophile but not so strong that it promotes unwanted side reactions.

Q3: What are the common classes of bases used, and when should I choose one over another?

Bases for this alkylation can be broadly categorized as strong, non-nucleophilic bases and weaker inorganic bases.

- Strong, Non-Nucleophilic Bases: These include sodium hydride (NaH), lithium diisopropylamide (LDA), and sodium amide (NaNH₂).^[3] They are ideal for generating enolates from weakly acidic carbon centers because they ensure rapid and complete conversion, minimizing side reactions.^{[3][6]} NaH is often used in aprotic polar solvents like DMF or THF.^[7]
- Weaker Inorganic Bases: Carbonates such as potassium carbonate (K₂CO₃) and sodium carbonate (Na₂CO₃), and hydroxides are commonly used, especially for N- and O-alkylations.^{[4][7]} They are generally safer, less expensive, and easier to handle than hydrides or amides. K₂CO₃ in solvents like DMF or acetone is a very common system.^{[4][6]}
^[7]

- Phase-Transfer Catalysis (PTC): For reactions in biphasic systems (e.g., aqueous NaOH and an organic solvent), a phase-transfer catalyst like a quaternary ammonium salt (e.g., Aliquat 336® or TBAB) can be used.[8][9][10] The catalyst transports the hydroxide or other anion into the organic phase to react, offering a mild and efficient alternative to strong bases in anhydrous solvents.[9][11]

Q4: How does solvent choice impact the alkylation reaction?

The solvent plays a critical role in solubilizing reactants, influencing the reactivity of the base and nucleophile, and affecting the reaction rate.

- Aprotic Polar Solvents (DMF, DMSO, Acetonitrile, THF): These are the most common choices.[7] They effectively solvate the cation of the base (e.g., Na⁺, K⁺) while leaving the anion (the active base) relatively "naked" and more reactive. DMF is particularly effective for many alkylations using carbonate bases.[4][7]
- Aprotic Non-Polar Solvents (Toluene, Hexane): These are generally used with very strong bases like LDA or when employing phase-transfer catalysis.
- Protic Solvents (Ethanol, Water): These are generally avoided when using strong bases like NaH, as they will be deprotonated, consuming the base. They can also participate in side reactions like ester hydrolysis.[6][12]

Troubleshooting Guide

Problem: My reaction yield is low or zero.

This is a common issue that can stem from several factors related to reactants, reagents, or conditions.[6]

Potential Cause	Explanation & Solution
Inappropriate Base Strength	<p>The chosen base may be too weak to deprotonate your nucleophile effectively.</p> <p>Solution: Switch to a stronger base. If you are using K_2CO_3 for a C-alkylation, consider moving to NaH or LDA.[6][7] Ensure the pKa of the base's conjugate acid is significantly higher than your substrate's acidic proton.</p>
Inactive Nucleophile	<p>The nucleophilicity of your substrate might be inherently low.[6] Solution: Use a stronger base to increase the concentration of the deprotonated, more nucleophilic species. Alternatively, increasing the reaction temperature may provide the necessary activation energy.[6]</p>
Presence of Water	<p>Water can hydrolyze the ester group of ethyl chloroacetate or your product, especially under basic conditions.[6] It will also quench strong bases like NaH. Solution: Ensure all glassware is flame-dried or oven-dried. Use anhydrous solvents and run the reaction under an inert atmosphere (N_2 or Ar).[6][12]</p>
Poor Reagent Quality	<p>Ethyl chloroacetate can degrade over time. The base (especially NaH) can lose activity if improperly stored. Solution: Use freshly opened or properly stored reagents. If possible, purify ethyl chloroacetate by distillation before use.</p>

Problem: I'm observing multiple byproducts and low selectivity.

The formation of side products often points to issues with reaction control, base choice, or stoichiometry.

Potential Cause	Explanation & Solution
Over-alkylation	<p>If your newly alkylated product is still nucleophilic, it can react again with ethyl chloroacetate.^[6] This is common with primary amines or active methylene compounds.</p> <p>Solution: Use a stoichiometric amount (or a slight excess, e.g., 1.1 equivalents) of ethyl chloroacetate.^[6] Adding the alkylating agent dropwise at a low temperature can also help control the reaction.</p>
Hydrolysis	<p>As mentioned, water can lead to the formation of chloroacetic acid and ethanol.^{[6][13][14]}</p> <p>Solution: Maintain strictly anhydrous conditions throughout the reaction and workup.^{[6][12]}</p>
Base-Induced Elimination	<p>Strong, sterically hindered bases can sometimes promote elimination reactions if the substrate allows for it. Solution: Consider using a milder base or a different solvent system.</p> <p>Phase-transfer catalysis can sometimes improve selectivity by using a low concentration of the active base in the organic phase.^[8]</p>
C- vs. O-Alkylation	<p>Enolates are ambident nucleophiles and can react at either the carbon or the oxygen atom.</p> <p>Solution: C-alkylation is generally favored under kinetic control (strong, hindered bases like LDA at low temperatures) and in polar aprotic solvents. O-alkylation can become more competitive under thermodynamic control or with changes in the cation and solvent.</p>

Problem: The reaction is very slow or stalls completely.

A sluggish reaction indicates that the activation energy barrier is not being overcome efficiently.

Potential Cause	Explanation & Solution
Low Temperature	Many alkylations require heating to proceed at a reasonable rate.[6] Solution: If the reaction is slow at room temperature, consider gently heating the mixture (e.g., to 60-80 °C).[6] Monitor by TLC to ensure the product is stable at higher temperatures.
Poor Solubility	If the base or nucleophile is not sufficiently soluble in the chosen solvent, the reaction will be slow. Solution: Switch to a more appropriate solvent (e.g., from acetone to DMF for better solubility of salts).[7] For biphasic systems, vigorous stirring is essential.
SN2 Reaction Hindrance	The chloride on ethyl chloroacetate is a good leaving group, but if your nucleophile is very sterically hindered, the SN2 reaction will be slow. Solution: Consider using ethyl bromoacetate or iodoacetate, which have better leaving groups. Adding a catalytic amount of sodium or potassium iodide (KI) can facilitate the reaction via an in situ Finkelstein reaction, converting the chloroacetate to the more reactive iodoacetate.[7]

Data Summary: Common Bases for Alkylation

The following table provides a guide to selecting a base based on its strength and typical application.

Base	Abbreviation	pKa (Conjugate Acid)	Typical Solvents	Comments & Use Case
Sodium Hydride	NaH	~36	THF, DMF	Strong, non-nucleophilic. Ideal for complete deprotonation of carbon acids to form enolates. Requires anhydrous conditions.[3][7]
Lithium Diisopropylamide	LDA	~36	THF, Hexane	Very strong, sterically hindered. Excellent for kinetic enolate formation. Typically prepared in situ at low temperatures.[3][15]
Potassium Carbonate	K ₂ CO ₃	10.3	DMF, Acetone, CH ₃ CN	Mild, inexpensive base. Widely used for N- and O-alkylation and for C-alkylation of more acidic substrates (e.g., β-keto esters).[4][6][7]
Sodium Carbonate	Na ₂ CO ₃	10.3	DMF, CH ₃ CN	Similar to K ₂ CO ₃ , but often less

reactive due to lower solubility.
[7]

Sodium Ethoxide

NaOEt

16

Ethanol

Strong, nucleophilic base. Used for deprotonating substrates more acidic than ethanol. Can lead to transesterification.[4]

Cesium Carbonate

Cs₂CO₃

10.3

DMF

Highly effective due to the "cesium effect," which involves better solubility and generation of a more reactive "naked" anion.[7]

Experimental Protocols

Protocol 1: General N-Alkylation using Potassium Carbonate

This protocol provides a general guideline for the alkylation of a primary or secondary amine with ethyl chloroacetate using potassium carbonate.[6]

- Preparation: To a flame-dried round-bottom flask under an inert atmosphere (N₂ or Ar), add the amine (1.0 eq.), anhydrous potassium carbonate (1.5-2.0 eq.), and a suitable solvent (e.g., DMF or acetone, to a concentration of ~0.1-0.5 M).[4][6]

- Addition of Reagent: Stir the suspension at room temperature. Add ethyl chloroacetate (1.1 eq.) dropwise to the mixture.[6]
- Reaction: Heat the reaction mixture to the desired temperature (e.g., 60-80 °C) and monitor the progress by TLC. The reaction may take several hours to reach completion.[6]
- Workup: After the reaction is complete, cool the mixture to room temperature and filter off the inorganic salts. Concentrate the filtrate under reduced pressure.[6]
- Extraction: Dissolve the residue in a suitable organic solvent (e.g., ethyl acetate) and wash with water (2x) and brine (1x).[6]
- Drying and Concentration: Dry the organic layer over anhydrous sodium sulfate or magnesium sulfate, filter, and concentrate in vacuo.[6]
- Purification: Purify the crude product by column chromatography on silica gel or by distillation/recrystallization to afford the pure N-alkylated product.[6]

Protocol 2: C-Alkylation of a Ketone using Sodium Hydride

This protocol outlines the alkylation of a ketone via its enolate using the strong base sodium hydride.

- Preparation: To a flame-dried, three-neck round-bottom flask equipped with a dropping funnel, thermometer, and nitrogen inlet, add NaH (1.1 eq., 60% dispersion in mineral oil). Wash the NaH with anhydrous hexane (2x) to remove the oil, then carefully decant the hexane. Add anhydrous THF or DMF via cannula. Cool the suspension to 0 °C.
- Enolate Formation: Dissolve the ketone (1.0 eq.) in anhydrous THF/DMF and add it dropwise to the NaH suspension, maintaining the temperature at 0 °C. Stir for 30-60 minutes at 0 °C, then allow it to warm to room temperature for 1 hour to ensure complete deprotonation (hydrogen evolution will cease).
- Alkylation: Cool the enolate solution back to 0 °C. Add ethyl chloroacetate (1.05 eq.) dropwise, ensuring the temperature does not rise significantly.

- Reaction: Allow the reaction to warm to room temperature and stir until TLC analysis indicates the consumption of the starting material. Gentle heating may be required.
- Workup: Carefully quench the reaction by slowly adding a saturated aqueous solution of ammonium chloride (NH_4Cl) at $0\text{ }^\circ\text{C}$.
- Extraction & Purification: Transfer the mixture to a separatory funnel, add diethyl ether or ethyl acetate, and separate the layers. Extract the aqueous layer with the organic solvent (2x). Combine the organic layers, wash with brine, dry over anhydrous Na_2SO_4 , filter, and concentrate. Purify the crude product by column chromatography.[4]

Visualizations

General Alkylation Mechanism

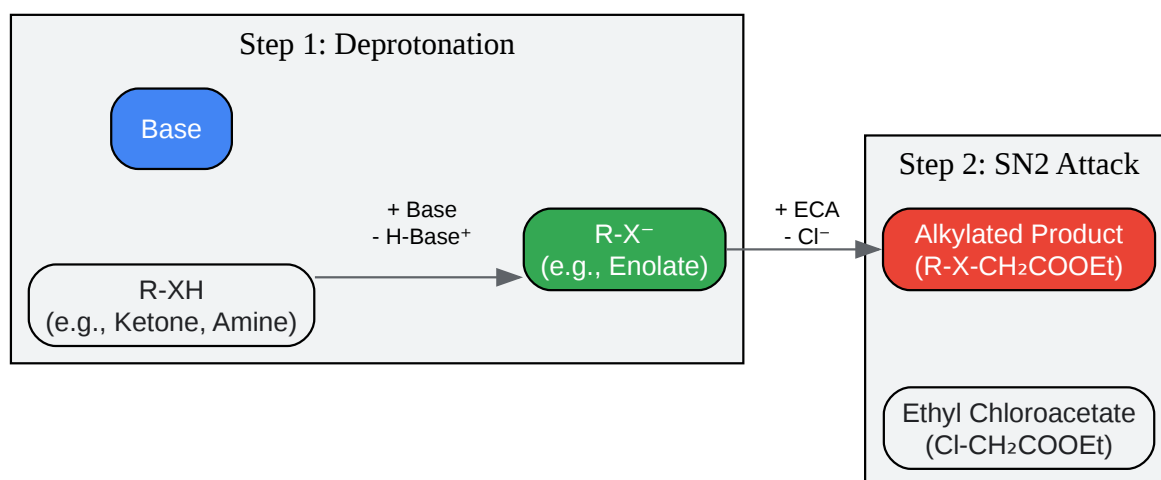

[Click to download full resolution via product page](#)

Caption: General two-step mechanism for ethyl chloroacetate alkylation.

Troubleshooting Workflow

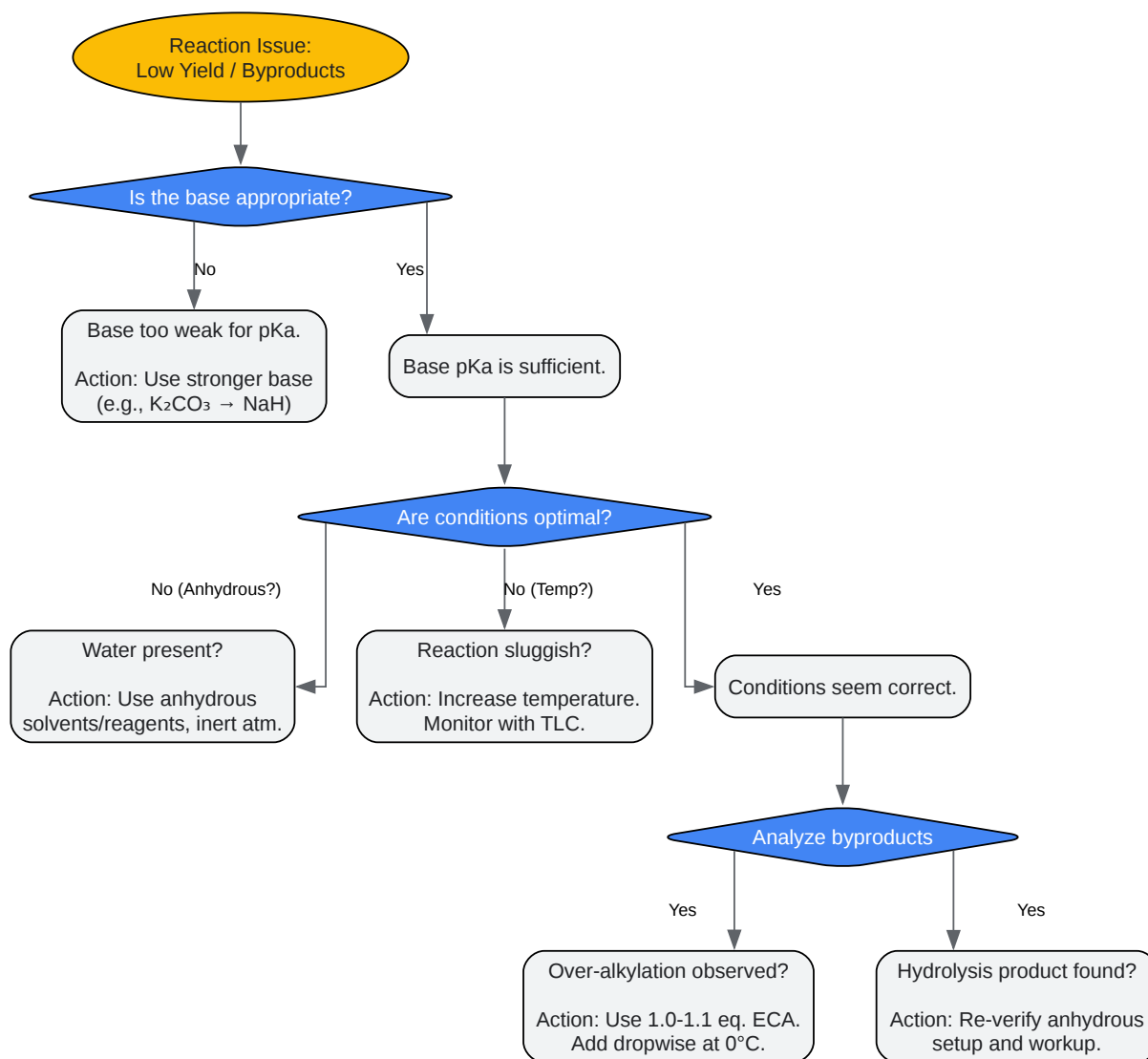

[Click to download full resolution via product page](#)

Caption: Decision tree for troubleshooting common alkylation issues.

References

- ResearchGate. (2012). Can anyone recommend how to do a reaction with chloroacetic acid or ethyl chloroacetate?. Available at: [\[Link\]](#)
- Chemistry LibreTexts. (2020). 23.2: Enols, Enolate Ions and Tautomerization. Available at: [\[Link\]](#)
- PTC Organics. (n.d.). Industrial Phase-Transfer Catalysis. Available at: [\[Link\]](#)
- ScienceDirect. (2025). Process alternatives for the production of ethyl chloroacetate by reactive distillation. Available at: [\[Link\]](#)
- CRDEEP Journals. (n.d.). Phase-Transfer Catalysis in Organic Syntheses. Available at: [\[Link\]](#)
- ResearchGate. (2025). Alkylation of pyrazoles with ethyl chloroacetate under phase-transfer catalysis and hydrolysis of the esters obtained. Available at: [\[Link\]](#)
- Beilstein Journal of Organic Chemistry. (2022). Electrogenated base-promoted cyclopropanation using alkyl 2-chloroacetates. Available at: [\[Link\]](#)
- Scribd. (2017). Enolate Chemistry: pKa and Selectivity. Available at: [\[Link\]](#)
- HighMountain Chem. (2023). Ethyl Chloroacetate: Complete Guide. Available at: [\[Link\]](#)
- Google Patents. (1948). US2452350A - Method of preparing alkyl esters of chloroacetic acid.
- Master Organic Chemistry. (2022). Enolates - Formation, Stability, and Simple Reactions. Available at: [\[Link\]](#)
- Canadian Journal of Chemistry. (1979). The enol content of simple carbonyl compounds: an approach based upon pKa estimation. Available at: [\[Link\]](#)
- BioMed Research International. (2022). A Minireview of Phase-Transfer Catalysis and Recent Trends. Available at: [\[Link\]](#)
- Wikipedia. (n.d.). Ethyl chloroacetate. Available at: [\[Link\]](#)

- YouTube. (2023). Make Ethyl Chloroacetate Synthesis with Dean Stark. Available at: [[Link](#)]
- YouTube. (2022). Ethyl Chloroacetate a Deadly Precursor to Many Pharmaceuticals. Available at: [[Link](#)]
- PrepChem.com. (2018). Preparation of ethyl chloroacetate. Available at: [[Link](#)]

Need Custom Synthesis?

BenchChem offers custom synthesis for rare earth carbides and specific isotopic labeling.

Email: info@benchchem.com or [Request Quote Online](#).

Sources

- 1. Ethyl Chloroacetate: Complete Guide - HighMountain Chem [highmountainco.com]
- 2. Page loading... [wap.guidechem.com]
- 3. chem.libretexts.org [chem.libretexts.org]
- 4. pdf.benchchem.com [pdf.benchchem.com]
- 5. vanderbilt.edu [vanderbilt.edu]
- 6. pdf.benchchem.com [pdf.benchchem.com]
- 7. researchgate.net [researchgate.net]
- 8. phasetransfer.com [phasetransfer.com]
- 9. crdeepjournal.org [crdeepjournal.org]
- 10. alfa-chemistry.com [alfa-chemistry.com]
- 11. biomedres.us [biomedres.us]
- 12. researchgate.net [researchgate.net]
- 13. researchgate.net [researchgate.net]
- 14. ETHYL CHLOROACETATE | CAMEO Chemicals | NOAA [cameochemicals.noaa.gov]
- 15. scribd.com [scribd.com]
- To cite this document: BenchChem. [Technical Support Center: Optimizing Base Selection for Ethyl Chloroacetate Alkylation]. BenchChem, [2026]. [Online PDF]. Available at:

[<https://www.benchchem.com/product/b13510515/docs#technical-support-center-optimizing-base-selection-for-ethyl-chloroacetate-alkylation>]

Disclaimer & Data Validity:

The information provided in this document is for Research Use Only (RUO) and is strictly not intended for diagnostic or therapeutic procedures. While BenchChem strives to provide accurate protocols, we make no warranties, express or implied, regarding the fitness of this product for every specific experimental setup.

Technical Support: The protocols provided are for reference purposes. Unsure if this reagent suits your experiment?

Need Industrial/Bulk Grade? [Request Custom Synthesis Quote](#)

BenchChem

Our mission is to be the trusted global source of essential and advanced chemicals, empowering scientists and researchers to drive progress in science and industry.

Contact

Address: 3281 E Guasti Rd
Ontario, CA 91761, United States
Phone: (601) 213-4426
Email: info@benchchem.com

[Contact our Ph.D. Support Team for a compatibility check](#)