

Application Note: Regioselective Polymerization of (R)-4-Chlorostyrene Oxide[1][2]

Author: BenchChem Technical Support Team. **Date:** May 2026

Compound of Interest

Compound Name: (R)-4-Chlorostyrene oxide

CAS No.: 21019-51-2

Cat. No.: B135846

[Get Quote](#)

Executive Summary & Mechanistic Logic

(R)-4-Chlorostyrene oxide presents a unique dual-functionality:

- The Chiral Epoxide: Allows for the formation of isotactic polyethers or alternating polycarbonates.[2]
- The p-Chloro Handle: An aryl chloride available for post-polymerization modification (e.g., via Buchwald-Hartwig coupling), unlike the unreactive phenyl ring of standard styrene oxide.[1][2]

The Regioselectivity Challenge

The polymerization mechanism dictates the stereochemical outcome.[2] The p-chloro group is electron-withdrawing (

), which deactivates the phenyl ring but increases the electrophilicity of the benzylic (

) carbon compared to unsubstituted styrene oxide.[2]

- Path A (

-Attack): Nucleophilic attack at the less hindered methylene carbon.[1][2]

- Mechanism:[3][4][5][6][7]

-like.

- Outcome:Retention of configuration at the chiral center.[2][8]

- Preferred Conditions: Anionic polymerization, sterically bulky catalysts.[1][2]

- Path B (

-Attack): Nucleophilic attack at the benzylic carbon.[1][2]

- Mechanism:[3][4][5][7]

-like / Carbocation character.[1][2]

- Outcome:Inversion (if concerted) or Racemization (if carbocation forms).[1][2]

- Preferred Conditions: Cationic polymerization, acid catalysis.[1][2]

Mechanistic Pathway Diagram[1][2][6][10]

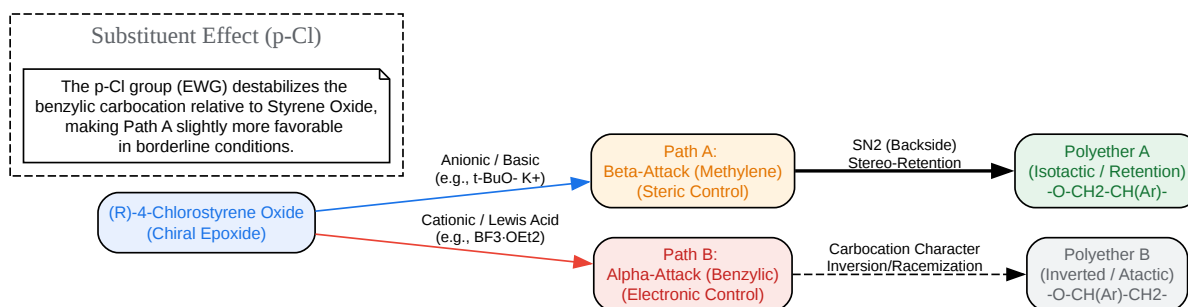

[Click to download full resolution via product page](#)

Figure 1: Regioselective pathways in the ring-opening polymerization of **(R)-4-chlorostyrene oxide**.^{[1][2]} Path A is preferred for maintaining optical purity.^[2]

Protocol A: Anionic Ring-Opening Polymerization (AROP)

Objective: Synthesis of semi-crystalline, optically active Poly(**(R)-4-chlorostyrene oxide**).^{[1][2]}

Mechanism: Anionic coordination with regioselective

-attack.^{[1][2]}

Materials & Reagents^{[2][10][11][12][13][14]}

- Monomer: **(R)-4-Chlorostyrene oxide** (>98% ee), dried over and vacuum distilled immediately before use.^{[1][2]}
- Initiator: Potassium tert-butoxide (t -BuOK) or Phosphazene base (t -BuP4) for faster rates.^{[1][2]}
- Solvent: THF (anhydrous) or Toluene (for slower, more controlled growth).^{[1][2]}
- Quenching Agent: Methanol containing HCl.^{[1][2]}

Experimental Workflow

- Inert Atmosphere: All steps must be performed in a glovebox or using strict Schlenk line techniques under Argon.
- Initiator Prep: Prepare a 0.1 M solution of t -BuOK in dry THF.^{[1][2]}
- Polymerization:
 - Charge a flame-dried Schlenk flask with THF (10 mL) and Monomer (1.54 g, 10 mmol).

- Equilibrate to 0°C (low temperature favors -attack regioselectivity).[1][2]
- Add Initiator solution (e.g., 0.1 mmol for target DP=100) via gastight syringe.[1][2]
- Observation: The solution may turn slight yellow.[2]
- Stir at 0°C for 4 hours, then allow to warm to room temperature for 24-48 hours.
- Termination: Add 0.5 mL of acidic methanol.
- Purification:
 - Precipitate the polymer into cold hexanes (the polymer is likely insoluble in non-polar alkanes due to the polar ether/chloro backbone).[2]
 - Re-dissolve in THF and re-precipitate twice to remove unreacted monomer.[1][2]
- Drying: Vacuum dry at 40°C for 24 hours.

Critical Parameter: Regiocontrol

To maximize isotacticity (retention of R-configuration), avoid high temperatures (>60°C) which can overcome the activation energy difference between

and

attack, leading to regio-errors (head-to-head defects).[1][2]

Protocol B: Alternating Copolymerization with

Objective: Synthesis of chiral Poly(4-chlorostyrene carbonate). Significance: This protocol utilizes

as a C1 feedstock.[1][2] The p-chloro group provides higher Tg compared to unsubstituted styrene carbonate.[1][2]

Catalyst System[2][4][6][9][10][11][13][14]

- Catalyst: (S,S)-SalenCo(III)-DNP (2,4-dinitrophenoxy) complex.[1][2]

- Why Chiral Catalyst? Even though the monomer is chiral, using a chiral catalyst ("matched" stereochemistry) significantly enhances regioselectivity towards kinetic resolution or perfect alternation.[2]
- Co-catalyst: Bis(triphenylphosphine)iminium chloride ([PPN]Cl).[1][2]

Experimental Workflow

- Reactor Setup: Use a high-pressure stainless steel autoclave (Parr reactor).[1][2]
- Loading:
 - In a glovebox, load (S,S)-SalenCo(III) catalyst (0.05 mol%) and [PPN]Cl (0.05 mol%) into the reactor.[1][2]
 - Add **(R)-4-Chlorostyrene oxide** (20 mmol).
 - Note: Solvent-free (bulk) conditions are often preferred for this reaction to maximize rate. [1][2]
- Pressurization:
 - Seal reactor and remove from glovebox.[1][2]
 - Pressurize with dry

to 2.0 MPa (approx 20 bar).
- Reaction:
 - Heat to 25°C - 40°C. Caution: Higher temperatures increase the risk of cyclic carbonate byproduct formation (thermodynamic sink) vs. linear polymer (kinetic product).[2]
 - Stir for 12-24 hours.
- Work-up:
 - Vent

slowly.[1][2]

- Dissolve the crude solid in minimal

. [1][2]

- Precipitate into acidic methanol to remove catalyst residues (Co salts are toxic and colored).[1][2]
- Dry under vacuum.[1][2]

Characterization & Data Analysis

NMR Spectroscopy (and)

Regio-regularity is the primary quality metric.[1][2]

Feature	Chemical Shift (, ppm)	Interpretation
Polyether Backbone		
-CH (Methine)	4.5 - 5.0	Shifted downfield due to Cl-Phenyl ring.[1][2]
-CH (Methylene)	3.4 - 3.8	Diastereotopic protons if isotactic.[1][2]
Polycarbonate		
Carbonate C=O	~153 - 154	Diagnostic of carbonate linkage (vs ether).[1][2]
Cyclic Carbonate	~154.5	Impurity. Sharp singlet distinct from polymer broad peak.[1][2]

Thermal Properties (DSC)

The p-chloro substituent increases chain stiffness.[1][2]

- Tg (Polyether): Expected ~80-90°C (higher than PEO, similar to polystyrene).[1][2]
- Tg (Polycarbonate): Expected ~120-130°C.[1][2]
- Tm: Only observed if high regioregularity leads to crystallization.[1][2]

Troubleshooting & Optimization

Problem: Low Molecular Weight / Broad PDI

- Cause: Chain transfer to monomer.[1][2] The benzylic proton is somewhat acidic.[2]
- Solution: Lower the reaction temperature (Protocol A). In Protocol B, increase pressure to favor insertion over back-biting.[1][2]

Problem: Cyclic Carbonate Formation (Protocol B)

- Cause: "Back-biting" of the alkoxide chain end on the carbonate linkage.[2]
- Solution: Lower temperature and reduce reaction time. Ensure catalyst/co-catalyst ratio is optimized (excess co-catalyst can promote depolymerization).[1][2]

Problem: Loss of Optical Activity

- Cause: Attack at the
-carbon (benzylic) causing inversion or racemization.[1][2]
- Solution: Switch to a bulkier initiator/catalyst that cannot sterically access the
-carbon, forcing attack at the
-methylene.[1][2]

References

- Regioselectivity in Epoxide Polymerization
 - Mechanistic basis of anionic vs c

- Source: (General Reference for ROP mechanisms).[1][2]
- Cobalt-Salen Catalyzed Copolymerization
 - Specifics on Styrene Oxide/CO₂ copolymeriz
 - Source: [1][2]
- Substituent Effects in Styrene Oxide Derivatives
 - Impact of electron-withdrawing groups on epoxide reactivity.[1][2]
 - Source: [1][2]
- Properties of (R)
 - Physical data and synthesis precursors.[2]
 - Source: [1][2]

(Note: Specific literature on the homopolymerization of the pure (R)-4-Cl enantiomer is sparse; protocols are derived from established methodologies for (R)-Styrene Oxide and 4-Chlorostyrene Oxide analogues.)[1][2]

Need Custom Synthesis?

BenchChem offers custom synthesis for rare earth carbides and specific isotopic labeling.

Email: info@benchchem.com or [Request Quote Online](#).

Sources

- [1. 4-Chlorostyrene oxide | C₈H₇ClO | CID 197010 - PubChem \[pubchem.ncbi.nlm.nih.gov\]](#)
- [2. Study on the Mechanism of a Side Coupling Reaction during the Living Anionic Copolymerization of Styrene and 1-\(Ethoxydimethylsilylphenyl\)-1-phenylethylene \(DPE-SiOEt\) - PMC \[pmc.ncbi.nlm.nih.gov\]](#)
- [3. chem.libretexts.org \[chem.libretexts.org\]](#)

- [4. US5493062A - Process for preparing 4-hydroxystyrene - Google Patents \[patents.google.com\]](#)
- [5. chemistry.stackexchange.com \[chemistry.stackexchange.com\]](#)
- [6. Ring-opening polymerisation of l- and rac-lactide using group 4 permethylpentalene aryloxides and alkoxides - Dalton Transactions \(RSC Publishing\) \[pubs.rsc.org\]](#)
- [7. researchgate.net \[researchgate.net\]](#)
- [8. Alternating copolymerization of CO2 and styrene oxide with Co\(iii\)-based catalyst systems: differences between styrene oxide and propylene oxide - Energy & Environmental Science \(RSC Publishing\) \[pubs.rsc.org\]](#)
- [To cite this document: BenchChem. \[Application Note: Regioselective Polymerization of \(R\)-4-Chlorostyrene Oxide\[1\]\[2\]\]. BenchChem, \[2026\]. \[Online PDF\]. Available at: \[https://www.benchchem.com/product/b135846/docs#application-note-regioselective-polymerization-of-r-4-chlorostyrene-oxide-1-2\]](#)

Disclaimer & Data Validity:

The information provided in this document is for Research Use Only (RUO) and is strictly not intended for diagnostic or therapeutic procedures. While BenchChem strives to provide accurate protocols, we make no warranties, express or implied, regarding the fitness of this product for every specific experimental setup.

Technical Support: The protocols provided are for reference purposes. Unsure if this reagent suits your experiment?

Need Industrial/Bulk Grade? [Request Custom Synthesis Quote](#)

BenchChem

Our mission is to be the trusted global source of essential and advanced chemicals, empowering scientists and researchers to drive progress in science and industry.

Contact

Address: 3281 E Guasti Rd

Ontario, CA 91761, United States

Phone: (601) 213-4426

Email: info@benchchem.com

Contact our Ph.D. Support Team for a compatibility check