

A Comparative Analysis of the Antioxidant Activities of Aminoguanidine and Methylguanidine

Author: BenchChem Technical Support Team. **Date:** December 2025

Compound of Interest

Compound Name: *Methylguanidine hydrochloride*

Cat. No.: *B135379*

[Get Quote](#)

For Researchers, Scientists, and Drug Development Professionals

This guide provides an objective comparison of the antioxidant properties of two structurally related guanidino compounds, aminoguanidine and methylguanidine. By presenting supporting experimental data, detailed methodologies, and visual representations of relevant pathways, this document aims to be a valuable resource for researchers investigating oxidative stress and developing novel therapeutic agents.

Executive Summary

Aminoguanidine consistently demonstrates superior direct radical scavenging activity across a range of reactive oxygen species (ROS) when compared to methylguanidine. While both compounds exhibit inhibitory effects on inducible nitric oxide synthase (iNOS), a key enzyme in the inflammatory cascade and a source of reactive nitrogen species, aminoguanidine is a significantly more potent inhibitor. The subsequent sections provide a detailed breakdown of the experimental evidence supporting these conclusions.

Data Presentation: Quantitative Comparison of Antioxidant Activities

The following table summarizes the quantitative data from a key comparative study utilizing a luminol-enhanced chemiluminescence assay to evaluate the direct scavenging activity of

aminoguanidine and methylguanidine against various reactive oxygen species.

Reactive Oxygen Species (ROS)	Concentration	Aminoguanidine (% Inhibition)	Methylguanidine (% Inhibition)
Hydrogen Peroxide (H ₂ O ₂)	1 mM	69 ± 0.7%	26 ± 1%
Hypochlorous Acid (HOCl)	1 mM	84 ± 0.3%	50 ± 1%
Hydroxyl Radical (•OH) (ferrous iron-induced)	1 mM	95 ± 0.5%	25 ± 1%
Peroxynitrite (ONOO ⁻)	10 mM	99 ± 0.1%	5 ± 0.2%

Data sourced from a luminol-enhanced chemiluminescence study.[1]

Furthermore, Electron Paramagnetic Resonance (EPR) studies have quantified the hydroxyl radical scavenging ability of aminoguanidine, reporting an IC₅₀ value of 6.5 mM.

Mechanisms of Antioxidant Action

Both aminoguanidine and methylguanidine exert their antioxidant effects through several mechanisms, including direct radical scavenging and modulation of enzymatic pathways.

Direct Radical Scavenging: As evidenced by the data above, aminoguanidine is a potent direct scavenger of various ROS, including hydrogen peroxide, hypochlorous acid, hydroxyl radicals, and peroxynitrite.[1] Methylguanidine also demonstrates direct scavenging activity, albeit to a lesser extent than aminoguanidine for the tested species.[1]

Inhibition of Nitric Oxide Synthase (NOS): A crucial mechanism contributing to the antioxidant and anti-inflammatory properties of both compounds is the inhibition of nitric oxide synthase, particularly the inducible isoform (iNOS). Overproduction of nitric oxide by iNOS can lead to the formation of the highly reactive and damaging peroxynitrite radical.

- Aminoguanidine is a well-established selective inhibitor of iNOS.[2][3][4]
- Methylguanidine also inhibits iNOS, but is considerably less potent than aminoguanidine.[5] It is estimated to be about 1-5% as potent as aminoguanidine in inhibiting the inducible isoform of NO synthase.[5]

Modulation of Antioxidant Enzymes: Studies in diabetic rat models have shown that aminoguanidine administration can restore the activities of key antioxidant enzymes such as superoxide dismutase (SOD), catalase (CAT), and glutathione peroxidase (GPx).[6][7] This suggests an indirect antioxidant effect by bolstering the endogenous antioxidant defense system. The effect of methylguanidine on these specific enzymes is less well-documented.

Experimental Protocols

Luminol-Enhanced Chemiluminescence Assay for ROS Scavenging

This protocol is based on the methodology used to directly compare the scavenging activity of aminoguanidine and methylguanidine against various ROS.[1]

Objective: To measure the ability of aminoguanidine and methylguanidine to scavenge hydrogen peroxide, hypochlorous acid, hydroxyl radicals, and peroxynitrite.

Materials:

- Luminol
- Aminoguanidine hydrochloride
- **Methylguanidine hydrochloride**
- Hydrogen peroxide (H₂O₂)
- Sodium hypochlorite (NaOCl)
- Ferrous sulfate (FeSO₄)
- Peroxynitrite (ONOO⁻)

- Phosphate-buffered saline (PBS)
- Chemiluminometer

Procedure:

- Preparation of Reagents: Prepare stock solutions of aminoguanidine and methylguanidine in PBS. Prepare working solutions of H₂O₂ (3.5 mM), NaOCl (50 μM), FeSO₄ (40 nM), and peroxyxynitrite (20 nM) in appropriate buffers immediately before use. Prepare a working solution of luminol.
- Assay:
 - In a luminometer tube, mix the respective ROS-generating system with either aminoguanidine, methylguanidine, or PBS (control) at the desired final concentrations.
 - Initiate the chemiluminescence reaction by adding the luminol solution.
 - Measure the light emission immediately using a chemiluminometer.
- Data Analysis: The percentage inhibition of the chemiluminescence signal in the presence of the test compound compared to the control is calculated to determine the scavenging activity.

Electron Paramagnetic Resonance (EPR) Spectroscopy for Hydroxyl Radical Scavenging

This protocol is adapted from studies evaluating the hydroxyl radical scavenging capacity of aminoguanidine.

Objective: To quantify the hydroxyl radical scavenging activity of aminoguanidine and methylguanidine.

Materials:

- Aminoguanidine hydrochloride
- **Methylguanidine hydrochloride**

- 5,5-dimethyl-1-pyrroline N-oxide (DMPO) as a spin trap
- Fenton's reagent (e.g., FeSO₄ and H₂O₂) to generate hydroxyl radicals
- Phosphate buffer
- EPR spectrometer

Procedure:

- **Sample Preparation:** In a test tube, mix the test compound (aminoguanidine or methylguanidine) at various concentrations with the spin trap DMPO in a phosphate buffer.
- **Radical Generation:** Initiate the generation of hydroxyl radicals by adding Fenton's reagent to the mixture.
- **EPR Measurement:** Transfer the solution to a quartz flat cell and immediately measure the EPR spectrum. The formation of the DMPO-OH adduct results in a characteristic four-line spectrum.
- **Data Analysis:** The intensity of the DMPO-OH signal is proportional to the amount of hydroxyl radicals trapped. The percentage of inhibition of the signal intensity by the test compound is calculated to determine the scavenging activity and the IC₅₀ value.[8]

Visualizations

Experimental Workflow for ROS Scavenging Assay

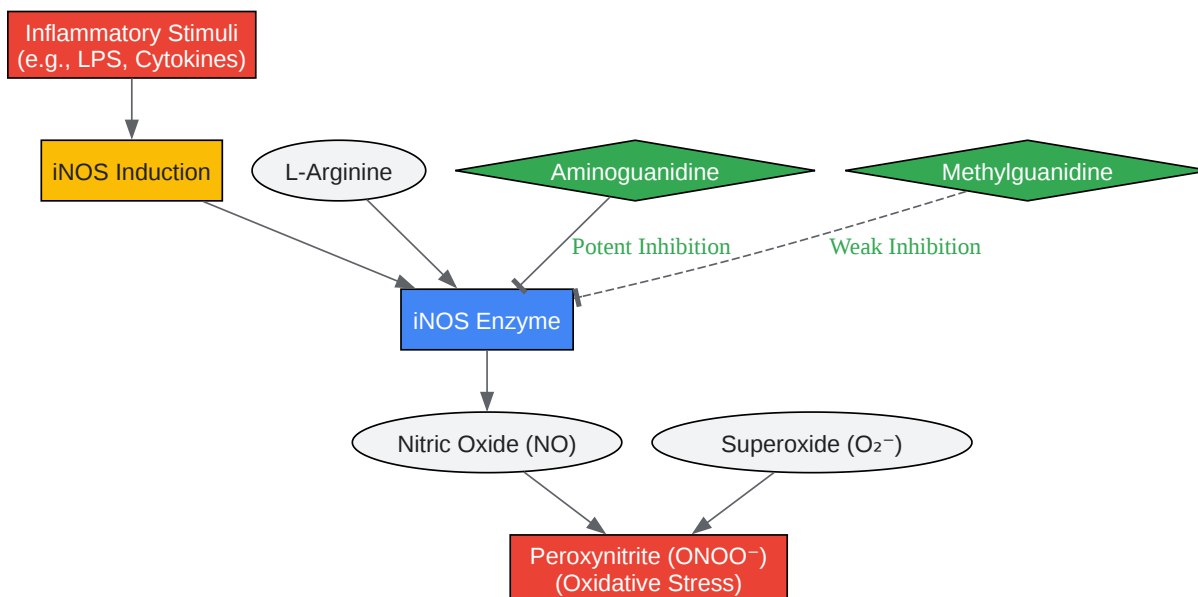
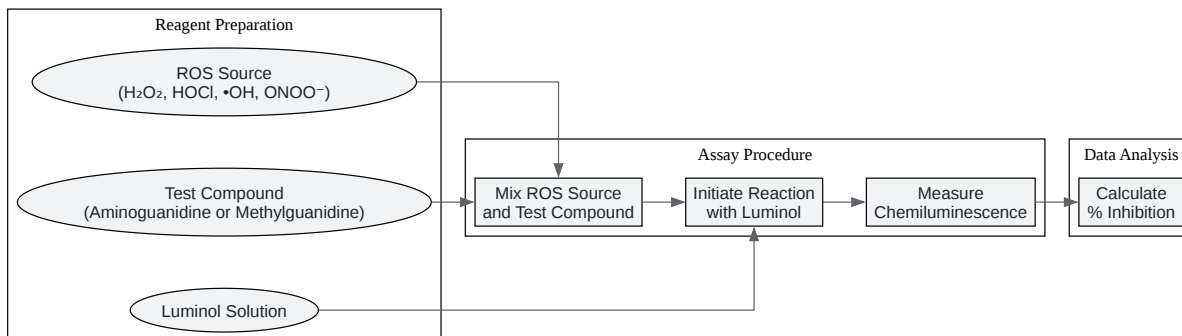

[Click to download full resolution via product page](#)

Need Custom Synthesis?

BenchChem offers custom synthesis for rare earth carbides and specific isotopic labeling.

Email: info@benchchem.com or [Request Quote Online](#).

References

- 1. Comparison of antioxidant activities of aminoguanidine, methylguanidine and guanidine by luminol-enhanced chemiluminescence - PubMed [pubmed.ncbi.nlm.nih.gov]
- 2. Aminoguanidine selectively inhibits inducible nitric oxide synthase - PubMed [pubmed.ncbi.nlm.nih.gov]
- 3. Selective inhibition of the inducible nitric oxide synthase by aminoguanidine - PubMed [pubmed.ncbi.nlm.nih.gov]
- 4. The Use of Aminoguanidine, a Selective iNOS Inhibitor, to Evaluate the Role of Nitric Oxide in the Development of Autoimmune Diabetes - PubMed [pubmed.ncbi.nlm.nih.gov]
- 5. diabetesjournals.org [diabetesjournals.org]
- 6. Effect of aminoguanidine on erythrocyte lipid peroxidation and activities of antioxidant enzymes in experimental diabetes - PubMed [pubmed.ncbi.nlm.nih.gov]
- 7. Attenuation of hyperglycemia and amadori products by aminoguanidine in alloxan-diabetic rabbits occurs via enhancement in antioxidant defenses and control of stress - PMC [pmc.ncbi.nlm.nih.gov]
- 8. researchgate.net [researchgate.net]
- To cite this document: BenchChem. [A Comparative Analysis of the Antioxidant Activities of Aminoguanidine and Methylguanidine]. BenchChem, [2025]. [Online PDF]. Available at: [https://www.benchchem.com/product/b135379#comparing-the-antioxidant-activities-of-aminoguanidine-and-methylguanidine]

Disclaimer & Data Validity:

The information provided in this document is for Research Use Only (RUO) and is strictly not intended for diagnostic or therapeutic procedures. While BenchChem strives to provide

accurate protocols, we make no warranties, express or implied, regarding the fitness of this product for every specific experimental setup.

Technical Support: The protocols provided are for reference purposes. Unsure if this reagent suits your experiment? [[Contact our Ph.D. Support Team for a compatibility check](#)]

Need Industrial/Bulk Grade? [Request Custom Synthesis Quote](#)

BenchChem

Our mission is to be the trusted global source of essential and advanced chemicals, empowering scientists and researchers to drive progress in science and industry.

Contact

Address: 3281 E Guasti Rd

Ontario, CA 91761, United States

Phone: (601) 213-4426

Email: info@benchchem.com