

Comparative Guide: Mass Spectrometry Fragmentation of Ac-D-Trp Peptides

Author: BenchChem Technical Support Team. **Date:** May 2026

Compound of Interest

Compound Name: *Ac-D-Trp(Boc)-OH*

Cat. No.: *B13482480*

[Get Quote](#)

Executive Summary

This guide compares mass spectrometry (MS) methodologies for the analysis of N-acetyl-D-tryptophan (Ac-D-Trp) containing peptides. These peptides are critical in drug development due to the resistance of D-amino acids to enzymatic degradation and the structural stability provided by N-terminal acetylation.

The core analytical challenge is twofold: Sequencing (confirming the amino acid order) and Stereochemical Verification (distinguishing D-Trp from L-Trp). While standard Collision-Induced Dissociation (CID) is sufficient for sequencing, it is often blind to stereochemistry. This guide contrasts standard fragmentation techniques with advanced Ion Mobility Spectrometry (IMS) and Kinetic Method workflows, providing a self-validating protocol for unambiguous characterization.

Part 1: Mechanistic Deep Dive & Fragmentation Pathways

The Role of N-Acetylation and Tryptophan

In standard protonated peptide fragmentation, the mobile proton model dictates cleavage. However, Ac-D-Trp peptides exhibit unique behaviors:

- **N-Acetyl Effect:** Acetylation removes the basic N-terminal amine, sequestering the proton to the peptide backbone or the Tryptophan indole ring. This stabilizes the b1 ion (Ac-Trp), which is often unstable or absent in non-acetylated peptides.
- **Indole Side Chain:** The Tryptophan side chain is highly labile. High-energy collisions (HCD) often strip the side chain, yielding the immonium ion (m/z 159) and the indole radical cation (m/z 130).

Fragmentation Modes: CID vs. HCD vs. ETD

Feature	CID (Trap-Type)	HCD (Beam-Type)	ETD (Electron Transfer)
Primary Ion Series	b/y ions. Dominant backbone cleavage.	b/y ions + Immonium. High internal energy access.	c/z ions. Preserves labile PTMs.
Ac-Trp Specifics	Good for sequence. ^[1] 1/3 Rule in traps may cut off low mass reporters (m/z 130/159).	Best for diagnostic ions. Clearly shows m/z 159 (Trp immonium) and Ac-b1 ions.	Less efficient for small, singly charged Ac-Trp peptides.
Stereo-Sensitivity	Low. D/L isomers produce identical mass fragments.	Low. Higher energy does not resolve chirality.	Low/Medium. H-bonding differences may alter c/z ratios slightly.

Visualization: Ac-Trp Fragmentation Pathway

The following diagram illustrates the competing fragmentation pathways for a protonated Ac-D-Trp peptide.

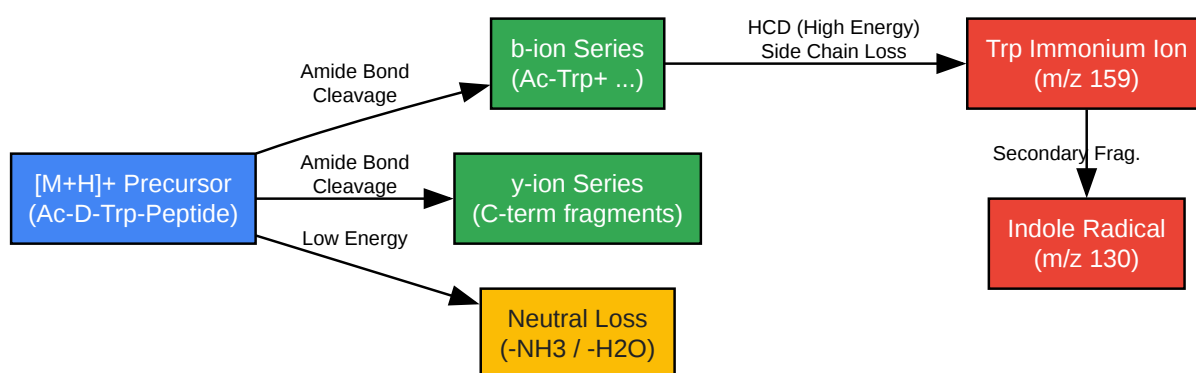

[Click to download full resolution via product page](#)

Caption: Fragmentation cascade of Ac-D-Trp peptides. HCD is required to access diagnostic side-chain ions (red).

Part 2: Stereochemical Differentiation (D vs. L)

Standard MS/MS cannot easily distinguish Ac-D-Trp from Ac-L-Trp because they are enantiomers with identical masses and similar fragmentation energies. To validate the "D" configuration, you must use Ion Mobility or Chiral Complexation.

Comparative Analysis of Differentiation Methods

Metric	Method A: Ion Mobility (IMS)	Method B: The Kinetic Method (Trimer)
Principle	Separates ions based on Collision Cross Section (CCS) (gas-phase shape). D-isomers often fold more compactly than L-isomers.	Forms a trimeric complex [M + Ref + Cu(II)]. Dissociation ratios differ based on chiral recognition energy.
Equipment	Requires IMS-enabled MS (e.g., TIMS, TWIMS, FAIMS).	Requires standard ESI-MS/MS (Trap or Q-TOF).
Throughput	High. Online LC-IMS-MS allows separation in milliseconds.	Low. Requires infusion of specific metal/reference mixtures.
Sensitivity	High.	Medium (signal split into complex).
Verdict	Gold Standard for modern workflows.	Best Alternative for standard labs without IMS hardware.

Part 3: Experimental Protocols

Protocol A: High-Confidence Sequencing (HCD)

Use this to confirm the peptide sequence and acetylation status.

- Sample Prep: Dissolve Ac-D-Trp peptide to 1 μ M in 50:50 Water:Acetonitrile + 0.1% Formic Acid.
- Infusion: Direct infusion at 5 μ L/min into Orbitrap or Q-TOF.
- MS1 Acquisition: Verify precursor m/z. Check for Na⁺ adducts (+22 Da) which are common with acetylated peptides.
- MS2 Parameters (HCD):
 - Isolation Width: 1.5 Da.

- NCE (Normalized Collision Energy): Stepped 25, 30, 35%.
- Critical Check: Look for m/z 159.09 (Trp Immonium). Its presence confirms Trp. Look for the b1 ion (Ac-Trp mass = 243.11 Da).
- Data Analysis: Use de novo sequencing. Note that standard search engines may default to L-amino acids; manual verification of the "Ac-" delta mass (+42.01 Da) at the N-terminus is required.

Protocol B: D/L Isomer Differentiation (IMS-MS)

Use this to prove you have the D-isomer and not the L-impurity.

- Setup: Calibrate the IMS cell (TIMS/TWIMS) using polyalanine or commercial CCS standards.
- Standards: You must run a synthetic Ac-L-Trp standard and your Ac-D-Trp sample.
- Acquisition:
 - Soft ionization (prevent in-source fragmentation).
 - Ramp IMS voltage/wave height to cover the expected mobility range.
- Analysis: Extract the mobilogram for the precursor m/z .
 - Result: D-peptides typically exhibit a smaller CCS (shorter drift time) due to different H-bonding networks forming more compact gas-phase structures compared to the all-L helices.
 - Calculation: Calculate Resolution ()
(). If
between sample and L-standard, the assignment is unambiguous.

Protocol C: The Kinetic Method (For Standard MS)

Use this if you lack IMS hardware.

- Reagent: Prepare 1 mM Cu(II) acetate and 1 mM Reference Ligand (e.g., L-Proline or N-Boc-L-Pro).
- Mixing: Mix Analyte (A), Reference (Ref), and Cu(II) in a 1:1:1 ratio.
- MS Analysis: Select the trimeric cluster ion $[A + \text{Ref} + \text{Cu} - \text{H}]^+$ as the precursor.
- Fragmentation: Apply low collision energy (CID) to dissociate the cluster.
- Ratio Calculation: Measure the intensity of fragments corresponding to the loss of the Analyte vs. the Reference.
 - .
 - The

value will differ significantly between Ac-D-Trp and Ac-L-Trp complexes due to steric hindrance in the copper coordination sphere.

Part 4: Logical Workflow Visualization

The following diagram outlines the decision tree for analyzing these peptides, ensuring both sequence identity and stereochemical purity.

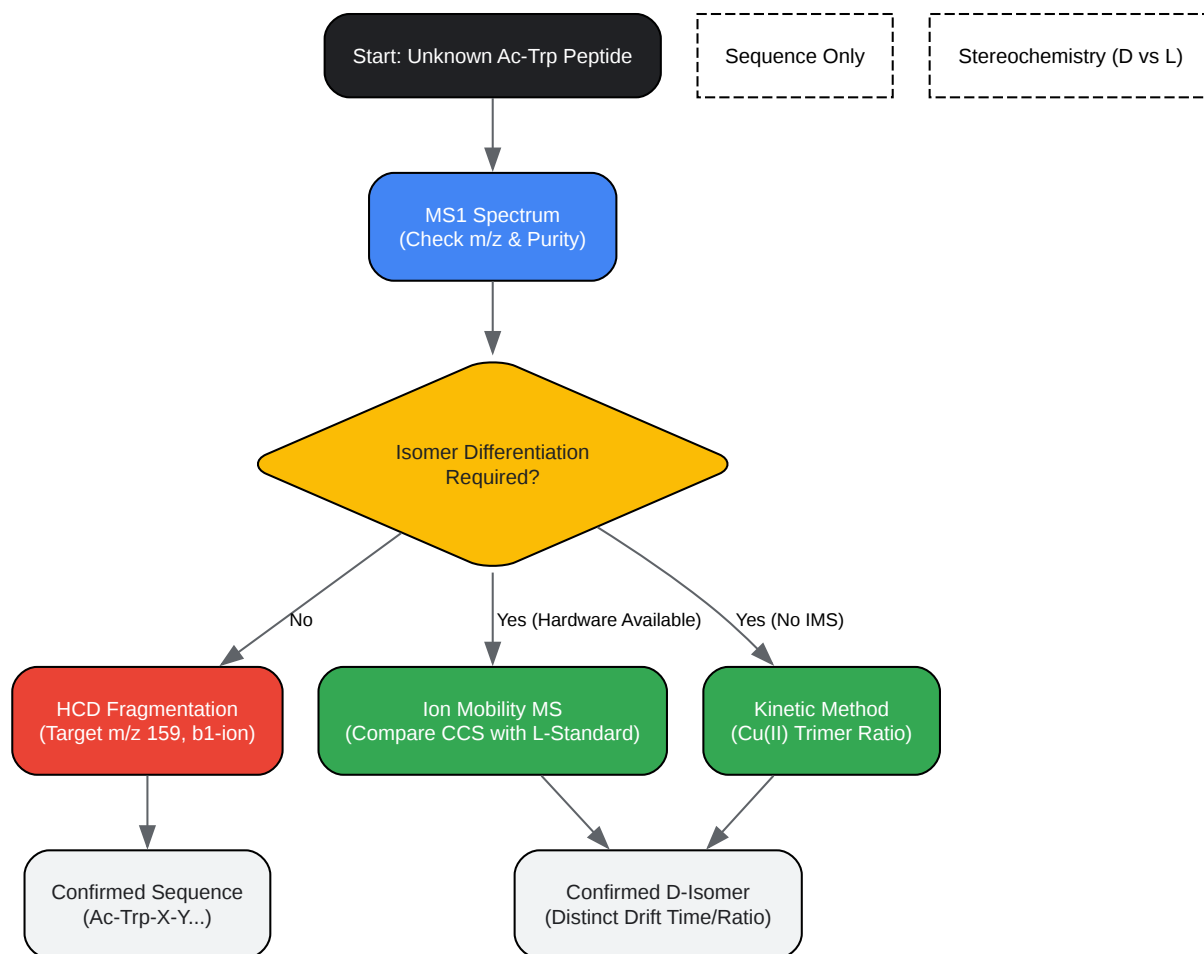

[Click to download full resolution via product page](#)

Caption: Decision matrix for Ac-D-Trp analysis. IMS is preferred for stereochemistry; HCD is preferred for sequencing.

References

- Differentiation of D- and L-peptides by Ion Mobility: Berthias, F., et al. (2021).[2][3]
Differential Ion Mobility Separations of d/l Peptide Epimers. Analytical Chemistry. [\[Link\]](#)

- Tryptophan Fragmentation Mechanisms: Asakawa, D., et al. (2021). Fragmentation study of tryptophan-derived metabolites induced by electrospray ionization mass spectrometry. The Analyst. [[Link](#)]
- Chiral Recognition via Kinetic Method: Tao, W. A., & Cooks, R. G. (2003). Chiral analysis by mass spectrometry. Analytical Chemistry. [[Link](#)]
- Ac-Trp Peptide Analysis Context: Serafin, S. V., et al. (2005).^[4] Mass spectrometric differentiation of linear peptides composed of L-amino acids from isomers containing one D-amino acid residue. Analytical Chemistry. [[Link](#)]

Need Custom Synthesis?

BenchChem offers custom synthesis for rare earth carbides and specific isotopic labeling.

Email: info@benchchem.com or [Request Quote Online](#).

Sources

- [1. researchgate.net \[researchgate.net\]](#)
- [2. Differential Ion Mobility Separations of d/l Peptide Epimers - PubMed \[pubmed.ncbi.nlm.nih.gov\]](#)
- [3. Fast and Effective Ion Mobility - Mass Spectrometry Separation of D-Amino Acid Containing Peptides - PMC \[pmc.ncbi.nlm.nih.gov\]](#)
- [4. Mass spectrometric differentiation of linear peptides composed of L-amino acids from isomers containing one D-amino acid residue - PubMed \[pubmed.ncbi.nlm.nih.gov\]](#)
- To cite this document: BenchChem. [Comparative Guide: Mass Spectrometry Fragmentation of Ac-D-Trp Peptides]. BenchChem, [2026]. [Online PDF]. Available at: [<https://www.benchchem.com/product/b13482480/docs#comparative-guide-mass-spectrometry-fragmentation-of-ac-d-trp-peptides>]

Disclaimer & Data Validity:

The information provided in this document is for Research Use Only (RUO) and is strictly not intended for diagnostic or therapeutic procedures. While BenchChem strives to provide

accurate protocols, we make no warranties, express or implied, regarding the fitness of this product for every specific experimental setup.

Technical Support: The protocols provided are for reference purposes. Unsure if this reagent suits your experiment?

Need Industrial/Bulk Grade? [Request Custom Synthesis Quote](#)

BenchChem

Our mission is to be the trusted global source of essential and advanced chemicals, empowering scientists and researchers to drive progress in science and industry.

Contact

Address: 3281 E Guasti Rd

Ontario, CA 91761, United States

Phone: (601) 213-4426

Email: info@benchchem.com

[Contact our Ph.D. Support Team for a compatibility check](#)