

# Technical Support Center: Synthesis of Thiophene-Substituted Pyrazoles

**Author:** BenchChem Technical Support Team. **Date:** May 2026

## Compound of Interest

Compound Name: 2-(4-Methylphenyl)-5-thiophen-2-ylpyrazole-3-carboxylic acid

CAS No.: 618382-78-8

Cat. No.: B1347489

[Get Quote](#)

Welcome to the technical support center for the synthesis of thiophene-substituted pyrazoles. This resource is designed for researchers, scientists, and drug development professionals to provide in-depth troubleshooting guides and frequently asked questions (FAQs). The following content addresses specific issues you may encounter during your experiments, with a focus on mechanistic understanding and practical solutions.

## Troubleshooting Guide

This section is dedicated to resolving common and unexpected issues that can arise during the synthesis of thiophene-substituted pyrazoles. Each question is addressed with an explanation of the underlying chemistry and actionable steps to rectify the problem.

**Q1: My reaction is producing a mixture of regioisomers that are difficult to separate. How can I improve the regioselectivity?**

A1: The formation of regioisomeric mixtures is a well-known challenge in pyrazole synthesis, particularly when using unsymmetrical 1,3-dicarbonyl compounds or their equivalents.[1][2][3] The regioselectivity is primarily governed by the relative electrophilicity of the two carbonyl carbons and the steric hindrance around them.

Underlying Cause: In the classical Knorr synthesis, the initial nucleophilic attack of the hydrazine can occur at either of the two carbonyl carbons of the 1,3-diketone. The subsequent cyclization and dehydration lead to the formation of two different pyrazole regioisomers. The reaction conditions, especially pH and solvent, play a crucial role in determining the preferred pathway.[1]

Troubleshooting Strategies:

- **pH Control:** The pH of the reaction medium can significantly influence the site of the initial hydrazine attack. Acidic conditions can protonate the carbonyl oxygen, enhancing the electrophilicity of the carbonyl carbon. The extent of this enhancement can differ between the two carbonyl groups based on the electronic effects of their substituents. Experiment with buffered solutions or the addition of a catalytic amount of a protic acid like acetic acid to find the optimal pH for the desired isomer.
- **Solvent Effects:** The polarity and hydrogen-bonding ability of the solvent can affect the stability of the intermediates and transition states, thereby influencing the regioselectivity. For instance, using fluorinated alcohols like 2,2,2-trifluoroethanol (TFE) has been shown to dramatically increase regioselectivity in some pyrazole syntheses.[3]
- **Steric Hindrance:** If one of the carbonyl groups is significantly more sterically hindered than the other, the hydrazine will preferentially attack the less hindered carbonyl. You can leverage this by choosing starting materials with bulky protecting groups that can be removed later.
- **Stepwise Synthesis:** A more controlled approach is to synthesize the pyrazole ring in a stepwise manner. For example, you can first form a hydrazone at one carbonyl group under controlled conditions and then induce cyclization.

**Q2: I am observing an unexpected side product with a mass corresponding to the addition of my solvent**

## (ethanol). What is happening?

A2: This is likely an example of a solvent-mediated side reaction, which can occur under specific conditions, especially with reactive intermediates.

**Underlying Cause:** In a multistep synthesis starting from thiophene-containing chalcones, an unusual side reaction has been reported where a bromine atom beta to a carbonyl group is replaced by an ethoxy group from the ethanol solvent.<sup>[4]</sup> This suggests the formation of a reactive intermediate, such as a carbocation or a highly polarized carbon-bromine bond, which is susceptible to nucleophilic attack by the solvent.

**Troubleshooting Strategies:**

- **Solvent Choice:** The most straightforward solution is to switch to a non-nucleophilic solvent. Aprotic solvents like toluene, dioxane, or acetonitrile are excellent alternatives that will not participate in the reaction.
- **Temperature Control:** Lowering the reaction temperature can often suppress side reactions by reducing the energy available for alternative reaction pathways.
- **Reaction Time:** Monitor the reaction closely by TLC or LC-MS. If the desired product forms faster than the side product, you can quench the reaction before the side product becomes significant.

## Q3: My yield is consistently low, even though my starting materials are consumed. What are the likely causes and how can I improve it?

A3: Low yields in the absence of remaining starting materials often point towards the formation of soluble, uncharacterized byproducts or decomposition of the product under the reaction conditions.<sup>[5]</sup>

**Underlying Cause:** Several factors can contribute to low yields in pyrazole synthesis:

- **Side Reactions:** As discussed, the formation of regioisomers and other unexpected products can divert material from your desired product.<sup>[1][4]</sup>

- **Decomposition:** The thiophene or pyrazole ring can be sensitive to harsh reaction conditions, such as strong acids or high temperatures, leading to decomposition.
- **Complex Reaction Pathways:** Recent studies have shown that even well-established reactions like the Knorr synthesis can have unexpectedly complex pathways, involving intermediates from the di-addition of hydrazine.[1] These intermediates may not efficiently convert to the final product.

#### Troubleshooting Strategies:

- **Optimize Reaction Conditions:**
  - **Temperature:** While heating is often necessary, excessive heat can lead to decomposition. Try running the reaction at a lower temperature for a longer period.
  - **Catalyst:** The choice and concentration of the catalyst are critical. For acid-catalyzed reactions, a milder acid like acetic acid might be preferable to a strong mineral acid. In some cases, Lewis acids or nano-ZnO have been shown to improve yields.[5]
- **Microwave-Assisted Synthesis:** Microwave irradiation can often improve yields and significantly reduce reaction times by providing rapid and uniform heating.[5]
- **Purification Strategy:** Ensure that your purification method is not leading to product loss. Thiophene-substituted pyrazoles can sometimes be volatile or adsorb strongly to silica gel. Consider alternative purification methods like recrystallization or preparative HPLC.

## Frequently Asked Questions (FAQs)

### Q1: What are the most common synthetic routes to thiophene-substituted pyrazoles?

A1: The most prevalent methods include:

- **Cyclocondensation of Thiophene-Containing 1,3-Diketones or Chalcones with Hydrazines:** This is a classic and versatile method.[6]
- **Vilsmeier-Haack Reaction:** This is used to synthesize pyrazole-4-carbaldehydes, which are key intermediates for further functionalization with thiophene moieties.[6][7]

- Multistep Synthesis from Thiophene Analogues: This can involve steps like bromination and subsequent ring closure to form the pyrazole ring.[4]

## Q2: How can I confirm the regiochemistry of my synthesized pyrazole?

A2: The most definitive method for structure elucidation is single-crystal X-ray crystallography. However, this is not always feasible. Spectroscopic methods are more commonly used:

- Nuclear Magnetic Resonance (NMR) Spectroscopy: 2D NMR techniques like HMBC (Heteronuclear Multiple Bond Correlation) and NOESY (Nuclear Overhauser Effect Spectroscopy) are powerful tools. HMBC can show correlations between protons and carbons that are 2-3 bonds away, helping to establish the connectivity of the molecule. NOESY can show through-space correlations between protons that are close to each other, which can help to distinguish between regioisomers.
- Mass Spectrometry (MS): While MS will give you the molecular weight of the isomers (which is the same), fragmentation patterns in MS/MS experiments can sometimes provide clues to the structure.

## Q3: What are some common challenges in the purification of thiophene-substituted pyrazoles?

A3: Common purification challenges include:

- Separation of Regioisomers: As discussed, these can be difficult to separate by standard column chromatography due to their similar polarities. Preparative HPLC or supercritical fluid chromatography (SFC) may be necessary.
- Tautomerism: NH-pyrazoles can exist in tautomeric forms, which can sometimes lead to broadened peaks in NMR spectra and streaking on TLC plates.[4]
- Product Volatility: Some smaller thiophene-substituted pyrazoles can be volatile, leading to loss of product during solvent removal under high vacuum.

## Data Presentation

**Table 1: Common Side Reactions and Troubleshooting**

Side Reaction/Issue	Potential Cause	Proposed Solution
Formation of Regioisomers	Use of unsymmetrical 1,3-dicarbonyl precursors.	Optimize pH and solvent; consider steric effects or a stepwise synthesis.[1][3]
Solvent Adduct Formation	Reactive intermediates reacting with nucleophilic solvents (e.g., ethanol).	Use a non-nucleophilic solvent like toluene or dioxane.[4]
Low Yield	Incomplete reaction, product decomposition, or complex side reactions.	Optimize temperature and catalyst; consider microwave-assisted synthesis.[5]
Di-addition of Hydrazine	A newly identified complex reaction pathway in the Knorr synthesis.	Carefully control the stoichiometry of the reactants. [1]

## Experimental Protocols

### General Protocol for the Synthesis of a Thiophene-Substituted Pyrazole from a Thiophene-Chalcone

This protocol is a general guideline and may require optimization for specific substrates.

- Chalcone Synthesis:
  - To a stirred solution of 2-acetylthiophene (1.0 eq) and a substituted benzaldehyde (1.0 eq) in ethanol, add a catalytic amount of a base (e.g., 10% NaOH solution).
  - Stir the reaction mixture at room temperature until the reaction is complete (monitor by TLC).
  - Pour the reaction mixture into cold water and collect the precipitated chalcone by filtration. Wash with water and recrystallize from a suitable solvent (e.g., ethanol).
- Pyrazole Formation:

- To a solution of the thiophene-chalcone (1.0 eq) in a suitable solvent (e.g., acetic acid or ethanol), add hydrazine hydrate or a substituted hydrazine (1.1 eq).
- Reflux the reaction mixture for several hours until the starting material is consumed (monitor by TLC).
- Cool the reaction mixture to room temperature and pour it into ice-water.
- Collect the solid product by filtration, wash with water, and dry.
- Purify the crude product by column chromatography on silica gel or by recrystallization.

Critical Step: The choice of solvent and acid/base catalyst in the pyrazole formation step is crucial for controlling regioselectivity and minimizing side reactions.

## Mandatory Visualization

### Diagram 1: General Reaction Scheme and Potential Side Reactions

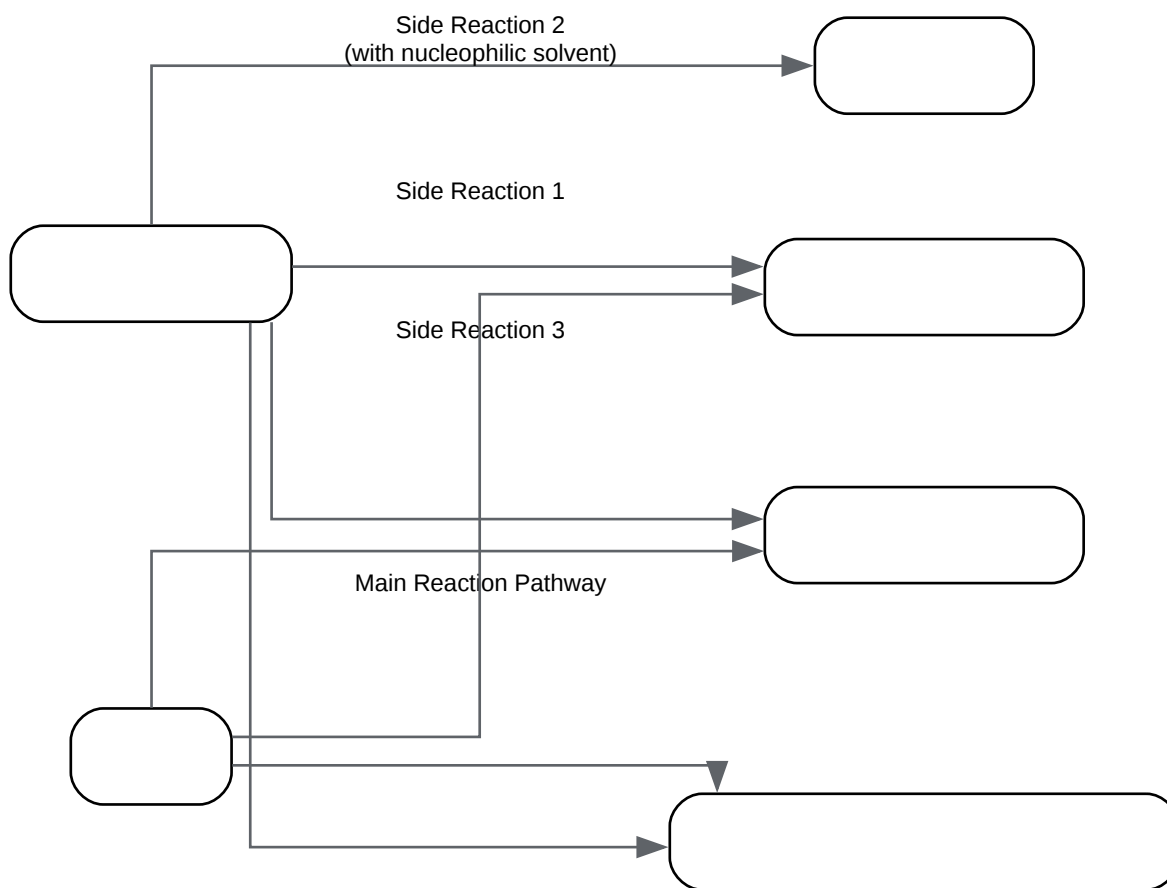

[Click to download full resolution via product page](#)

Caption: Reaction pathways in thiophene-substituted pyrazole synthesis.

## References

- Discovery of unexpectedly complex reaction pathways for the Knorr pyrazole synthesis via transient flow. RSC Publishing. [\[Link\]](#)
- Roman, G. (2015). Multistep synthesis of pyrazoles from thiophene-containing chalcone analogues. ResearchGate. [\[Link\]](#)
- Sala, R., et al. (2020). Synthesis and Pharmacological Activities of Pyrazole Derivatives: A Review. MDPI. [\[Link\]](#)
- Fustero, S., et al. (2008). Improved Regioselectivity in Pyrazole Formation through the Use of Fluorinated Alcohols as Solvents: Synthesis and Biological Activity of Fluorinated Tebufenpyrad Analogs. The Journal of Organic Chemistry. [\[Link\]](#)

- Synthesis and Characterization of Pyrazole Heterocyclic Derivatives via Vilsmeier-Haack-Reaction and its Schiff's Bases. STM Journals. [\[Link\]](#)
- Pyrazole synthesis. Organic Chemistry Portal. [\[Link\]](#)
- Recent Advances in the Synthesis of Pyrazole Derivatives: A Review. MDPI. [\[Link\]](#)
- Regioselective synthesis of functionalized pyrazole-chalcones via a base mediated reaction of diazo compounds with pyrylium salts. Organic & Biomolecular Chemistry. [\[Link\]](#)
- VILSMEIER-HAACK SYNTHESIS OF NEW STEROIDAL PYRAZOLES. Bibliomed. [\[Link\]](#)
- Unravelling the synthetic and therapeutic aspects of five, six and fused heterocycles using Vilsmeier–Haack reagent. National Institutes of Health. [\[Link\]](#)
- (PDF) Synthesis and Characterization of Pyrazole Heterocyclic Derivatives via Vilsmeier-Haack-Reaction and Its Schiff's Bases. ResearchGate. [\[Link\]](#)
- Chalcone Derived Pyrazole Synthesis via One-pot and Two-pot Strategies. ResearchGate. [\[Link\]](#)
- REVIEW ARTICLE ON VILSMEIER-HAACK REACTION. ResearchGate. [\[Link\]](#)
- A Review of the Recent Development in the Synthesis and Biological Evaluations of Pyrazole Derivatives. National Institutes of Health. [\[Link\]](#)
- Mechanistic pathway for synthesis of pyrazole-chalcone derivatives. ResearchGate. [\[Link\]](#)
- Aly, A. A., et al. (2021). Substituted Pyrazoles and Their Heteroannulated Analogs—Recent Syntheses and Biological Activities. MDPI. [\[Link\]](#)
- Synthesis, characterization, biological activities, and computational studies of pyrazolyl–thiazole derivatives of thiophene. National Institutes of Health. [\[Link\]](#)
- Naturally occurring thiophenes: isolation, purification, structural elucidation, and evaluation of bioactivities. CAB Direct. [\[Link\]](#)

- Design And Development of Pyrazole-Substituted Chalcones: A Synthetic Perspective. IJIRT. [\[Link\]](#)
- Short Review on the Synthesis of Thiophene, Pyrazole, and Thiazole Derivatives. Sci-Hub. [\[Link\]](#)
- synthesis and biological screening of some new thiophene and pyrazole containing styrylchromones. Connect Journals. [\[Link\]](#)

### Need Custom Synthesis?

BenchChem offers custom synthesis for rare earth carbides and specific isotopic labeling.

Email: [info@benchchem.com](mailto:info@benchchem.com) or [Request Quote Online](#).

## Sources

- [1. Discovery of unexpectedly complex reaction pathways for the Knorr pyrazole synthesis via transient flow - Reaction Chemistry & Engineering \(RSC Publishing\)](#)  
[DOI:10.1039/D2RE00271J](https://doi.org/10.1039/D2RE00271J) [[pubs.rsc.org](https://pubs.rsc.org)]
- [2. mdpi.com](#) [[mdpi.com](https://mdpi.com)]
- [3. Synthesis and Pharmacological Activities of Pyrazole Derivatives: A Review - PMC](#)  
[[pmc.ncbi.nlm.nih.gov](https://pubmed.ncbi.nlm.nih.gov)]
- [4. researchgate.net](#) [[researchgate.net](https://researchgate.net)]
- [5. pdf.benchchem.com](#) [[pdf.benchchem.com](https://pdf.benchchem.com)]
- [6. mdpi.com](#) [[mdpi.com](https://mdpi.com)]
- [7. Synthesis, characterization, biological activities, and computational studies of pyrazolyl–thiazole derivatives of thiophene - PMC](#) [[pmc.ncbi.nlm.nih.gov](https://pubmed.ncbi.nlm.nih.gov)]
- To cite this document: BenchChem. [Technical Support Center: Synthesis of Thiophene-Substituted Pyrazoles]. BenchChem, [2026]. [Online PDF]. Available at: [\[https://www.benchchem.com/product/b1347489/docs#technical-support-center-synthesis-of-thiophene-substituted-pyrazoles\]](https://www.benchchem.com/product/b1347489/docs#technical-support-center-synthesis-of-thiophene-substituted-pyrazoles)

---

### Disclaimer & Data Validity:

The information provided in this document is for Research Use Only (RUO) and is strictly not intended for diagnostic or therapeutic procedures. While BenchChem strives to provide accurate protocols, we make no warranties, express or implied, regarding the fitness of this product for every specific experimental setup.

**Technical Support:** The protocols provided are for reference purposes. Unsure if this reagent suits your experiment?

**Need Industrial/Bulk Grade?** [Request Custom Synthesis Quote](#)

## BenchChem

Our mission is to be the trusted global source of essential and advanced chemicals, empowering scientists and researchers to drive progress in science and industry.

### Contact

Address: 3281 E Guasti Rd  
Ontario, CA 91761, United States  
Phone: (601) 213-4426  
Email: [info@benchchem.com](mailto:info@benchchem.com)

[Contact our Ph.D. Support Team for a compatibility check](#)