

HPLC method development for purity analysis of fluorinated pyridines

Author: BenchChem Technical Support Team. **Date:** April 2026

Compound of Interest

Compound Name: *2-Bromo-6-(1,1,2-trifluoroethyl)pyridine*

Cat. No.: *B13465828*

[Get Quote](#)

An In-Depth Guide to HPLC Method Development for Purity Analysis of Fluorinated Pyridines

Authored by: A Senior Application Scientist

In the landscape of pharmaceutical development, fluorinated pyridines represent a class of compounds with immense therapeutic potential. Their unique electronic properties, conferred by the electronegative fluorine atom and the basic pyridine ring, also present distinct challenges for analytical chemists tasked with purity assessment. Standard High-Performance Liquid Chromatography (HPLC) methods often fall short, plagued by issues like poor peak shape, insufficient retention, and inadequate resolution of closely related impurities.

This guide provides a comprehensive, field-proven comparison of strategies for developing robust and reliable HPLC methods for the purity analysis of fluorinated pyridines. We will move beyond generic protocols to explore the fundamental chromatographic principles at play, enabling you to make informed decisions and troubleshoot effectively. Our focus is on building self-validating methods that adhere to the highest standards of scientific integrity and meet stringent regulatory expectations.

The Core Challenge: Understanding Analyte-Stationary Phase Interactions

The primary difficulty in analyzing fluorinated pyridines stems from their dual nature. The pyridine nitrogen is basic (pKa typically around 5-6), making it prone to protonation and strong, undesirable interactions with residual silanol groups on traditional silica-based stationary phases.[1][2] This leads to significant peak tailing, which compromises both resolution and accurate quantification. Furthermore, depending on the degree and position of fluorination, these molecules can range from moderately polar to highly hydrophilic, challenging retention on conventional C18 columns.[3]

A successful method must therefore accomplish two things: mitigate the silanol interactions and provide an alternative, dominant retention mechanism.

Strategic Column Selection: A Comparative Analysis

The choice of stationary phase is the most critical decision in the method development process. While the C18 column is the workhorse of reversed-phase chromatography, it is often not the optimal choice for this class of compounds.

dot

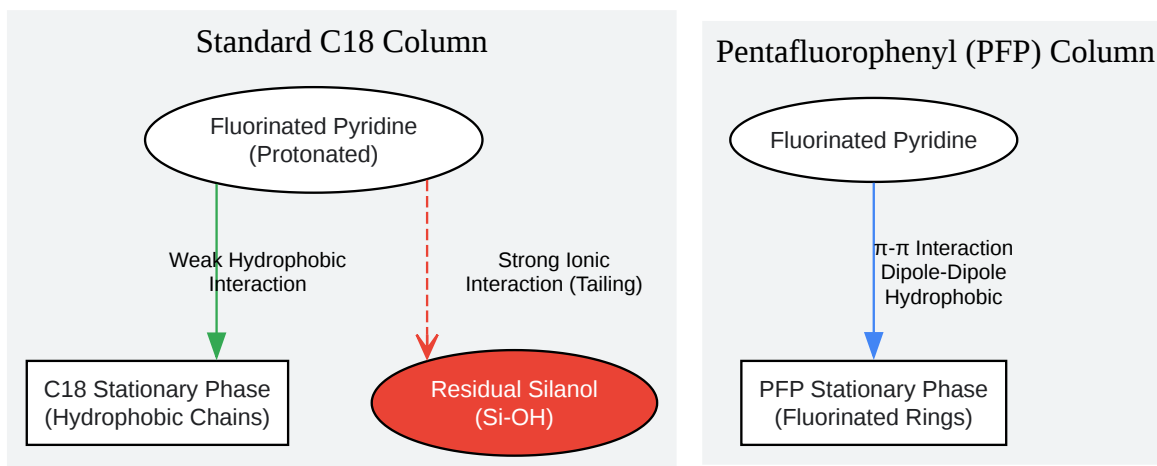

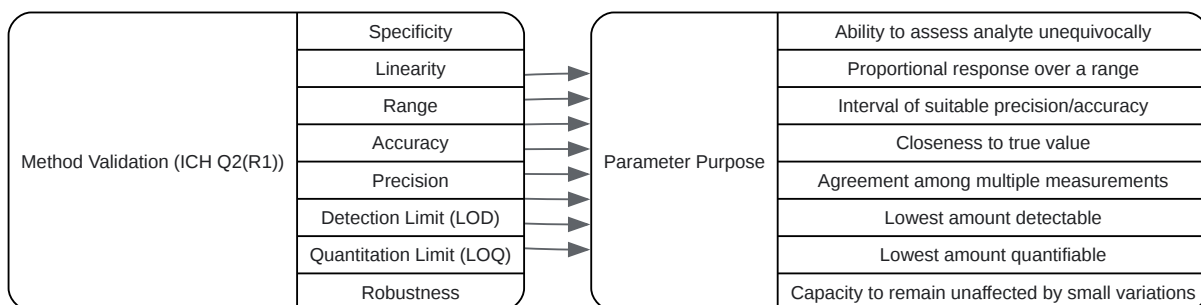
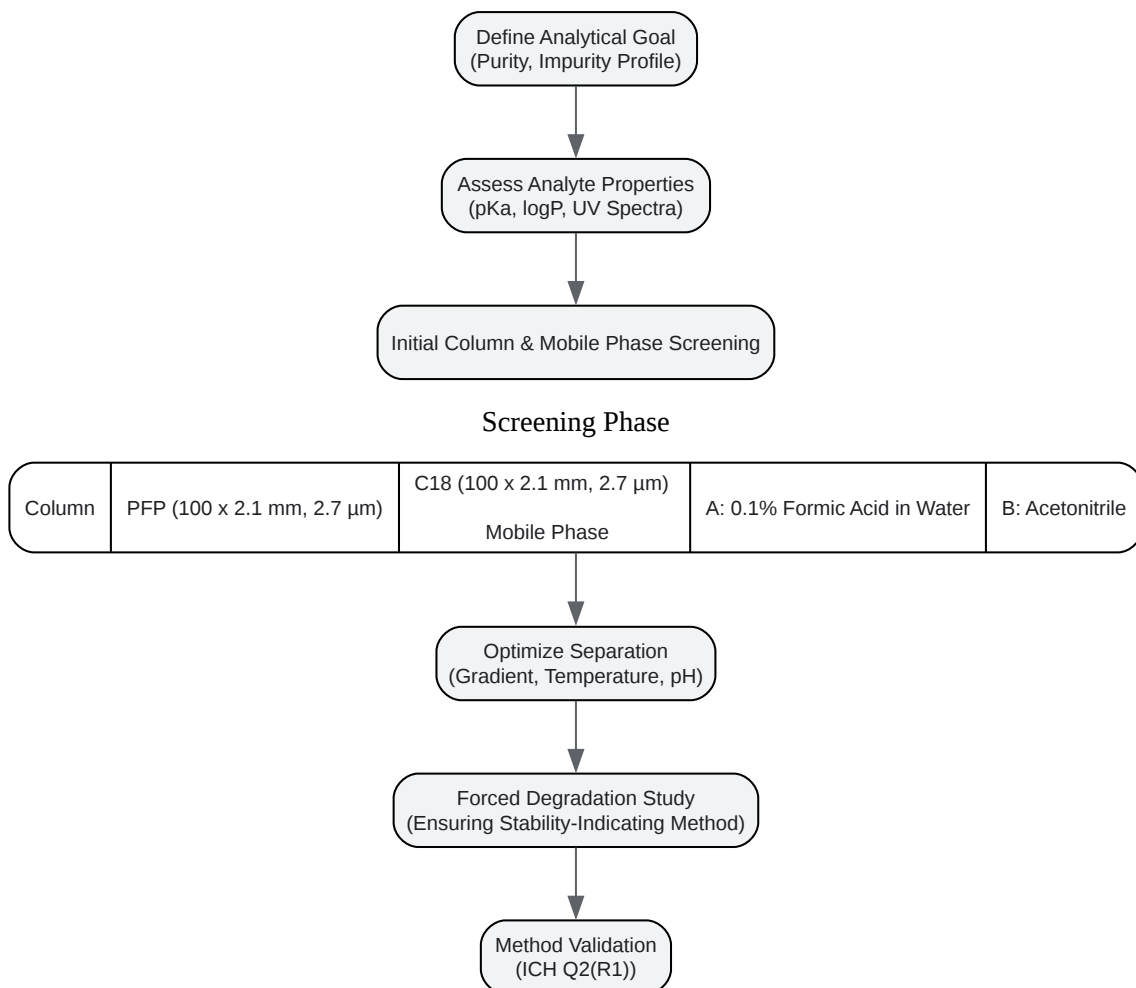

[Click to download full resolution via product page](#)

Need Custom Synthesis?

BenchChem offers custom synthesis for rare earth carbides and specific isotopic labeling.

Email: info@benchchem.com or [Request Quote Online](#).

Sources

- [1. pdf.benchchem.com \[pdf.benchchem.com\]](https://pdf.benchchem.com)
- [2. Method for pyridine amine derivative - Chromatography Forum \[chromforum.org\]](https://chromforum.org)
- [3. pdf.benchchem.com \[pdf.benchchem.com\]](https://pdf.benchchem.com)
- To cite this document: BenchChem. [HPLC method development for purity analysis of fluorinated pyridines]. BenchChem, [2026]. [Online PDF]. Available at: [\[https://www.benchchem.com/product/b13465828/docs#hplc-method-development-for-purity-analysis-of-fluorinated-pyridines\]](https://www.benchchem.com/product/b13465828/docs#hplc-method-development-for-purity-analysis-of-fluorinated-pyridines)

Disclaimer & Data Validity:

The information provided in this document is for Research Use Only (RUO) and is strictly not intended for diagnostic or therapeutic procedures. While BenchChem strives to provide accurate protocols, we make no warranties, express or implied, regarding the fitness of this product for every specific experimental setup.

Technical Support: The protocols provided are for reference purposes. Unsure if this reagent suits your experiment?

Need Industrial/Bulk Grade? [Request Custom Synthesis Quote](#)

BenchChem

Our mission is to be the trusted global source of essential and advanced chemicals, empowering scientists and researchers to drive progress in science and industry.

Contact

Address: 3281 E Guasti Rd

Ontario, CA 91761, United States

Phone: (601) 213-4426

Email: info@benchchem.com

[Contact our Ph.D. Support Team for a compatibility check](#)