

# Application Note: Precision Deprotection of TMS Groups in Quinazoline Synthesis

**Author:** BenchChem Technical Support Team. **Date:** April 2026

## Compound of Interest

Compound Name: 7-[2-(Trimethylsilyl)ethynyl]quinazoline  
Cat. No.: B13463125

[Get Quote](#)

## Abstract

The removal of trimethylsilyl (TMS) protecting groups is a pivotal step in the synthesis of quinazoline-based pharmacophores, particularly in the development of EGFR inhibitors like Erlotinib and Gefitinib. While Tetra-n-butylammonium fluoride (TBAF) is the industry-standard reagent for this transformation, its application in electron-deficient heteroaromatic systems requires strict control to prevent nucleophilic fluorination side reactions and to manage the notorious difficulty of removing tetrabutylammonium salts. This guide provides an optimized, mechanism-driven protocol for TBAF-mediated desilylation, featuring a self-validating workup strategy designed to ensure high purity for downstream biological assays.

## Strategic Context & Mechanism

### The Role of TMS in Quinazoline Chemistry

In medicinal chemistry, the quinazoline core is frequently functionalized at the C4 position via Sonogashira coupling. The TMS group serves two critical roles here:

- **Protection:** It masks the terminal alkyne proton, preventing homocoupling (Glaser coupling) during palladium-catalyzed cross-coupling.
- **Solubility:** It enhances the lipophilicity of polar quinazoline intermediates, facilitating purification.

The subsequent removal of the TMS group regenerates the terminal alkyne, a "chemical handle" essential for "Click" chemistry (triazole formation) or further derivatization.

## Mechanistic Insight: The Fluoride Driver

TBAF functions based on the high bond dissociation energy of the Si–F bond (approx. 135 kcal/mol) compared to the Si–C bond.

The Pathway:

- **Nucleophilic Attack:** The fluoride ion (  $F^-$  ) attacks the silicon atom of the TMS group.<sup>[1]</sup>
- **Hypervalent Intermediate:** A transient pentacoordinate silicate anion is formed.
- **Cleavage:** The Si–C bond cleaves, releasing the organic carbanion (or alkoxide) and the volatile byproduct  $SiF_4$ .
- **Protonation:** The carbanion is protonated by adventitious water (always present in TBAF/THF) or an added proton source to yield the final product.

Graphviz Diagram 1: Mechanistic Pathway

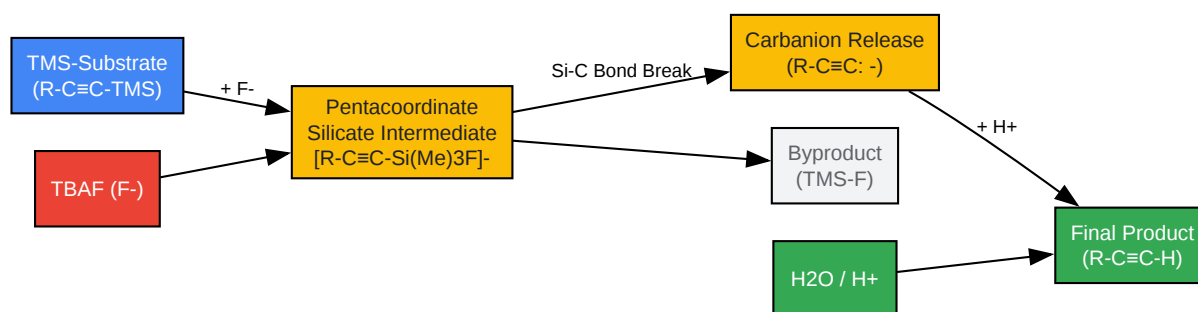

[Click to download full resolution via product page](#)

Caption: Kinetic pathway of fluoride-mediated desilylation showing the critical protonation step.

## Critical Parameters & Risks

### The "TBAF Blob" Phenomenon

The most common failure mode is not the reaction itself, but the workup. Tetrabutylammonium salts behave as phase-transfer catalysts and surfactants.

- Risk: They form emulsions during aqueous extraction.
- Risk: They "streak" on silica gel columns, co-eluting with polar quinazolines and suppressing ionization in LC-MS analysis.

### Chemoselectivity in Heterocycles

Quinazolines are electron-deficient. The C4 position is highly electrophilic.

- Side Reaction: If the reaction is left too long or heated, fluoride ions can act as nucleophiles, attacking the C4 position (especially if a leaving group is present) or causing base-catalyzed degradation of sensitive side chains.
- Mitigation: Strict stoichiometry (1.1 equiv) and temperature control (0°C to RT).

## Experimental Protocols

### Method A: Standard Deprotection (Robust Substrates)

Use this for simple quinazoline-alkynes with no base-sensitive groups.

Reagents:

- Substrate (1.0 equiv)
- TBAF (1.0 M in THF, 1.1–1.2 equiv)
- Solvent: Anhydrous THF (0.1 M concentration)

Step-by-Step:

- Setup: Charge a round-bottom flask with the TMS-protected quinazoline and a magnetic stir bar. Purge with nitrogen.
- Dissolution: Add anhydrous THF to dissolve the substrate.[1]
- Addition: Cool to 0°C (ice bath). Add TBAF solution dropwise via syringe. The solution may darken slightly (yellow/orange) due to trace deprotonation of the product.
- Reaction: Remove ice bath and stir at Room Temperature (RT).
  - Checkpoint: Monitor by TLC after 15 mins. TMS groups usually cleave rapidly (< 30 mins).
- Quench: Once SM is consumed, add 0.5 mL of Saturated NH<sub>4</sub>Cl solution to quench the reaction and protonate any remaining anions.

## Method B: The "Clean" Workup (Dowex/CaCO<sub>3</sub>)

Use this for polar quinazolines where aqueous extraction causes emulsions or product loss.

This method eliminates the "TBAF Blob" without water.[2]

Concept: This protocol uses a sulfonic acid resin to capture the tetrabutylammonium cation and Calcium Carbonate to scavenge the fluoride as insoluble CaF<sub>2</sub>.

Reagents:

- Dowex 50WX8-400 resin (H<sup>+</sup> form, washed with MeOH)

- CaCO<sub>3</sub> (powder)
- Methanol (MeOH)

Protocol:

- Reaction: Perform desilylation as in Method A.
- Scavenging: Do not add water. Instead, add:
  - CaCO<sub>3</sub> (3.0 equiv relative to TBAF)
  - Dowex 50WX8 resin (3.0 g per mmol of TBAF)
  - MeOH (equal volume to THF)
- Incubation: Stir the slurry vigorously for 1 hour at RT.
- Filtration: Filter the mixture through a pad of Celite. Wash the pad with MeOH/DCM (1:1).
- Concentration: Evaporate the filtrate. The residue is usually free of TBA salts and ready for flash chromatography.

Graphviz Diagram 2: Workup Decision Tree

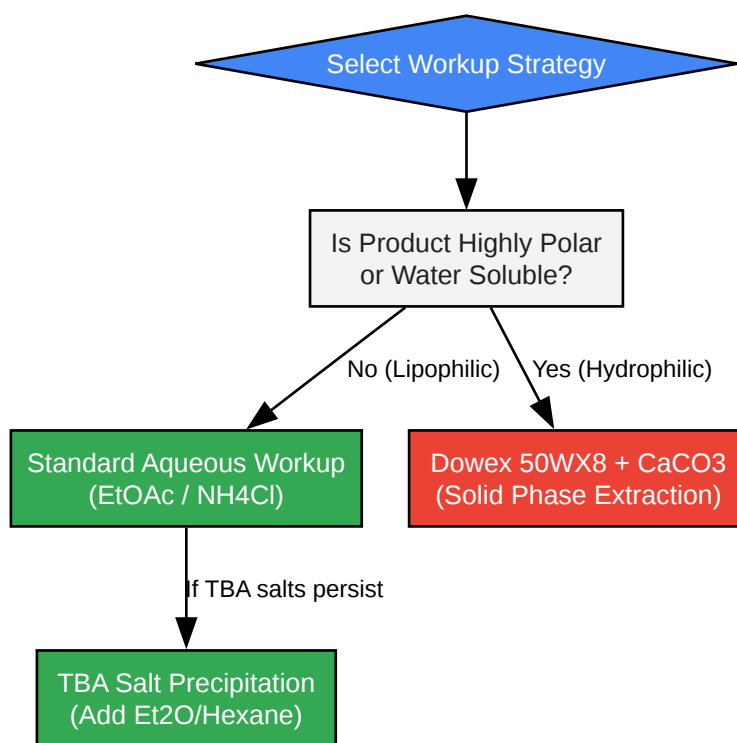

[Click to download full resolution via product page](#)

Caption: Decision matrix for selecting the optimal purification route based on substrate polarity.

## Quantitative Data Summary

Parameter	Standard Condition	Optimized (Sensitive)	Notes
Stoichiometry	1.2 - 1.5 equiv TBAF	1.05 - 1.1 equiv TBAF	Excess TBAF causes side reactions.
Temperature	25°C (RT)	-78°C to 0°C	Low temp prevents nucleophilic attack on quinazoline core.
Time	30 - 60 min	2 - 4 hours	Monitor strictly by TLC.
Solvent	THF	THF / AcOH (10:1)	AcOH buffers basicity for labile groups.
Yield (Typical)	85 - 95%	70 - 85%	Losses often occur during aqueous workup.

## Troubleshooting & Expert Tips

### Removing Residual TBA Salts

If the Dowex method is unavailable and you must use column chromatography:

- The Pre-Wash: Dissolve the crude residue in Et<sub>2</sub>O (if soluble). TBAF and TBA-Cl are generally insoluble in ether. Filter off the solids.[\[3\]](#)[\[4\]](#)[\[5\]](#)[\[6\]](#)
- The Column Flush: Flush your silica column with 1% Triethylamine (TEA) in Hexane before loading. This neutralizes acidic sites on the silica that might bind to the quinazoline nitrogen, improving peak shape.

### Dealing with "Stuck" Reactions

If the TMS group is sterically hindered (e.g., adjacent to a bulky substituent on the quinazoline):

- Switch Reagent: Use TASF (Tris(dimethylamino)sulfonium difluorotrimethylsilicate). It is a non-basic source of soluble fluoride.[\[7\]](#)

- Heat: Warm to 40°C, but monitor for degradation.

## References

- Org. Synth. 2022, 99, 53-67. A Convenient Method for the Removal of Tetrabutylammonium Salts from Desilylation Reactions. [2]
- BenchChem Application Note. TBAF-Mediated Deprotection of TBDMS Ethers: Protocols and Yields.
- J. Med. Chem. 2012, 55, 10, 4788–4805. Discovery of Erlotinib Analogues: Synthesis and Structure-Activity Relationship. (Contextual reference for Quinazoline-Alkyne chemistry).
- Common Organic Chemistry. Tetrabutylammonium Fluoride (TBAF) Reaction Conditions and Safety.

### Need Custom Synthesis?

BenchChem offers custom synthesis for rare earth carbides and specific isotopic labeling.

Email: [info@benchchem.com](mailto:info@benchchem.com) or [Request Quote Online](#).

## Sources

- [1. pdf.benchchem.com](https://pdf.benchchem.com) [pdf.benchchem.com]
- [2. orgsyn.org](https://orgsyn.org) [orgsyn.org]
- [3. reddit.com](https://reddit.com) [reddit.com]
- [4. pdf.benchchem.com](https://pdf.benchchem.com) [pdf.benchchem.com]
- [5. researchgate.net](https://researchgate.net) [researchgate.net]
- [6. An Operationally Simple and Efficient Work-up Procedure for TBAF-mediated Desilylation; Application to Halichondrin Synthesis - PMC](https://pubmed.ncbi.nlm.nih.gov/31111111/) [pmc.ncbi.nlm.nih.gov]
- [7. chemistry.stackexchange.com](https://chemistry.stackexchange.com) [chemistry.stackexchange.com]
- To cite this document: BenchChem. [Application Note: Precision Deprotection of TMS Groups in Quinazoline Synthesis]. BenchChem, [2026]. [Online PDF]. Available at: [https://www.benchchem.com/product/b13463125/docs#application-note-precision-deprotection-of-tms-groups-in-quinazoline-synthesis]

**Disclaimer & Data Validity:**

The information provided in this document is for Research Use Only (RUO) and is strictly not intended for diagnostic or therapeutic procedures. While BenchChem strives to provide accurate protocols, we make no warranties, express or implied, regarding the fitness of this product for every specific experimental setup.

**Technical Support:** The protocols provided are for reference purposes. Unsure if this reagent suits your experiment?

**Need Industrial/Bulk Grade?** [Request Custom Synthesis Quote](#)

## BenchChem

Our mission is to be the trusted global source of essential and advanced chemicals, empowering scientists and researchers to drive progress in science and industry.

### Contact

Address: 3281 E Guasti Rd  
Ontario, CA 91761, United States  
Phone: (601) 213-4426  
Email: [info@benchchem.com](mailto:info@benchchem.com)

[Contact our Ph.D. Support Team for a compatibility check](#)