

Technical Whitepaper: Spectroscopic Characterization of 3,5-Dinitroanisole

Author: BenchChem Technical Support Team. **Date:** May 2026

Compound of Interest

Compound Name: 3,5-Dinitroanisole

CAS No.: 5327-44-6

Cat. No.: B1346779

[Get Quote](#)

Executive Summary

3,5-Dinitroanisole (3,5-DNA) serves as a critical model compound in physical organic chemistry, particularly in the study of nucleophilic aromatic substitution (

) and the formation of Meisenheimer complexes. Unlike its isomer 2,4-DNAN, which is utilized primarily as an insensitive melt-cast explosive ingredient, 3,5-DNA is characterized by its

effective symmetry (planar projection), rendering it an ideal substrate for spectroscopic calibration and mechanistic studies.

This guide details the structural elucidation of 3,5-DNA through Nuclear Magnetic Resonance (

H,

C NMR), Fourier-Transform Infrared (FT-IR), and Ultraviolet-Visible (UV-Vis) spectroscopy.

Structural Logic & Symmetry Analysis

The spectroscopic signature of 3,5-DNA is defined by its symmetry. The molecule possesses a plane of symmetry passing through the methoxy group and the C1-C4 axis of the benzene ring.

- Implication for NMR: The protons at positions 2 and 6 are chemically equivalent, simplifying the splitting patterns compared to the asymmetric 2,4-isomer.
- Implication for Reactivity: The C2, C4, and C6 positions are activated by the electron-withdrawing nitro groups, but the C4 position is sterically distinct, flanked by two nitro groups.

Analytical Workflow

The following diagram outlines the logical flow for validating the identity of 3,5-DNA.

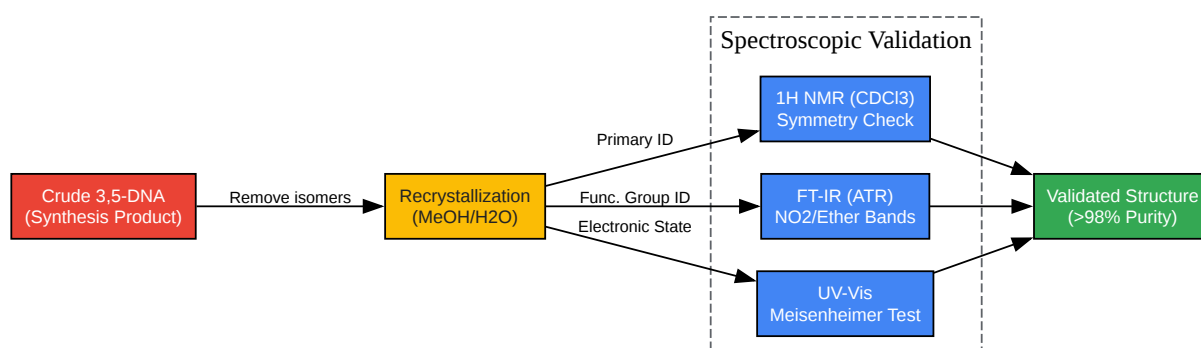

[Click to download full resolution via product page](#)

Figure 1: Analytical workflow for the purification and validation of **3,5-Dinitroanisole**.

Nuclear Magnetic Resonance (NMR)

NMR is the definitive method for distinguishing 3,5-DNA from the 2,4-isomer. The symmetry of 3,5-DNA results in a simple 3-signal proton spectrum.

Proton NMR (^1H)

Solvent: Chloroform-d (

) Reference: TMS (

0.00 ppm)

| Chemical Shift (, ppm) | Multiplicity | Integration | Assignment | Structural Logic |
|-------------------------|---------------|-------------|------------|--|
| 8.70 – 8.85 | Triplet (Hz) | 1H | H-4 | Most deshielded proton. Located between two electron-withdrawing groups. |
| 7.90 – 8.05 | Doublet (Hz) | 2H | H-2, H-6 | Chemically equivalent. Ortho to (shielding) and ortho to (deshielding). |
| 4.00 – 4.05 | Singlet | 3H | -OCH | Characteristic methoxy resonance. |

Interpretation: The key differentiator is the H-4 proton.^[1] Being flanked by two nitro groups, it experiences significant deshielding anisotropy. The coupling constant (

Hz) represents meta-coupling between H-4 and H-2/6.

- Contrast: 2,4-Dinitroanisole would show three distinct aromatic signals (d, dd, d) due to lack of symmetry.

Carbon NMR (C)

Solvent:

[2]

| Chemical Shift (, ppm) | Assignment | Type |
|-------------------------|------------|--|
| 160.5 | C-1 | Quaternary (). Deshielded by oxygen. |
| 149.0 | C-3, C-5 | Quaternary (). Deshielded by nitro groups. |
| 118.5 | C-4 | Methine (). Between nitro groups.[2][3][4][5][6][7][8][9][10] |
| 110.2 | C-2, C-6 | Methine (). Ortho to methoxy. |
| 57.0 | -OCH | Methyl carbon. |

Vibrational Spectroscopy (FT-IR)

The infrared spectrum is dominated by the strong dipoles of the nitro groups. Method: ATR (Attenuated Total Reflectance) or KBr Pellet.

| Wavenumber () | Intensity | Vibrational Mode | Notes |
|----------------|-----------|------------------|--|
| 3100 – 3080 | Weak | | Aromatic C-H stretch. |
| 1535 – 1550 | Strong | | Asymmetric nitro stretch. Diagnostic band. |
| 1340 – 1355 | Strong | | Symmetric nitro stretch. Diagnostic band. |
| 1260 – 1280 | Medium | | Asymmetric ether stretch. |
| 1020 – 1040 | Medium | | Symmetric ether stretch. |

Causality: The shift of the nitro bands compared to nitrobenzene (1520/1345) is due to the combined inductive effects of the second nitro group and the resonance donation of the methoxy group.

Electronic Spectroscopy (UV-Vis) & Meisenheimer Complexes

3,5-DNA is a pale yellow solid, absorbing primarily in the UV region. However, its most significant application is the formation of Meisenheimer complexes (sigma-complexes) upon reaction with nucleophiles (e.g., methoxide, hydroxide).

Neutral Species

- Solvent: Acetonitrile or Methanol[11]
- λ : ~300–330 nm
- Transition:

and

of the nitroaromatic system.

Meisenheimer Complex (Colorimetric Detection)

When treated with a base (e.g., NaOMe), the nucleophile attacks the electron-deficient ring (usually at C-2 or C-4), disrupting aromaticity and forming a resonance-stabilized anionic complex.

- Visual Change: Pale Yellow
Deep Red/Purple.
- (Complex): 480 – 520 nm (Broad charge-transfer band).

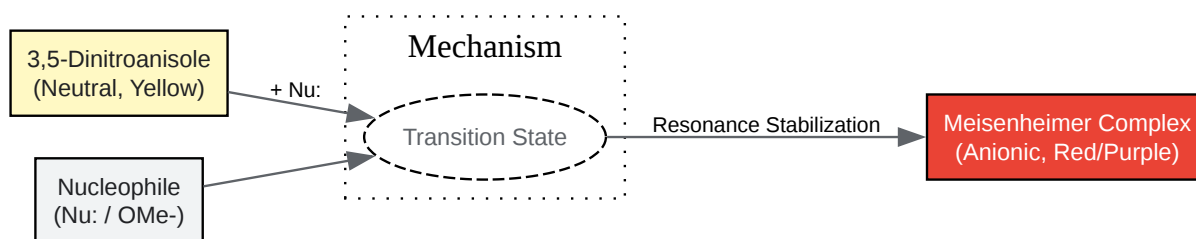

[Click to download full resolution via product page](#)

Figure 2: Reaction pathway for the formation of the colored Meisenheimer complex.

Experimental Protocols

Protocol A: NMR Sample Preparation

To ensure sharp resolution of meta-coupling.

- Mass: Weigh 10–15 mg of dry 3,5-DNA.
- Solvent: Add 0.6 mL of
(Chloroform-d, 99.8% D).
 - Note: If solubility is poor due to high purity crystal lattice energy, use DMSO-

, but expect solvent residual peaks at

2.50.

- Filtration: If the solution is cloudy, filter through a small plug of glass wool in a Pasteur pipette directly into the NMR tube.
- Acquisition: Run standard proton sequence (16 scans) and carbon sequence (256+ scans).

Protocol B: In-Situ Generation of Meisenheimer Complex (UV-Vis)

For demonstrating charge-transfer bands.

- Stock Solution: Prepare a

M solution of 3,5-DNA in Acetonitrile.
- Base Solution: Prepare a 1.0 M solution of NaOH or NaOMe in Methanol.
- Measurement:
 - Fill a quartz cuvette with the Stock Solution.
 - Record the baseline spectrum (200–800 nm).
 - Add 1 drop (~20

L) of Base Solution.
 - Invert to mix and immediately record the spectrum again.
 - Observation: A strong hyperchromic shift in the visible region (480–520 nm) confirms the complex formation.

References

- Spectral Database for Organic Compounds (SDBS). SDBS No. 3478: **3,5-Dinitroanisole**. National Institute of Advanced Industrial Science and Technology (AIST). [[Link](#)]

- Terrier, F. (1982). Rate and Equilibrium Studies of the Formation of Sigma-Complexes (Meisenheimer Complexes). Chemical Reviews, 82(2), 77-152. [[Link](#)]
- NIST Chemistry WebBook.**3,5-Dinitroanisole**: Gas Phase and Condensed Phase Data. [[Link](#)]

Need Custom Synthesis?

BenchChem offers custom synthesis for rare earth carbides and specific isotopic labeling.

Email: info@benchchem.com or [Request Quote Online](#).

Sources

- 1. [researchgate.net](https://www.researchgate.net) [[researchgate.net](https://www.researchgate.net)]
- 2. apps.dtic.mil [apps.dtic.mil]
- 3. NMR Chemical Shifts of Impurities [sigmaaldrich.com]
- 4. utsc.utoronto.ca [utsc.utoronto.ca]
- 5. 2,4-Dinitroanisole - Wikipedia [en.wikipedia.org]
- 6. organicchemistrydata.org [organicchemistrydata.org]
- 7. 2,4-Dinitroanisole - Wikipedia [en.wikipedia.org]
- 8. spectrabase.com [spectrabase.com]
- 9. spectrabase.com [spectrabase.com]
- 10. [researchgate.net](https://www.researchgate.net) [[researchgate.net](https://www.researchgate.net)]
- 11. scs.illinois.edu [scs.illinois.edu]
- To cite this document: BenchChem. [Technical Whitepaper: Spectroscopic Characterization of 3,5-Dinitroanisole]. BenchChem, [2026]. [Online PDF]. Available at: [<https://www.benchchem.com/product/b1346779/docs#technical-whitepaper-spectroscopic-characterization-of-3-5-dinitroanisole>]

Disclaimer & Data Validity:

The information provided in this document is for Research Use Only (RUO) and is strictly not intended for diagnostic or therapeutic procedures. While BenchChem strives to provide accurate protocols, we make no warranties, express or implied, regarding the fitness of this product for every specific experimental setup.

Technical Support: The protocols provided are for reference purposes. Unsure if this reagent suits your experiment?

Need Industrial/Bulk Grade? [Request Custom Synthesis Quote](#)

BenchChem

Our mission is to be the trusted global source of essential and advanced chemicals, empowering scientists and researchers to drive progress in science and industry.

Contact

Address: 3281 E Guasti Rd
Ontario, CA 91761, United States
Phone: (601) 213-4426
Email: info@benchchem.com

[Contact our Ph.D. Support Team for a compatibility check](#)