

Technical Guide: Isomers of Dinitroanisole (DNAN)

Author: BenchChem Technical Support Team. **Date:** May 2026

Compound of Interest

Compound Name: 3,5-Dinitroanisole

CAS No.: 5327-44-6

Cat. No.: B1346779

[Get Quote](#)

Properties, Synthesis, and Toxicological Profiles for Energetic Material Applications

Executive Summary

This technical guide provides a comprehensive analysis of Dinitroanisole (DNAN) isomers, focusing on 2,4-Dinitroanisole (2,4-DNAN) as the primary ingredient in modern Insensitive Munitions (IM). While traditionally used as a dye intermediate, 2,4-DNAN has replaced Trinitrotoluene (TNT) in melt-cast explosive formulations (e.g., IMX-101) due to its superior safety profile and shock insensitivity.^[1]

This document contrasts the physicochemical properties of the relevant isomers, details the industrial synthesis protocol for 2,4-DNAN to ensure high purity, and delineates the metabolic pathways critical for understanding its toxicological impact.

Part 1: Structural Isomerism & Physical Properties

The dinitroanisole molecule consists of a methoxy group (-OCH₃) and two nitro groups (-NO₂) attached to a benzene ring. While six isomers are theoretically possible, 2,4-DNAN is the only

isomer with significant industrial and military application. The other isomers (particularly 2,6-DNAN) appear primarily as impurities that must be managed during synthesis.

Comparative Analysis of Key Isomers

The selection of 2,4-DNAN over others is driven by its melting point.[2] Melt-cast explosives require a carrier fluid that melts between 80°C and 100°C—low enough for safe steam heating but high enough to withstand storage in hot climates.

Property	2,4-Dinitroanisole (Target)	2,6-Dinitroanisole (Impurity)	3,5-Dinitroanisole	TNT (Reference)
CAS Number	119-27-7	3535-67-9	5327-44-6	118-96-7
Melting Point	94–95 °C	~118 °C	105 °C	80.5 °C
Crystal Density	1.34 g/cm ³	1.30 g/cm ³	1.56 g/cm ³	1.65 g/cm ³
Crystal System	Monoclinic ()	-	-	Orthorhombic
Oxygen Balance	-96.9%	-96.9%	-96.9%	-74.0%
Industrial Status	Primary IM Ingredient	Common Byproduct	Rare / Research	Legacy Standard

“

Technical Insight: 2,4-DNAN has a significantly lower density (1.34 g/cm³) compared to TNT (1.65 g/cm³).[3] This results in a lower detonation velocity. To compensate, high-density energetic fillers like RDX or NTO are suspended in the molten DNAN matrix during formulation.

Part 2: Synthesis & Manufacturing Protocol

Direct nitration of anisole is discouraged for high-purity applications because it yields a difficult-to-separate mixture of ortho- and para- isomers (2,4- and 2,6-DNAN). The preferred industrial route is Nucleophilic Aromatic Substitution (

) using 1-chloro-2,4-dinitrobenzene (CDNB). This method is regioselective, safer, and produces higher purity yields.

Protocol: Methoxylation of CDNB

- Precursors: 1-Chloro-2,4-dinitrobenzene (CDNB), Methanol (MeOH), Sodium Hydroxide (NaOH).
- Reaction Type: Nucleophilic Aromatic Substitution ().

Step-by-Step Methodology:

- Preparation of Methoxide:
 - Dissolve NaOH in excess Methanol.
 - Note: While Sodium Methoxide (NaOMe) can be used directly, generating it in situ via NaOH/MeOH is more cost-effective for scale-up.
- Reaction Initiation:
 - Dissolve CDNB in Methanol in a jacketed glass reactor.
 - Heat the CDNB solution to 50–60°C under constant agitation.
- Addition Phase:
 - Slowly add the Methoxide/NaOH solution to the CDNB mixture.
 - Critical Control Point: Maintain temperature below 65°C to prevent thermal runaway or side reactions (hydrolysis to dinitrophenol).
- Reflux & Completion:

- Reflux the mixture for 1–2 hours.
- Monitor consumption of CDNB via HPLC or TLC.
- Quench & Crystallization:
 - Cool the mixture to 5–10°C. DNAN will precipitate as pale yellow needles.
 - Filter the solid product.
- Purification (Removal of Impurities):
 - Wash the filter cake with cold water to remove Sodium Chloride (NaCl) byproduct and residual base.
 - Recrystallize from ethanol or perform a secondary wash with dilute bicarbonate to remove trace 2,4-Dinitrophenol (a toxic hydrolysis impurity).

Synthesis Workflow Diagram

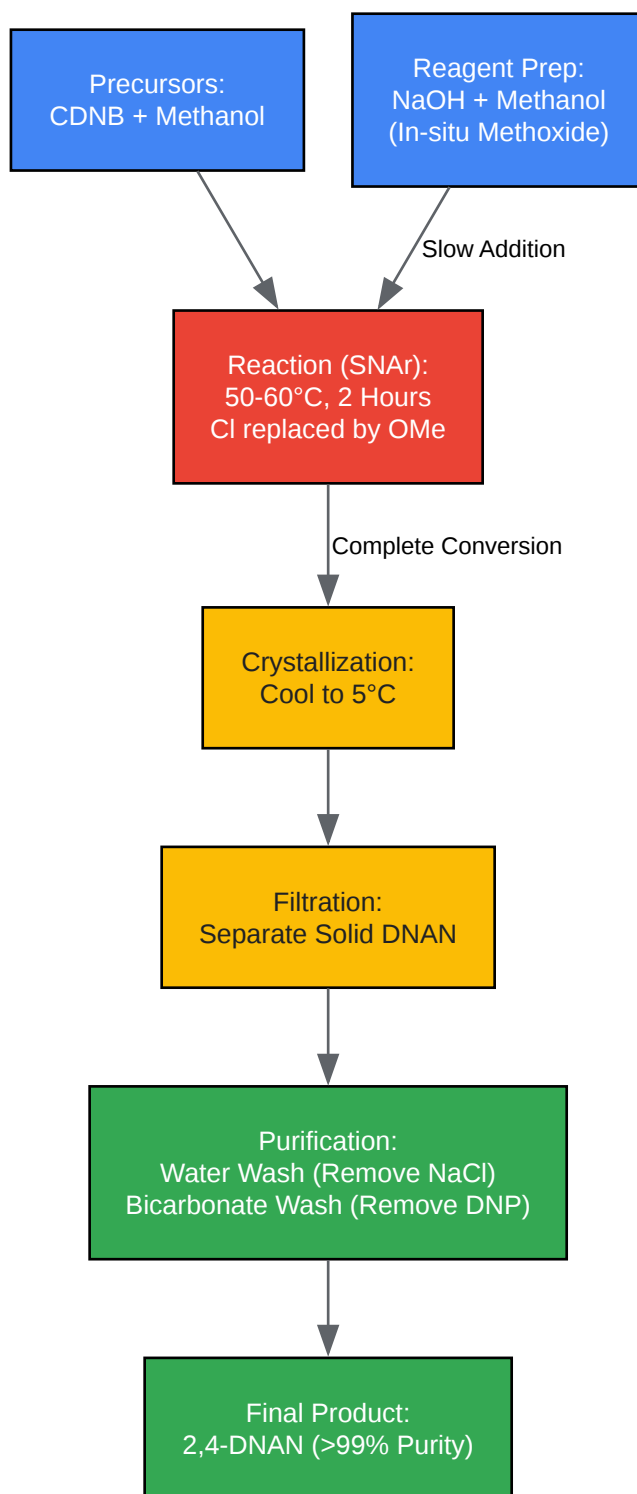

[Click to download full resolution via product page](#)

Figure 1: Industrial synthesis workflow for 2,4-Dinitroanisole via Nucleophilic Aromatic Substitution of CDNB.

Part 3: Toxicology & Environmental Fate[2]

For drug development and safety professionals, understanding the metabolic activation of DNAN is critical. DNAN itself is relatively stable, but its metabolites are biologically active and toxic.

Metabolic Activation: The Lethal Synthesis

DNAN undergoes O-demethylation in the liver (cytochrome P450 mediated) and by environmental bacteria (e.g., *Nocardioides* sp.). This reaction converts DNAN into 2,4-Dinitrophenol (DNP).

- 2,4-Dinitrophenol (DNP): A classic mitochondrial uncoupler. It transports protons across the mitochondrial membrane, bypassing ATP synthase. This collapses the proton gradient, causing energy to be dissipated as heat rather than stored as ATP.
- Clinical Consequence: Uncontrolled hyperthermia (overheating), tachycardia, and metabolic acidosis. There is no specific antidote for DNP poisoning.

Reductive Pathway

Alternatively, the nitro groups can be reduced under anaerobic conditions to form amino-nitroanisoles (e.g., 2-amino-4-nitroanisole). These amines are potential carcinogens (mutagenic in Ames tests).

Metabolic Pathway Diagram

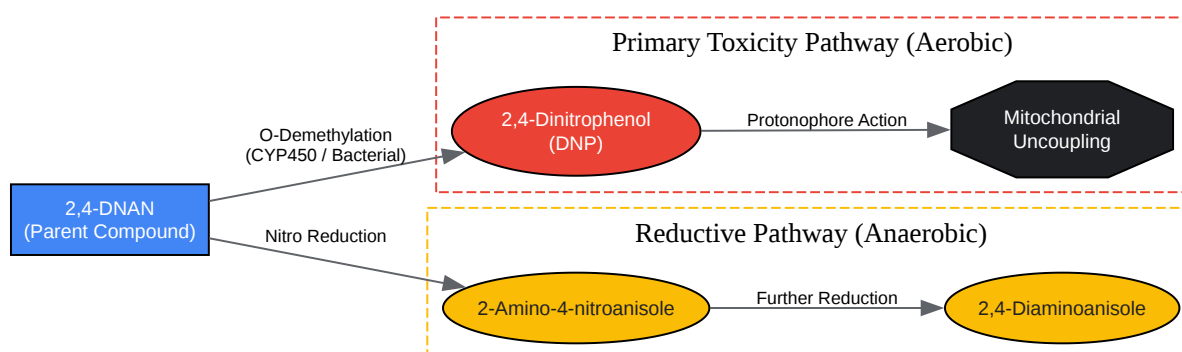

[Click to download full resolution via product page](#)

Figure 2: Metabolic fate of 2,4-DNAN showing the primary toxicological pathway (uncoupling) and reductive pathway.

References

- Davies, P. J., & Provatas, A. (2006). Characterisation of 2,4-Dinitroanisole: An Ingredient for Use in Low Sensitivity Melt Cast Formulations. DSTO Defence Science and Technology Organisation.
- Meng, J., Zhou, L., & Miao, F. (2023).[2] Review of the Essential Characteristics of 2,4-Dinitroanisole. Central European Journal of Energetic Materials.
- Perkins, R. G. (1919). A Study of the Munitions Intoxications in France. Public Health Reports.
- U.S. National Library of Medicine. (2024). 2,4-Dinitroanisole - PubChem Compound Summary. PubChem.[4][5]
- Hawari, J., et al. (2015). Environmental Fate and Ecological Impact of 2,4-Dinitroanisole. SERDP/ESTCP.

Need Custom Synthesis?

BenchChem offers custom synthesis for rare earth carbides and specific isotopic labeling.

Email: info@benchchem.com or [Request Quote Online](#).

Sources

- [1. grokipedia.com \[grokipedia.com\]](https://grokipedia.com)
- [2. wydawnictwa.ipo.lukasiewicz.gov.pl \[wydawnictwa.ipo.lukasiewicz.gov.pl\]](https://wydawnictwa.ipo.lukasiewicz.gov.pl)
- [3. scispace.com \[scispace.com\]](https://scispace.com)
- [4. 2,4-Dinitroanisole | C7H6N2O5 | CID 8385 - PubChem \[pubchem.ncbi.nlm.nih.gov\]](https://pubchem.ncbi.nlm.nih.gov)
- [5. americanelements.com \[americanelements.com\]](https://americanelements.com)

- To cite this document: BenchChem. [Technical Guide: Isomers of Dinitroanisole (DNAN)]. BenchChem, [2026]. [Online PDF]. Available at: [<https://www.benchchem.com/product/b1346779/docs#technical-guide-isomers-of-dinitroanisole-dnan>]

Disclaimer & Data Validity:

The information provided in this document is for Research Use Only (RUO) and is strictly not intended for diagnostic or therapeutic procedures. While BenchChem strives to provide accurate protocols, we make no warranties, express or implied, regarding the fitness of this product for every specific experimental setup.

Technical Support: The protocols provided are for reference purposes. Unsure if this reagent suits your experiment?

Need Industrial/Bulk Grade? [Request Custom Synthesis Quote](#)

BenchChem

Our mission is to be the trusted global source of essential and advanced chemicals, empowering scientists and researchers to drive progress in science and industry.

Contact

Address: 3281 E Guasti Rd
Ontario, CA 91761, United States
Phone: (601) 213-4426
Email: info@benchchem.com

[Contact our Ph.D. Support Team for a compatibility check](#)