

# Application Notes and Protocols for Monitoring Dipropyl Sulfate Reactions

**Author:** BenchChem Technical Support Team. **Date:** December 2025

## Compound of Interest

Compound Name: *Dipropyl sulfate*

Cat. No.: *B1346888*

[Get Quote](#)

For Researchers, Scientists, and Drug Development Professionals

These application notes provide a comprehensive overview of analytical techniques for monitoring reactions involving **dipropyl sulfate**. **Dipropyl sulfate** is a potent alkylating agent and is considered a potential genotoxic impurity (PGI) in pharmaceutical manufacturing. Therefore, robust and sensitive analytical methods are crucial for its control and monitoring to ensure the safety and quality of drug substances and products.

This document details protocols for Gas Chromatography-Mass Spectrometry (GC-MS), High-Performance Liquid Chromatography with UV detection (HPLC-UV), Quantitative Nuclear Magnetic Resonance Spectroscopy (qNMR), and a colorimetric assay for alkylating agents.

## Analytical Techniques Overview

The choice of analytical technique for monitoring **dipropyl sulfate** reactions depends on several factors, including the required sensitivity, the sample matrix, and the purpose of the analysis (e.g., reaction kinetics, impurity profiling, or final product release testing).

- Gas Chromatography-Mass Spectrometry (GC-MS): A highly sensitive and specific method, ideal for detecting and quantifying trace levels of volatile and semi-volatile compounds like **dipropyl sulfate**. The use of Selected Ion Monitoring (SIM) mode enhances sensitivity, making it suitable for genotoxic impurity analysis.

- High-Performance Liquid Chromatography (HPLC) with UV Detection: A versatile and widely used technique in pharmaceutical analysis. While **dipropyl sulfate** lacks a strong chromophore, derivatization can be employed to enhance its UV absorbance, or a universal detector like a Charged Aerosol Detector (CAD) can be used. This method is suitable for monitoring higher concentrations of **dipropyl sulfate** in reaction mixtures.
- Quantitative Nuclear Magnetic Resonance (qNMR) Spectroscopy: A primary analytical method that allows for the quantification of analytes without the need for a specific reference standard of the same compound. It is particularly useful for reaction monitoring and purity assessment, providing structural information simultaneously.
- 4-(4-Nitrobenzyl)pyridine (NBP) Colorimetric Assay: A spectrophotometric method to determine the alkylating activity of a sample. This assay is useful for assessing the overall reactivity of the reaction mixture and can indicate the presence of alkylating agents like **dipropyl sulfate**.

## Data Presentation

The following table summarizes the key quantitative parameters for the described analytical methods. These values are indicative and may vary depending on the specific instrumentation and experimental conditions.

Parameter	GC-MS (SIM mode)	HPLC-UV (with derivatization)	qNMR	NBP Colorimetric Assay
Limit of Detection (LOD)	0.1 - 1 µg/g (ppm)	1 - 10 µg/mL	~0.1% (w/w)	Dependent on alkylating agent reactivity
Limit of Quantitation (LOQ)	0.5 - 5 µg/g (ppm)	5 - 25 µg/mL	~0.3% (w/w)	Dependent on alkylating agent reactivity
Linearity (r <sup>2</sup> )	> 0.99	> 0.99	> 0.999	> 0.99
Accuracy (% Recovery)	90 - 110%	95 - 105%	98 - 102%	90 - 110%
Precision (% RSD)	< 15%	< 5%	< 2%	< 10%

## Experimental Protocols

### Sample Preparation Protocol for Drug Substances

This protocol describes a general procedure for preparing a drug substance sample for analysis.

- **Weighing:** Accurately weigh approximately 100 mg of the drug substance into a suitable volumetric flask (e.g., 10 mL).
- **Dissolution:** Add a suitable diluent (e.g., methylene chloride for GC-MS, or a mobile phase constituent for HPLC) to dissolve the sample. Use about 70% of the final volume.
- **Sonication:** Sonicate the flask for 5-10 minutes to ensure complete dissolution.
- **Dilution to Volume:** Allow the solution to return to room temperature and dilute to the mark with the diluent. Mix thoroughly.
- **Filtration (if necessary):** If the solution is not clear, filter it through a 0.45 µm syringe filter compatible with the diluent.

- Further Dilution: Based on the expected concentration of **dipropyl sulfate** and the sensitivity of the analytical method, a further dilution of this stock solution may be necessary.

## GC-MS Method for Dipropyl Sulfate Quantification

This protocol is adapted from methods developed for similar alkylating agents and is suitable for trace-level quantification.<sup>[1][2]</sup>

Instrumentation:

- Gas Chromatograph coupled to a Mass Spectrometer (GC-MS)
- Column: DB-1 (100% dimethyl polysiloxane), 30 m x 0.32 mm ID, 1.0 µm film thickness (or equivalent)

GC Conditions:

- Injector Temperature: 250 °C
- Injection Volume: 1 µL (splitless mode)
- Carrier Gas: Helium at a constant flow of 1.5 mL/min
- Oven Temperature Program:
  - Initial temperature: 60 °C, hold for 2 minutes
  - Ramp: 10 °C/min to 220 °C
  - Hold: 5 minutes at 220 °C

MS Conditions:

- Ionization Mode: Electron Impact (EI), 70 eV
- Source Temperature: 230 °C
- Acquisition Mode: Selected Ion Monitoring (SIM)

- Ions to Monitor (for **Dipropyl Sulfate**):
  - Quantification ion:  $m/z$  155 ( $M-C_3H_7O$ )<sup>+</sup>
  - Qualifier ions:  $m/z$  182 ( $M$ )<sup>+</sup>,  $m/z$  97 ( $SO_4H$ )<sup>+</sup> (Note: Fragmentation patterns should be confirmed with a standard)

#### Data Analysis:

- Create a calibration curve by injecting standard solutions of **dipropyl sulfate** at different concentrations.
- Quantify **dipropyl sulfate** in samples by comparing the peak area of the quantification ion to the calibration curve.
- Confirm the identity of the peak by verifying the retention time and the ratio of the qualifier ions to the quantification ion.

## HPLC-UV Method for Dipropyl Sulfate Monitoring (with Derivatization)

This protocol involves a pre-column derivatization step to enhance the UV detectability of **dipropyl sulfate**. Sodium phenoxide is used as a derivatizing agent.[3]

#### Instrumentation:

- High-Performance Liquid Chromatograph with a UV detector
- Column: C18, 250 mm x 4.6 mm, 5  $\mu$ m particle size (or equivalent)

#### Reagents:

- Derivatizing reagent: 0.1 M Sodium Phenoxide in methanol
- Mobile Phase A: Water
- Mobile Phase B: Acetonitrile

- Diluent: Acetonitrile/Water (50:50, v/v)

#### Derivatization Protocol:

- To 1 mL of the sample solution (or standard), add 0.5 mL of the 0.1 M sodium phenoxide solution.
- Cap the vial and heat at 60 °C for 30 minutes.
- Cool the solution to room temperature before injection.

#### HPLC Conditions:

- Mobile Phase: Gradient elution (e.g., Start with 70% A, ramp to 30% A over 15 minutes)
- Flow Rate: 1.0 mL/min
- Column Temperature: 30 °C
- Injection Volume: 10 µL
- Detection Wavelength: 218 nm (for the phenyl propyl ether derivative)

#### Data Analysis:

- Prepare a calibration curve using derivatized standards of **dipropyl sulfate**.
- Quantify the derivatized **dipropyl sulfate** in the samples based on the calibration curve.

## Quantitative NMR (qNMR) Protocol for Reaction Monitoring

This protocol provides a general framework for using qNMR to monitor the progress of a reaction involving **dipropyl sulfate**.<sup>[4][5][6]</sup>

#### Instrumentation:

- NMR Spectrometer (e.g., 400 MHz or higher)

#### Reagents:

- Deuterated solvent (e.g.,  $\text{CDCl}_3$ ,  $\text{DMSO-d}_6$ ) compatible with the reaction.
- Internal Standard (IS): A stable compound with a known purity and a signal that does not overlap with the signals of the reactants or products (e.g., maleic acid, 1,3,5-trimethoxybenzene).

#### Sample Preparation for qNMR:

- Accurately weigh a known amount of the internal standard into an NMR tube.
- At specific time points during the reaction, withdraw a precise aliquot of the reaction mixture.
- Add the aliquot to the NMR tube containing the internal standard.
- Add the deuterated solvent to the required volume.
- Mix thoroughly.

#### NMR Acquisition Parameters:

- Pulse Program: A standard  $90^\circ$  pulse sequence.
- Relaxation Delay ( $d_1$ ): Should be at least 5 times the longest  $T_1$  of the signals of interest (both analyte and internal standard) to ensure full relaxation. A typical starting value is 30 seconds.
- Number of Scans ( $ns$ ): Sufficient to obtain a good signal-to-noise ratio (e.g., 8 or 16 scans).

#### Data Processing and Analysis:

- Process the spectra with appropriate phasing and baseline correction.
- Integrate a well-resolved signal for **dipropyl sulfate**, a signal for a product, and the signal for the internal standard.

- Calculate the concentration of **dipropyl sulfate** at each time point using the following equation:

$$C_x = (I_x / N_x) * (N_{is} / I_{is}) * (M_x / M_{is}) * (m_{is} / V) * P_{is}$$

Where:

- $C_x$  = Concentration of analyte (**dipropyl sulfate**)
  - $I_x$  = Integral of the analyte signal
  - $N_x$  = Number of protons for the analyte signal
  - $I_{is}$  = Integral of the internal standard signal
  - $N_{is}$  = Number of protons for the internal standard signal
  - $M_x$  = Molar mass of the analyte
  - $M_{is}$  = Molar mass of the internal standard
  - $m_{is}$  = Mass of the internal standard
  - $V$  = Volume of the reaction aliquot
  - $P_{is}$  = Purity of the internal standard
- Plot the concentration of **dipropyl sulfate** versus time to obtain the reaction kinetics.

## 4-(4-Nitrobenzyl)pyridine (NBP) Colorimetric Assay Protocol

This assay provides a semi-quantitative measure of the alkylating activity of the sample. The reaction of an alkylating agent with NBP forms a colored product upon addition of a base.<sup>[7][8]</sup>

Instrumentation:

- UV-Vis Spectrophotometer



**Reagents:**

- NBP solution: 5% (w/v) 4-(4-nitrobenzyl)pyridine in a suitable solvent (e.g., acetone).
- Buffer solution: e.g., acetate buffer, pH 4.5.
- Base: e.g., 1 M triethylamine in acetone.

**Protocol:**

- Pipette 1 mL of the sample solution into a test tube.
- Add 0.5 mL of the buffer solution.
- Add 0.2 mL of the NBP solution.
- Heat the mixture at 100 °C for 10 minutes.
- Cool the tube rapidly in an ice bath.
- Add 2 mL of the base solution and mix.
- Measure the absorbance of the resulting blue color at the wavelength of maximum absorbance (typically around 600 nm) against a reagent blank.

**Data Analysis:**

- Prepare a calibration curve using a known alkylating agent as a standard.
- Determine the alkylating equivalents in the sample by comparing its absorbance to the calibration curve.

## Visualizations

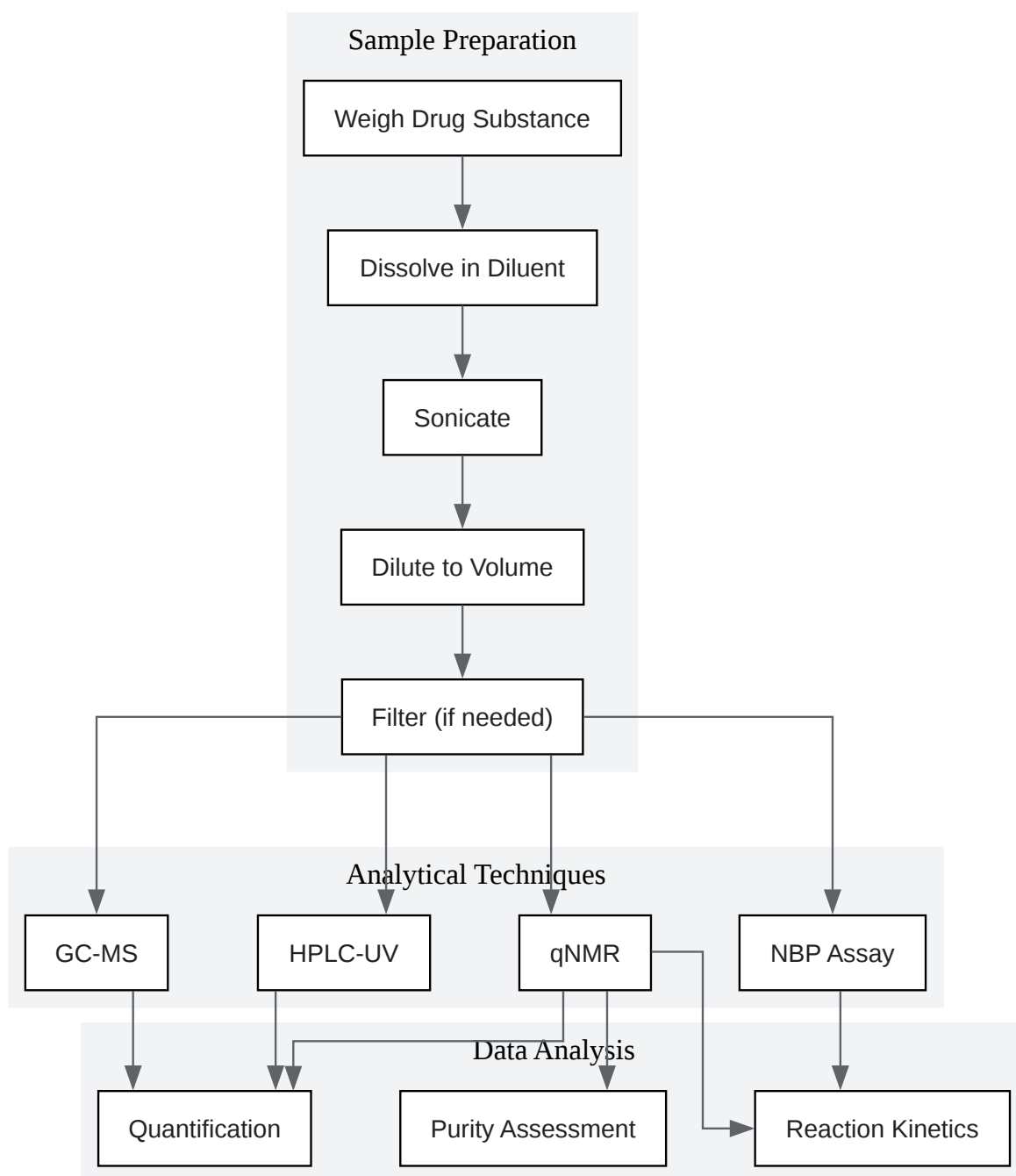

[Click to download full resolution via product page](#)

Caption: General experimental workflow for monitoring **dipropyl sulfate**.

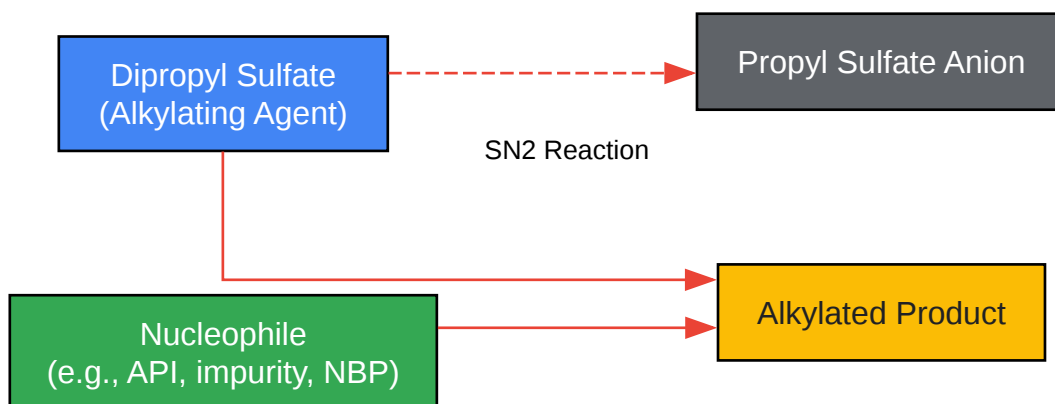

[Click to download full resolution via product page](#)

Caption: SN2 reaction pathway of **dipropyl sulfate** with a nucleophile.

### Need Custom Synthesis?

BenchChem offers custom synthesis for rare earth carbides and specific isotopic labeling.

Email: [info@benchchem.com](mailto:info@benchchem.com) or [Request Quote Online](#).

## References

- 1. [pharmainfo.in](http://pharmainfo.in) [[pharmainfo.in](http://pharmainfo.in)]
- 2. [ijppr.humanjournals.com](http://ijppr.humanjournals.com) [[ijppr.humanjournals.com](http://ijppr.humanjournals.com)]
- 3. Synthesis and Performance of a Biomimetic Indicator for Alkylating Agents - PubMed [[pubmed.ncbi.nlm.nih.gov](http://pubmed.ncbi.nlm.nih.gov)]
- 4. Quantitative NMR Assays (qNMR) | Bruker [[bruker.com](http://bruker.com)]
- 5. [nmr.chem.ox.ac.uk](http://nmr.chem.ox.ac.uk) [[nmr.chem.ox.ac.uk](http://nmr.chem.ox.ac.uk)]
- 6. Quantitative NMR (qNMR) — Nanalysis [[nanalysis.com](http://nanalysis.com)]
- 7. [rroj.com](http://rroj.com) [[rroj.com](http://rroj.com)]
- 8. Improving the spectrophotometric determination of the alkylating activity of anticancer agents: a new insight into the mechanism of the NBP method - PubMed [[pubmed.ncbi.nlm.nih.gov](http://pubmed.ncbi.nlm.nih.gov)]
- To cite this document: BenchChem. [Application Notes and Protocols for Monitoring Dipropyl Sulfate Reactions]. BenchChem, [2025]. [Online PDF]. Available at:

[<https://www.benchchem.com/product/b1346888#analytical-techniques-for-monitoring-dipropyl-sulfate-reactions>]

---

### Disclaimer & Data Validity:

The information provided in this document is for Research Use Only (RUO) and is strictly not intended for diagnostic or therapeutic procedures. While BenchChem strives to provide accurate protocols, we make no warranties, express or implied, regarding the fitness of this product for every specific experimental setup.

**Technical Support:** The protocols provided are for reference purposes. Unsure if this reagent suits your experiment? [[Contact our Ph.D. Support Team for a compatibility check](#)]

**Need Industrial/Bulk Grade?** [Request Custom Synthesis Quote](#)

## BenchChem

Our mission is to be the trusted global source of essential and advanced chemicals, empowering scientists and researchers to drive progress in science and industry.

### Contact

Address: 3281 E Guasti Rd  
Ontario, CA 91761, United States  
Phone: (601) 213-4426  
Email: [info@benchchem.com](mailto:info@benchchem.com)