

Application Note: 2-Demethylcolchicine – Metabolic Profiling and Tubulin Interaction Kinetics

Author: BenchChem Technical Support Team. **Date:** May 2026

Compound of Interest

Compound Name: 2-Demethylcolchicine

CAS No.: 7336-36-9

Cat. No.: B1346099

[Get Quote](#)

Abstract

2-Demethylcolchicine (2-DMC), a primary Phase I metabolite of the alkaloid colchicine, serves as a critical biomarker for CYP3A4 activity and a reference standard in tubulin-binding structure-activity relationship (SAR) studies. Unlike its isomer 3-demethylcolchicine, 2-DMC exhibits significantly reduced tubulin-binding affinity, making it an essential negative control in potency assays. This application note details validated protocols for the LC-MS/MS quantification of 2-DMC in biological matrices and fluorescence-based kinetic assays to characterize its interaction with the colchicine-binding site (CBS) on

-tubulin.

Introduction & Chemical Context

Colchicine is a potent microtubule-destabilizing agent used in the treatment of gout and Familial Mediterranean Fever.[1] Its narrow therapeutic index requires rigorous metabolic

profiling. The primary metabolic pathway involves demethylation by Cytochrome P450 3A4 (CYP3A4), yielding two major monophenolic metabolites:

- 3-Demethylcolchicine (3-DMC): Retains high tubulin-binding affinity and cytotoxicity.
- **2-Demethylcolchicine (2-DMC)**: The focus of this guide, characterized by an O-demethylation at the A-ring (position 2). It displays markedly reduced biological activity, providing a unique tool for understanding the pharmacophore requirements of the CBS.

Key Chemical Properties

Property	Specification
CAS Number	102491-80-5
Molecular Formula	C H NO
Molecular Weight	385.41 g/mol
Solubility	Methanol, DMSO, Chloroform (Slightly)
Stability	Light Sensitive (Protect from UV/Ambient light); Store at -20°C
Appearance	Yellow Solid

Metabolic Pathway Visualization

The following diagram illustrates the CYP3A4-mediated biotransformation of colchicine.

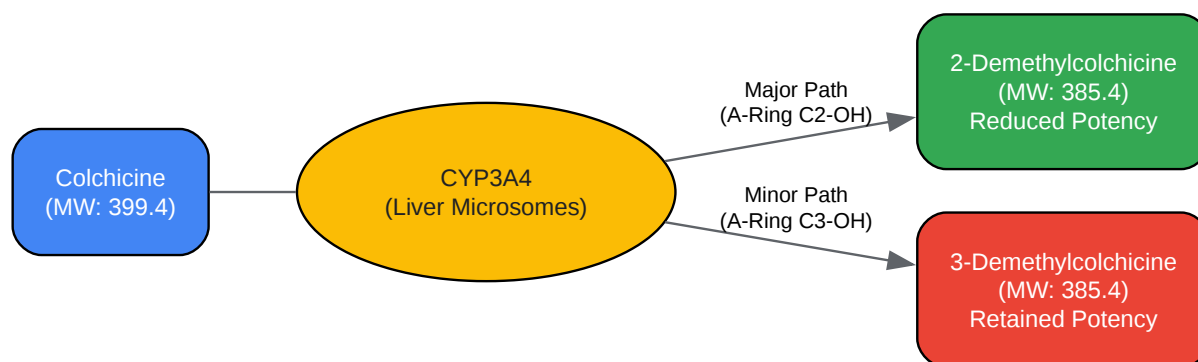

[Click to download full resolution via product page](#)

Figure 1: CYP3A4-mediated demethylation of Colchicine. Note the divergence into 2-DMC and 3-DMC.

Experimental Protocols

Module A: LC-MS/MS Quantification of 2-DMC

Objective: To quantify 2-DMC levels in human liver microsomes (HLM) or plasma for metabolic stability or pharmacokinetic studies.

1. Method Principle

2-DMC is extracted using liquid-liquid extraction (LLE) or protein precipitation. Detection is achieved via Triple Quadrupole MS using Multiple Reaction Monitoring (MRM).[2] The loss of the acetyl group is the primary fragmentation pathway, similar to the parent compound.

2. Instrument Parameters

- System: UHPLC coupled to Triple Quadrupole MS (e.g., Agilent 6400 series or Sciex QTRAP).
- Column: C18 Reverse Phase (e.g., Zorbax Eclipse Plus, 2.1 x 50 mm, 1.8 μ m).
- Mobile Phase A: 0.1% Formic Acid in Water.
- Mobile Phase B: 0.1% Formic Acid in Acetonitrile.

- Gradient: 10% B to 90% B over 3.0 min.

3. MRM Transitions (Optimized)

Analyte	Precursor Ion ()	Product Ion ()	Collision Energy (V)	Role
2-Demethylcolchicine	386.2 [M+H]	344.2	25	Quantifier
386.2 [M+H]	326.1	35	Qualifier	
Colchicine (IS)	400.2 [M+H]	358.2	25	Internal Std

Note: 2-DMC is 14 Da lighter than Colchicine due to the loss of a methyl group (-CH₃).

4. Sample Preparation Protocol

- Thawing: Thaw plasma or microsomal samples at room temperature (protected from light).
- Precipitation: Add 100 μ L of sample to 300 μ L of ice-cold Acetonitrile containing Internal Standard (Deuterated Colchicine or unlabeled Colchicine if separating chromatographically).
- Vortex: Vortex vigorously for 30 seconds.
- Centrifugation: Centrifuge at 14,000 x g for 10 minutes at 4°C.
- Injection: Transfer 100 μ L of supernatant to an amber autosampler vial. Inject 2-5 μ L.

Module B: In Vitro Tubulin Polymerization Assay

Objective: To demonstrate the reduced binding affinity of 2-DMC compared to Colchicine. This assay validates the structural requirement of the 2-methoxy group for high-affinity tubulin binding.

1. Reagents

- Purified Tubulin: >99% pure from bovine brain (10 mg/mL stock).
- GTP Stock: 100 mM Guanosine Triphosphate.
- PEM Buffer: 80 mM PIPES (pH 6.9), 2 mM MgCl₂, 0.5 mM EGTA.
- Reporter: DAPI (4',6-diamidino-2-phenylindole) or turbidity measurement at 340 nm.

2. Experimental Workflow

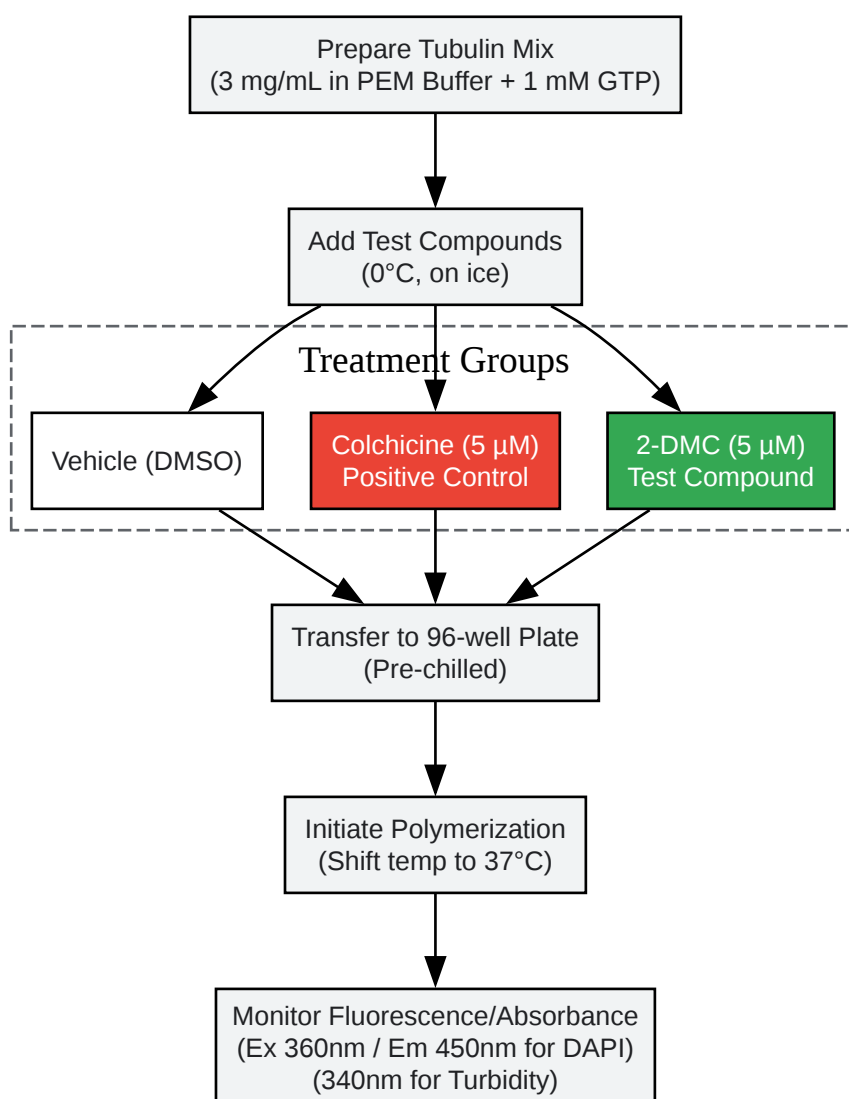

[Click to download full resolution via product page](#)

Figure 2: Tubulin Polymerization Inhibition Workflow.

3. Detailed Procedure

- Preparation: Dilute tubulin to 3.0 mg/mL in PEM buffer containing 1 mM GTP. Keep on ice.
- Compound Addition:
 - Control: Add DMSO (1% v/v final).
 - Standard: Add Colchicine (Final concentration 5 μ M).
 - Test: Add **2-Demethylcolchicine** (Final concentration 5 μ M).
- Incubation: Transfer 100 μ L/well into a pre-chilled 96-well half-area plate.
- Measurement: Place in a plate reader pre-heated to 37°C.
- Kinetics: Measure absorbance at 340 nm (turbidity) every 30 seconds for 60 minutes.
- Analysis: Calculate the

(rate of polymerization) and the % Inhibition relative to the Vehicle control.

4. Expected Results

- Vehicle: Rapid increase in OD340 (sigmoidal curve) indicating microtubule assembly.
- Colchicine (5 μ M): Flat line or very slow increase (Complete inhibition).
- 2-DMC (5 μ M): Partial inhibition or curve similar to vehicle (Reduced potency). Note: 2-DMC typically requires 10-50x higher concentrations to achieve the same inhibition as Colchicine.

Comparative Data Summary

The following table summarizes the biological and chemical distinctions between the parent compound and the 2-DMC metabolite.

Parameter	Colchicine (Parent)	2-Demethylcolchicine (Metabolite)
Tubulin Binding Site	High Affinity (K ~ 0.5 μ M)	Low Affinity
IC (MCF-7 Cells)	~10 nM	> 100 nM
Primary Metabolism	Substrate of CYP3A4/P-gp	Product of CYP3A4
Fluorescence	Low intrinsic fluorescence	Enhanced fluorescence upon tubulin binding
Toxicity Profile	High (GI/Neuromuscular)	Reduced Cytotoxicity

References

- Tateishi, T., et al. (1997). "Colchicine biotransformation by human liver microsomes. Identification of CYP3A4 as the major isoform responsible for colchicine demethylation." *Biochemical Pharmacology*.
- Rösner, M., et al. (1981). "Biological effects of modified colchicines. Improved preparation of **2-demethylcolchicine**... and binding to microtubule protein." *Journal of Medicinal Chemistry*.
- Bhattacharyya, B., et al. (2008). "Colchicine-tubulin interaction: An update." *The FEBS Journal*. (Provides context on the binding site requirements).
- FDA Adverse Event Reporting System (FAERS). "Drugs That Interact With Colchicine Via Inhibition of Cytochrome P450 3A4."

Need Custom Synthesis?

BenchChem offers custom synthesis for rare earth carbides and specific isotopic labeling.

Email: info@benchchem.com or [Request Quote Online](#).

Sources

- 1. Cytotoxic, analgesic and anti-inflammatory activity of colchicine and its C-10 sulfur containing derivatives - PMC [[pmc.ncbi.nlm.nih.gov](https://pubmed.ncbi.nlm.nih.gov/)]
- 2. forensicrti.org [forensicrti.org]
- To cite this document: BenchChem. [Application Note: 2-Demethylcolchicine – Metabolic Profiling and Tubulin Interaction Kinetics]. BenchChem, [2026]. [Online PDF]. Available at: [<https://www.benchchem.com/product/b1346099/docs#application-note-2-demethylcolchicine-metabolic-profiling-and-tubulin-interaction-kinetics>]

Disclaimer & Data Validity:

The information provided in this document is for Research Use Only (RUO) and is strictly not intended for diagnostic or therapeutic procedures. While BenchChem strives to provide accurate protocols, we make no warranties, express or implied, regarding the fitness of this product for every specific experimental setup.

Technical Support: The protocols provided are for reference purposes. Unsure if this reagent suits your experiment?

Need Industrial/Bulk Grade? [Request Custom Synthesis Quote](#)

BenchChem

Our mission is to be the trusted global source of essential and advanced chemicals, empowering scientists and researchers to drive progress in science and industry.

Contact

Address: 3281 E Guasti Rd

Ontario, CA 91761, United States

Phone: (601) 213-4426

Email: info@benchchem.com

Contact our Ph.D. Support Team for a compatibility check