

Strategic Functionalization of 1-Isopropyl-3-Methylpyrazole: A Modular C4-Targeting Guide

Author: BenchChem Technical Support Team. **Date:** May 2026

Compound of Interest

Compound Name: (1-Isopropyl-3-methyl-1H-pyrazol-4-yl)boronic acid

Cat. No.: B13454077

[Get Quote](#)

Executive Summary

The 1-isopropyl-3-methylpyrazole scaffold is a privileged pharmacophore in medicinal chemistry, widely utilized in kinase inhibitors (e.g., JAK, BRAF) and agrochemicals. While the N1-isopropyl group provides essential lipophilicity and the C3-methyl group offers metabolic stability, the C4-position represents the primary vector for expanding chemical complexity.

This application note provides a definitive guide to functionalizing the C4-position. Unlike the acidic C5-position, which is prone to deprotonation, the C4-position is nucleophilic.^[1] Consequently, our strategy relies on Electrophilic Aromatic Substitution (EAS) as the primary gateway. We present validated protocols for Halogenation (the "Gateway Transformation"), Suzuki-Miyaura Cross-Coupling, and Vilsmeier-Haack Formylation, ensuring high regioselectivity and yield.

The Reactivity Landscape

To successfully functionalize this substrate, one must understand the electronic bias of the pyrazole ring.

- C4-Position (Nucleophilic): The lone pair on N1 donates electron density into the ring, creating a significant negative electrostatic potential at C4. This makes C4 the exclusive site for electrophilic attack (EAS).
- C5-Position (Acidic): The proton at C5 is the most acidic (in DMSO) due to the inductive effect of the adjacent N1. Direct lithiation (e.g., $n\text{-BuLi}$) will exclusively deprotonate C5, not C4.

Diagram 1: Reactivity Map & Decision Tree

This diagram illustrates the divergent pathways based on reagent choice.

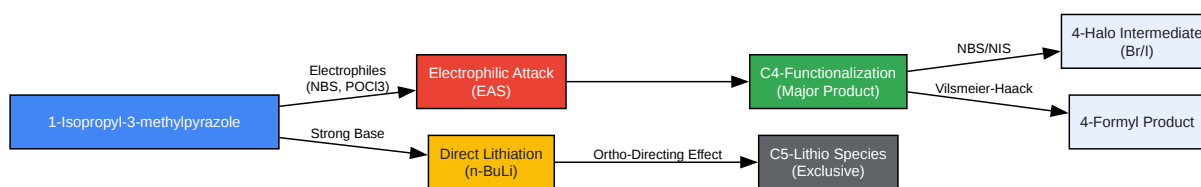

[Click to download full resolution via product page](#)

Figure 1: Reactivity bifurcation. Electrophiles target C4, while strong bases target C5. To functionalize C4 via organometallics, one must first halogenate C4, then perform Lithium-Halogen Exchange.

Module A: The Gateway Transformation (Regioselective Halogenation)

The most robust method to access C4-derivatives is via a 4-halo intermediate. This enables subsequent Palladium-catalyzed cross-couplings.

Mechanistic Insight

While elemental bromine (

) can be used, it often leads to hydrobromide salts that complicate workup or cause acid-catalyzed side reactions. N-Bromosuccinimide (NBS) is the superior reagent, providing a controlled source of electrophilic bromine (

) without generating strong acid byproducts.

Protocol 1: C4-Bromination with NBS

Target: 4-Bromo-1-isopropyl-3-methylpyrazole

Reagents:

- Substrate: 1-Isopropyl-3-methylpyrazole (1.0 equiv)
- Reagent: N-Bromosuccinimide (NBS) (1.05 equiv)
- Solvent: Acetonitrile (MeCN) or DMF (0.5 M concentration)

Step-by-Step Procedure:

- Preparation: Dissolve 1-isopropyl-3-methylpyrazole (10 mmol) in anhydrous MeCN (20 mL) in a round-bottom flask shielded from light (wrap in foil).
- Addition: Cool the solution to 0°C. Add NBS (10.5 mmol) portion-wise over 15 minutes. Note: Exothermic reaction.[2]
- Reaction: Allow the mixture to warm to room temperature (RT) and stir for 2–4 hours.
- Monitoring: Check TLC (Hexane/EtOAc 4:1). The starting material (higher R_f) should disappear, replaced by the product (lower R_f).
- Workup: Concentrate the solvent under reduced pressure. Resuspend the residue in EtOAc and wash with water (3x) and brine (3x) to remove succinimide byproduct.

- Purification: Dry over

, filter, and concentrate. The crude product is typically

pure. If necessary, purify via silica gel flash chromatography (0-20% EtOAc in Hexanes).

Expected Yield: 90–98%

Module B: Carbon-Carbon Bond Formation (Suzuki-Miyaura Coupling)[3]

Once the 4-bromo or 4-iodo derivative is secured, the Suzuki-Miyaura coupling is the industry standard for installing aryl or heteroaryl groups.

Protocol 2: Pd-Catalyzed Cross-Coupling

Target: 4-Aryl-1-isopropyl-3-methylpyrazole

Reagents:

- Substrate: 4-Bromo-1-isopropyl-3-methylpyrazole (1.0 equiv)
- Boronic Acid: Aryl-B(OH)₂ (1.2 equiv)
- Catalyst:

(3–5 mol%)
- Base:

or

(2.0 equiv)
- Solvent: 1,4-Dioxane/Water (4:1 ratio)

Step-by-Step Procedure:

- Assembly: In a microwave vial or pressure tube, combine the 4-bromo substrate, boronic acid, and base.

- Solvent & Degassing: Add the Dioxane/Water mixture. Sparge with Argon or Nitrogen gas for 10 minutes. Critical: Oxygen inhibits the Pd cycle.
- Catalyst Addition: Add the Pd catalyst quickly and seal the vessel under inert atmosphere.
- Reaction: Heat to 90°C (oil bath) or 100°C (Microwave) for 1–3 hours.
- Workup: Filter through a Celite pad to remove Palladium black. Dilute with EtOAc, wash with water.
- Purification: Flash chromatography (Hexane/EtOAc gradient).

Diagram 2: Suzuki Coupling Workflow

Visualizing the critical path for C-C bond formation.

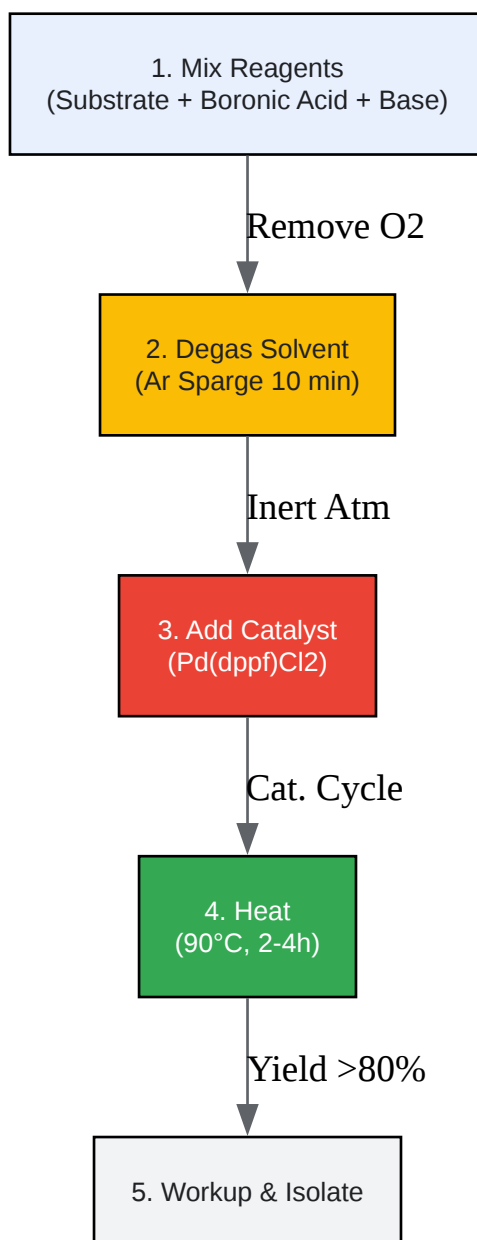

[Click to download full resolution via product page](#)

Figure 2: Standard workflow for Suzuki-Miyaura coupling of 4-halopyrazoles.

Module C: Vilsmeier-Haack Formylation[2][4][5]

To install a carbon atom at C4 without a metal catalyst, the Vilsmeier-Haack reaction is the method of choice, yielding an aldehyde (-CHO) that serves as a versatile handle for reductive amination.

Protocol 3: C4-Formylation

Target: 1-Isopropyl-3-methylpyrazole-4-carbaldehyde

Reagents:

- Substrate: 1-Isopropyl-3-methylpyrazole (1.0 equiv)
- Reagent:
(1.2 equiv)[2]
- Solvent: DMF (3.0 equiv, acts as reagent and solvent)

Step-by-Step Procedure:

- Vilsmeier Reagent Formation: Cool anhydrous DMF (3 mL per mmol substrate) to 0°C. Add dropwise. Stir for 30 mins at 0°C to form the chloroiminium salt (white precipitate may form).
- Addition: Add the pyrazole substrate (dissolved in minimal DMF) dropwise to the cold reagent mixture.
- Heating: Warm to RT, then heat to 60–80°C for 3 hours.
- Quench (Critical): Cool to RT. Pour the reaction mixture slowly onto crushed ice/saturated Sodium Acetate solution. Caution: Vigorous exotherm.
- Neutralization: Adjust pH to ~7–8 with
.
- Isolation: Extract with
(
). Wash organics with water (to remove DMF) and brine.
- Result: The aldehyde is usually obtained as a solid or oil, often pure enough for subsequent steps.

Expert Insight: The Lithiation Trap (Avoid C5)

A common error in pyrazole chemistry is attempting direct lithiation to functionalize C4.

- The Problem: If you treat 1-isopropyl-3-methylpyrazole with n -BuLi, the Nitrogen lone pair directs the lithium to the C5 position (Ortho-Lithiation). Quenching this with an electrophile (e.g., RCHO , aldehydes) will yield the C5-substituted product, not C4.
- The Solution: To use organometallic chemistry at C4, you must use the Halogen-Metal Exchange route.
 - Synthesize 4-bromo-1-isopropyl-3-methylpyrazole (via Module A).
 - Treat with n -BuLi or n -PrMgCl at -78°C . The Lithium/Magnesium will selectively exchange with the Bromine at C4.
 - Quench with electrophile.

Reagent Comparison Table

Transformation	Reagent System	Selectivity (C4:C5)	Yield	Key Advantage
Bromination	NBS, MeCN, RT	>99:1	95%	Mild, no acid byproducts, scalable.[3]
Iodination	NIS, MeCN, RT	>99:1	92%	Reactive handle for difficult couplings.
Formylation	, DMF	>99:1	85%	Atom-economical access to aldehydes.
Nitration	,	>95:5	80%	Precursor to 4-amino pyrazoles.
Direct Lithiation	-BuLi, THF	0:100 (C5 only)	N/A	Do not use for C4 targets.

References

- Review of Pyrazole Reactivity: Fustero, S., et al. "From 2000 to Mid-2010: A Fruitful Decade for the Synthesis of Pyrazoles." Chemical Reviews, 2011.
- Regioselective Halogenation: Bovonsombat, P., et al. "Use of N-Bromosuccinimide for Regioselective Bromination of Aromatic Compounds." Tetrahedron Letters, 2009.
- Suzuki Coupling on Pyrazoles: Kudo, N., et al. "Efficient Synthesis of 4-Arylpyrazoles via Suzuki-Miyaura Coupling." Chemical and Pharmaceutical Bulletin, 1999.
- Vilsmeier-Haack Mechanism: Meth-Cohn, O., & Stanforth, S. P.[4] "The Vilsmeier–Haack Reaction." [2][4][5] Comprehensive Organic Synthesis, 1991.
- Lithiation Selectivity: Begtrup, M., et al. "Lithiation of Pyrazoles: Regioselectivity and Application." Synthesis, 2003.

Need Custom Synthesis?

BenchChem offers custom synthesis for rare earth carbides and specific isotopic labeling.

Email: info@benchchem.com or [Request Quote Online](#).

Sources

- [1. researchgate.net \[researchgate.net\]](https://www.researchgate.net)
- [2. pdf.benchchem.com \[pdf.benchchem.com\]](https://pdf.benchchem.com)
- [3. Mild and Regioselective Bromination of Aromatic Compounds with N,N,N',N'-Tetrabromobenzene-1,3-disulfonylamide and Poly\(N-bromobenzene-1,3-disulfonylamide\) \[organic-chemistry.org\]](#)
- [4. Vilsmeier–Haack reaction - Wikipedia \[en.wikipedia.org\]](https://en.wikipedia.org)
- [5. Vilsmeier-Haack Reaction \(Chapter 112\) - Name Reactions in Organic Synthesis \[cambridge.org\]](#)
- To cite this document: BenchChem. [Strategic Functionalization of 1-Isopropyl-3-Methylpyrazole: A Modular C4-Targeting Guide]. BenchChem, [2026]. [Online PDF]. Available at: [<https://www.benchchem.com/product/b13454077/docs#strategic-functionalization-of-1-isopropyl-3-methylpyrazole-a-modular-c4-targeting-guide>]

Disclaimer & Data Validity:

The information provided in this document is for Research Use Only (RUO) and is strictly not intended for diagnostic or therapeutic procedures. While BenchChem strives to provide accurate protocols, we make no warranties, express or implied, regarding the fitness of this product for every specific experimental setup.

Technical Support: The protocols provided are for reference purposes. Unsure if this reagent suits your experiment?

Need Industrial/Bulk Grade? [Request Custom Synthesis Quote](#)

BenchChem

Our mission is to be the trusted global source of essential and advanced chemicals, empowering scientists and researchers to drive progress in science and industry.

Contact

Address: 3281 E Guasti Rd

Ontario, CA 91761, United States

Phone: (601) 213-4426

Email: info@benchchem.com

[Contact our Ph.D. Support Team for a compatibility check](#)