

Technical Support Center: Overcoming Solubility Issues of Phosphonate Compounds

Author: BenchChem Technical Support Team. **Date:** May 2026

Compound of Interest

Compound Name: *Diethyl (pyrrolidin-1-ylmethyl)phosphonate*

CAS No.: *51868-96-3*

Cat. No.: *B1345537*

[Get Quote](#)

Welcome to the technical support center for researchers, scientists, and drug development professionals. This guide is designed to provide in-depth, practical solutions to the common and complex solubility challenges encountered when working with phosphonate compounds. Drawing from established scientific principles and field-proven experience, this resource offers a series of troubleshooting guides and frequently asked questions to help you navigate your experiments successfully.

Frequently Asked Questions (FAQs)

This section addresses the most common initial questions researchers face when working with phosphonates.

Q1: Why are my phosphonate compounds so poorly soluble in aqueous solutions?

A: The solubility challenges of phosphonate compounds stem from several key physicochemical properties:

- **High Polarity and Charge:** The phosphonic acid group ($-\text{PO}(\text{OH})_2$) is highly polar and can be ionized. At neutral pH, it typically carries a negative charge, making phosphonates highly water-soluble. However, the corresponding neutral phosphonic acids are often only sparingly soluble.^{[1][2]}
- **Strong Crystal Lattice Energy:** Phosphonic acids are excellent hydrogen bond donors and acceptors. This allows them to form highly ordered, stable crystal lattices that are difficult to disrupt with solvent molecules, leading to low solubility.
- **Divalent Cation Chelation:** Phosphonates are powerful chelating agents for divalent and trivalent metal ions, such as Ca^{2+} and Mg^{2+} .^{[3][4]} If these ions are present in your buffer or water source, they can form highly insoluble metal-phosphonate precipitates.^{[5][6]}
- **pH-Dependent Ionization:** Phosphonic acids are di- or polyprotic acids, meaning they have multiple pKa values. Their charge state, and therefore their solubility, is highly dependent on the pH of the solution.^[7] The first pKa is typically around 2, with the second around 7, meaning small shifts in pH can dramatically alter the ionization state and solubility.^{[8][9][10]}

Q2: My phosphonate compound precipitated out of my buffer. What is the first thing I should check?

A: When a phosphonate precipitates, the two most immediate factors to investigate are pH and the presence of divalent cations.

- **Verify the pH:** A small, unintended shift in the buffer's pH can cause a phosphonate to cross a pKa threshold, leading to protonation and a significant drop in solubility. Measure the pH of your final solution.
- **Check for Divalent Cations:** Ensure your water source is high-purity (e.g., Type I, double-distilled) and free of contaminating metal ions.^[11] If your buffer contains intentionally added Ca^{2+} or Mg^{2+} , precipitation is highly likely.^[6]

Troubleshooting Guides

This section provides detailed, step-by-step guidance for systematically addressing and resolving specific solubility problems.

Issue 1: My phosphonate compound has low intrinsic solubility in my desired aqueous buffer.

When initial attempts to dissolve your compound fail, a systematic approach is required to identify an effective solubilization strategy.

The ionization state of a phosphonate is a primary driver of its aqueous solubility. By adjusting the pH, you can shift the equilibrium towards the more soluble, ionized form.

Causality: The phosphonic acid group has two key pKa values, typically $pK_{a1} \approx 2$ and $pK_{a2} \approx 7$. [8][12] Below pK_{a1} , the compound is neutral and often least soluble. Between pK_{a1} and pK_{a2} , it is monoanionic. Above pK_{a2} , it becomes dianionic, which is typically the most soluble form. Adjusting the pH to at least one to two units above the highest pKa will maximize ionization and solubility.

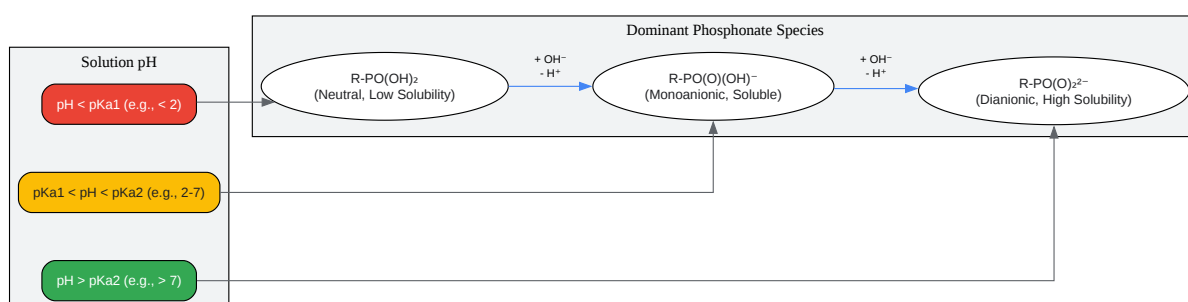

[Click to download full resolution via product page](#)

Caption: pH effect on phosphonate ionization and solubility.

Experimental Protocol: pH-Solubility Profiling

- Prepare Buffers: Create a series of buffers with overlapping ranges spanning from pH 2 to 10 (e.g., citrate, phosphate, borate).
- Add Compound: Add an excess amount of your solid phosphonate compound to a small volume (e.g., 1 mL) of each buffer in separate vials. Ensure undissolved solid is clearly visible.
- Equilibrate: Tightly cap the vials and shake or rotate them at a constant temperature (e.g., 25°C or 37°C) for 24-48 hours to ensure equilibrium is reached. This is the basis of the "shake-flask" method, considered the gold standard for thermodynamic solubility measurement.[\[13\]](#)
- Separate Solid: Centrifuge the samples at high speed (e.g., >10,000 x g) or filter through a 0.22 µm syringe filter to separate the undissolved solid from the saturated supernatant.
- Quantify: Carefully take an aliquot of the clear supernatant and dilute it into a suitable mobile phase. Quantify the concentration of the dissolved compound using a validated analytical method like HPLC-UV or LC-MS.[\[14\]](#)
- Analyze: Plot the measured solubility (e.g., in µg/mL or mM) against the pH of each buffer to determine the optimal pH range for your experiments.

If pH adjustment is not feasible or sufficient, the use of water-miscible organic solvents can enhance solubility.[\[15\]](#)

Causality: Co-solvents work by reducing the overall polarity of the aqueous solvent system.[\[16\]](#) This lessens the energy required to break the strong hydrogen bonds in the phosphonate's crystal lattice, thereby favoring dissolution.

Common Co-solvents for Preclinical Formulations:

- Polyethylene Glycol (PEG 300, PEG 400)
- Propylene Glycol (PG)
- Ethanol

- Glycerin
- Dimethyl Sulfoxide (DMSO)[17]
- N-methyl-2-pyrrolidone (NMP)[15]

Experimental Protocol: Co-solvent Screening

- **Select Co-solvents:** Choose a panel of 3-4 pharmaceutically acceptable co-solvents.
- **Prepare Blends:** At the optimal pH identified previously, prepare a series of aqueous buffer/co-solvent blends (e.g., 5%, 10%, 20%, 40% v/v co-solvent).
- **Measure Solubility:** Using the shake-flask method described above, determine the equilibrium solubility of your compound in each blend.
- **Evaluate:** Compare the solubility enhancement for each co-solvent. Be mindful that high concentrations of organic solvents can sometimes cause buffer salts (especially phosphate) to precipitate.[18][19]

Technique	Mechanism	Typical Fold Increase	Pros	Cons
pH Adjustment	Increases ionization of the phosphonate group.	10 - 1,000x	Simple, cost-effective, highly effective for ionizable compounds.	Limited by the pH constraints of the biological assay or formulation stability.
Co-solvents	Reduces solvent polarity, disrupting the crystal lattice.[16]	2 - 100x	Easy to screen multiple solvents; can be combined with pH adjustment.[20]	Potential for co-solvent to interfere with biological activity; toxicity at high concentrations. [16]
Salt Formation	Alters crystal packing and lattice energy, improving dissolution.[21]	Highly Variable	Can significantly improve solubility and stability; creates a new chemical entity with distinct properties.	Requires synthesis and characterization; not all compounds form stable, soluble salts.
Complexation	Encapsulates the hydrophobic parts of the molecule in a hydrophilic shell. [22]	5 - 500x	Masks poor solubility; can improve stability. [23]	Requires specific host-guest geometry; can be expensive; potential for competitive displacement.

Issue 2: My phosphonate precipitates when mixed with other formulation components or during storage.

Precipitation after initial dissolution is often caused by incompatibility or instability.

Creating a salt form of the phosphonate can be a robust strategy to overcome fundamental solubility and stability issues.[24]

Causality: Converting the phosphonic acid to a salt (e.g., sodium or potassium salt) disrupts the highly ordered crystal lattice of the acid form.[21] This change in the solid state often leads to a significant increase in aqueous solubility and dissolution rate. Phosphonate salts are generally much more water-soluble than their corresponding acid forms.[2][3]

Workflow for Salt Feasibility Assessment:

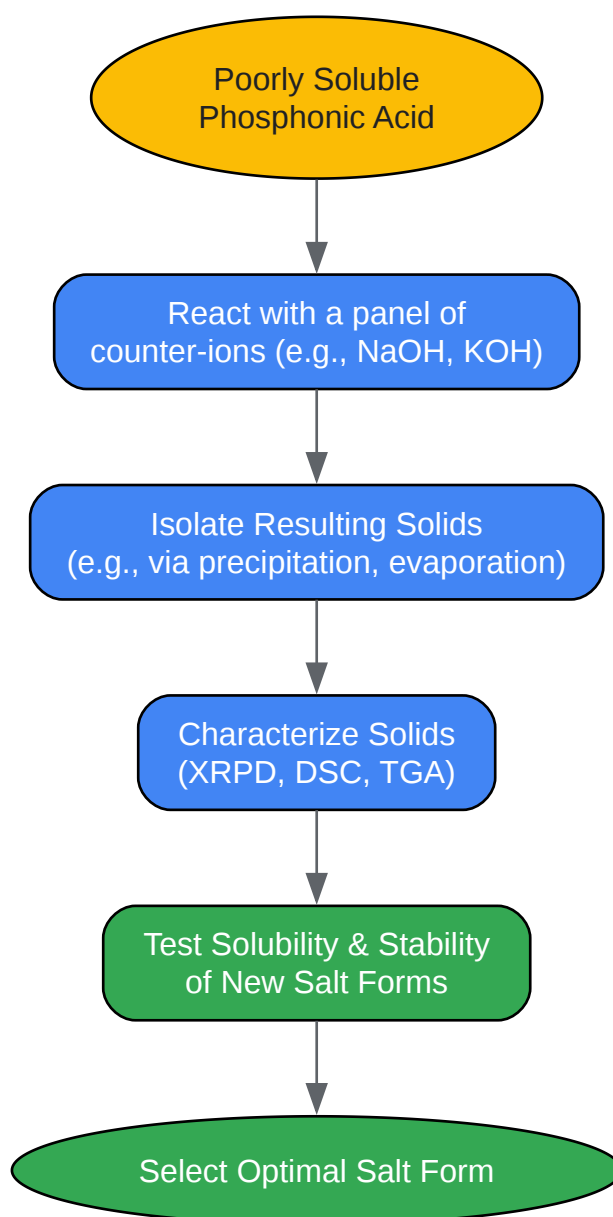

[Click to download full resolution via product page](#)

Caption: Workflow for phosphonate salt form screening.

Cyclodextrins are cyclic oligosaccharides that can encapsulate poorly soluble guest molecules, enhancing their apparent solubility.[\[22\]](#)

Causality: Cyclodextrins have a hydrophilic exterior and a hydrophobic inner cavity.[\[23\]](#) If the phosphonate compound has a non-polar region, it can be encapsulated within the cyclodextrin's cavity. The resulting "inclusion complex" has the hydrophilic properties of the cyclodextrin, rendering it much more soluble in water.[\[25\]](#)[\[26\]](#) Phosphorylated cyclodextrins have also been developed, which show enhanced solubility and solubilizing effects.[\[27\]](#)[\[28\]](#)

Experimental Protocol: Cyclodextrin Feasibility Study

- **Select Cyclodextrins:** Screen common cyclodextrins like Hydroxypropyl- β -Cyclodextrin (HP- β -CD) and Sulfobutylether- β -Cyclodextrin (SBE- β -CD).
- **Prepare Solutions:** Create a series of aqueous solutions with increasing concentrations of the cyclodextrin (e.g., 0, 2, 5, 10, 20% w/v).
- **Determine Phase Solubility:** Add an excess of the phosphonate compound to each solution and determine the compound's solubility using the shake-flask method.
- **Plot and Analyze:** Plot the concentration of the dissolved phosphonate against the concentration of the cyclodextrin. A linear increase (an AL-type diagram) indicates the formation of a soluble 1:1 complex and allows for the calculation of the binding constant.

References

- Ataman Kimya. (n.d.). PHOSPHONATES. Retrieved from [\[Link\]](#)
- Chemeurope.com. (n.d.). Phosphonate. Retrieved from [\[Link\]](#)
- Franz, R. G. (2001). Comparisons of pKa and log P values of some carboxylic and phosphonic acids: Synthesis and measurement. AAPS PharmSci, 3(2), E10. [\[Link\]](#)
- Improved Pharma. (2021, February 14). Solubility and Dissolution with HPLC or UV-Vis Detection. Retrieved from [\[Link\]](#)

- K-meta. (2025). Co-solvent: Significance and symbolism. Retrieved from [\[Link\]](#)
- Nema, S., & Washkuhn, R. J. (Eds.). (2010).
- PubMed Central (PMC). (2022). Bioavailability Enhancement Techniques for Poorly Aqueous Soluble Drugs and Therapeutics. National Center for Biotechnology Information. Retrieved from [\[Link\]](#)
- ResearchGate. (2015). Solubility and Inhibition Efficiency of Phosphonate Scale Inhibitor_Calcium_Magnesium Complexes for Application in a Precipitation-Squeeze Treatment. Retrieved from [\[Link\]](#)
- ResearchGate. (2019). A review of methods for solubility determination in biopharmaceutical drug characterisation. Retrieved from [\[Link\]](#)
- ResearchGate. (n.d.). pKa values for the first and second ionisation of phosphonic acids. Retrieved from [\[Link\]](#)
- Solubility of Things. (n.d.). Phosphonoacetate. Retrieved from [\[Link\]](#)
- Various Authors. (2012, February 24). What are the chances of precipitation in column while using buffers as mobile phase? ResearchGate. Retrieved from [\[Link\]](#)
- Various Authors. (2018, June 19). Why the PBS buffer precipitate? ResearchGate. Retrieved from [\[Link\]](#)
- Various Authors. (2022, March 23). Buffer keeps precipitating. Any advice why? Reddit. Retrieved from [\[Link\]](#)
- Wasser 3.0. (n.d.). Phosphonates. Retrieved from [\[Link\]](#)
- Wikipedia. (n.d.). Phosphonate. Retrieved from [\[Link\]](#)
- Wikipedia. (n.d.). Phosphoric acid. Retrieved from [\[Link\]](#)
- YouTube. (2015, November 11). Phosphonate. Retrieved from [\[Link\]](#)

Need Custom Synthesis?

BenchChem offers custom synthesis for rare earth carbides and specific isotopic labeling.

Email: info@benchchem.com or [Request Quote Online](#).

Sources

- [1. youtube.com](https://www.youtube.com) [[youtube.com](https://www.youtube.com)]
- [2. Phosphonate](https://www.chemurope.com) [[chemurope.com](https://www.chemurope.com)]
- [3. Phosphonate - Wikipedia](https://en.wikipedia.org) [en.wikipedia.org]
- [4. evo-chemical.com](https://www.evo-chemical.com) [[evo-chemical.com](https://www.evo-chemical.com)]
- [5. researchgate.net](https://www.researchgate.net) [[researchgate.net](https://www.researchgate.net)]
- [6. reddit.com](https://www.reddit.com) [[reddit.com](https://www.reddit.com)]
- [7. Phosphonates - Wasser 3.0](https://www.wasserdreinull.de) [[wasserdreinull.de](https://www.wasserdreinull.de)]
- [8. Comparisons of pKa and log P values of some carboxylic and phosphonic acids: synthesis and measurement - PubMed](https://pubmed.ncbi.nlm.nih.gov) [pubmed.ncbi.nlm.nih.gov]
- [9. Phosphoric acid - Wikipedia](https://en.wikipedia.org) [en.wikipedia.org]
- [10. Phosphoric Acid](https://www.commonorganicchemistry.com) [[commonorganicchemistry.com](https://www.commonorganicchemistry.com)]
- [11. researchgate.net](https://www.researchgate.net) [[researchgate.net](https://www.researchgate.net)]
- [12. sci-hub.se](https://www.sci-hub.se) [[sci-hub.se](https://www.sci-hub.se)]
- [13. researchgate.net](https://www.researchgate.net) [[researchgate.net](https://www.researchgate.net)]
- [14. improvedpharma.com](https://www.improvedpharma.com) [[improvedpharma.com](https://www.improvedpharma.com)]
- [15. Enhancing the Bioavailability of Poorly Soluble Compounds: Strategies for Formulation Optimization in Preclinical Studies - WuXi AppTec DMPK](https://www.dmpk.wuxiapptec.com) [[dmpk.wuxiapptec.com](https://www.dmpk.wuxiapptec.com)]
- [16. Co-solvency and anti-solvent method for the solubility enhancement](https://www.wisdomlib.org) [[wisdomlib.org](https://www.wisdomlib.org)]
- [17. Co-solvent: Significance and symbolism](https://www.wisdomlib.org) [[wisdomlib.org](https://www.wisdomlib.org)]
- [18. HPLC Troubleshooting: Precipitation of Buffers in Gradient Elution Mode](https://www.thermofisher.com) [[thermofisher.com](https://www.thermofisher.com)]
- [19. researchgate.net](https://www.researchgate.net) [[researchgate.net](https://www.researchgate.net)]

- 20. Co-solvent solubilization of some poorly-soluble antidiabetic drugs - PubMed [pubmed.ncbi.nlm.nih.gov]
- 21. Bioavailability Enhancement Techniques for Poorly Aqueous Soluble Drugs and Therapeutics - PMC [pmc.ncbi.nlm.nih.gov]
- 22. oatext.com [oatext.com]
- 23. oatext.com [oatext.com]
- 24. merckmillipore.com [merckmillipore.com]
- 25. Computational Insights into Cyclodextrin Inclusion Complexes with the Organophosphorus Flame Retardant DOPO - PMC [pmc.ncbi.nlm.nih.gov]
- 26. researchgate.net [researchgate.net]
- 27. cyclolab.hu [cyclolab.hu]
- 28. Novel phosphorus-containing cyclodextrin polymers and their affinity for calcium cations and hydroxyapatite - PubMed [pubmed.ncbi.nlm.nih.gov]
- To cite this document: BenchChem. [Technical Support Center: Overcoming Solubility Issues of Phosphonate Compounds]. BenchChem, [2026]. [Online PDF]. Available at: [<https://www.benchchem.com/product/b1345537/docs#technical-support-center-overcoming-solubility-issues-of-phosphonate-compounds>]

Disclaimer & Data Validity:

The information provided in this document is for Research Use Only (RUO) and is strictly not intended for diagnostic or therapeutic procedures. While BenchChem strives to provide accurate protocols, we make no warranties, express or implied, regarding the fitness of this product for every specific experimental setup.

Technical Support: The protocols provided are for reference purposes. Unsure if this reagent suits your experiment?

Need Industrial/Bulk Grade? [Request Custom Synthesis Quote](#)

BenchChem

Our mission is to be the trusted global source of essential and advanced chemicals, empowering scientists and researchers to drive progress in science and industry.

Contact

Address: 3281 E Guasti Rd

Ontario, CA 91761, United States

Phone: (601) 213-4426

Email: info@benchchem.com

[Contact our Ph.D. Support Team for a compatibility check](#)