

Technical Guide: Biological Activity & Evaluation of Substituted Pyridines

Author: BenchChem Technical Support Team. **Date:** May 2026

Compound of Interest

Compound Name: 2-(Bromomethyl)-6-(pyrrolidin-1-yl)pyridine
CAS No.: 869901-04-2
Cat. No.: B1345289

[Get Quote](#)

Executive Summary

The pyridine moiety (

) is not merely a structural subunit; it is a "privileged scaffold" in medicinal chemistry, present in over 14% of all U.S. FDA-approved drugs. Its ubiquity stems from its physicochemical versatility: the nitrogen atom acts as a hydrogen bond acceptor (pKa ~5.2), modulating solubility and target affinity, while the electron-deficient ring system allows for diverse metabolic stability profiles compared to benzene isosteres.

This guide provides a technical deep-dive into the structure-activity relationships (SAR), therapeutic mechanisms, and validation protocols for substituted pyridines. It is designed for medicinal chemists and pharmacologists seeking to optimize pyridine-based leads in oncology, infectious disease, and CNS therapeutics.

Part 1: Chemical Foundation & SAR Logic

The biological activity of substituted pyridines is governed by the electronic perturbation of the heterocyclic ring. The nitrogen atom pulls electron density, making the C2, C4, and C6 positions electron-deficient (susceptible to nucleophilic attack) and the C3/C5 positions relatively electron-rich (susceptible to electrophilic attack).

Electronic Modulation & Binding Affinity

- The "Hinge Binder" Effect: In kinase inhibitors, the pyridine nitrogen often serves as a critical H-bond acceptor, interacting with the backbone NH of the kinase hinge region (e.g., in Sorafenib or Vemurafenib).
- Metabolic Blocking: Substitution with electron-withdrawing groups (EWGs) like

or

at metabolically labile positions (C3/C5) blocks cytochrome P450 oxidation, extending half-life (

).
- Basicity Tuning: Introducing amino groups at C2/C6 increases basicity, enhancing solubility in acidic media, whereas electron-withdrawing groups reduce basicity, improving membrane permeability (LogP).

Visualization: SAR Decision Matrix

The following diagram illustrates the logical flow for optimizing pyridine substitutions based on desired biological outcomes.

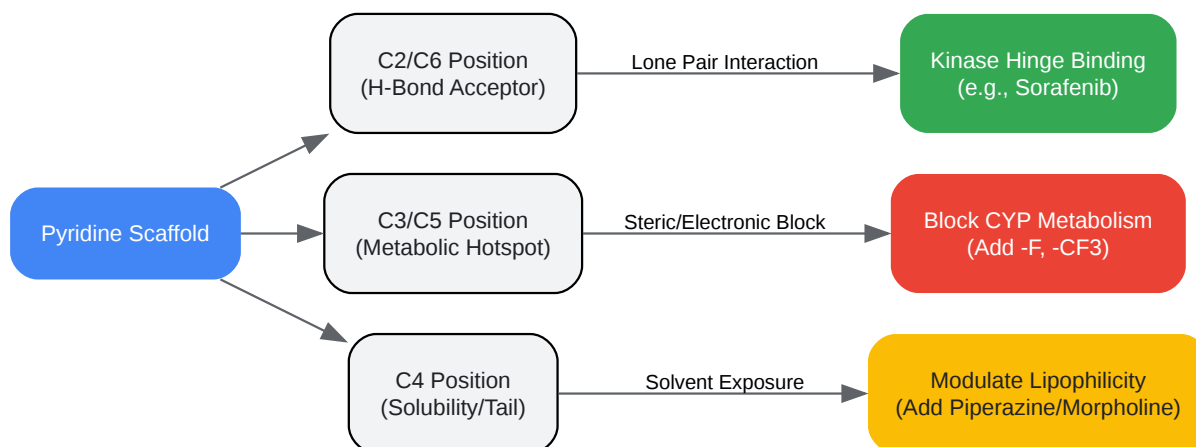

[Click to download full resolution via product page](#)

Figure 1: Strategic substitution logic for pyridine scaffold optimization. The C2 position is critical for target engagement, while C3/C5 modulation drives pharmacokinetic stability.

Part 2: Therapeutic Vectors & Mechanisms

Oncology: Kinase Inhibition

Substituted pyridines, particularly fused systems like pyrazolo[3,4-b]pyridines and imidazo[1,2-a]pyridines, are dominant in oncology.

- Mechanism: These scaffolds function as ATP-competitive inhibitors. The pyridine nitrogen mimics the N1 or N3 of the adenine ring of ATP, anchoring the molecule in the kinase active site.
- Case Study: Selpercatinib (RET inhibitor).^[1] The pyridine moiety forms a crucial water-mediated hydrogen bond network, stabilizing the drug in the ATP pocket of RET-mutant kinases.

Infectious Disease: Antitubercular Agents^[2]^[3]

- Mechanism: Isoniazid (isonicotinylhydrazide) is a prodrug activated by the bacterial catalase-peroxidase enzyme KatG. The pyridine radical generated reacts with NAD⁺ to form an adduct that inhibits InhA, blocking mycolic acid synthesis.

- Recent Advances: 2,4-disubstituted pyridines have shown efficacy against multidrug-resistant (MDR) *Staphylococcus aureus* by disrupting cell membrane potential.

Comparative Data: FDA-Approved Pyridine Drugs

The table below highlights how the pyridine scaffold is utilized across different indications.

| Drug Name | Indication | Target | Role of Pyridine Scaffold |
|--------------|----------------------|---------------------------------------|---|
| Sorafenib | Renal Cell Carcinoma | VEGFR/PDGFR | Hinge binder (H-bond acceptor) |
| Isoniazid | Tuberculosis | InhA (Enoyl-ACP reductase) | Prodrug carrier / Radical precursor |
| Vismodegib | Basal Cell Carcinoma | Hedgehog Pathway (SMO) | Conformational lock & Hydrophobic interaction |
| Abemaciclib | Breast Cancer | CDK4/6 | Specificity determinant for ATP pocket |
| Esomeprazole | GERD | H ⁺ /K ⁺ ATPase | Activated to sulfenamide; binds Cys residues |

Part 3: Experimental Protocols for Evaluation

To ensure data integrity (Trustworthiness), the following protocols utilize standard controls and self-validating steps.

Protocol A: In Vitro Cytotoxicity Evaluation (MTT Assay)

Objective: Determine the IC₅₀ of pyridine derivatives against cancer cell lines (e.g., MCF-7, HepG2).

Reagents:

- MTT Reagent: 3-(4,5-dimethylthiazol-2-yl)-2,5-diphenyltetrazolium bromide (5 mg/mL in PBS).
- Solubilization Buffer: DMSO or SDS-HCl.

Workflow:

- Seeding: Plate cells at

cells/well in 96-well plates. Incubate for 24h at 37°C/5% CO₂.
- Treatment: Add test compounds (dissolved in DMSO, final concentration <0.1%) in serial dilutions (e.g., 0.1 μM to 100 μM).
 - Control: Vehicle (DMSO) only.
 - Positive Control: Doxorubicin or Sorafenib.[\[2\]](#)
- Incubation: Incubate for 48h or 72h.
- MTT Addition: Add 20 μL MTT reagent per well. Incubate for 4h (purple formazan crystals form).
- Solubilization: Aspirate media carefully. Add 100 μL DMSO to dissolve crystals.
- Quantification: Measure absorbance at 570 nm (reference 630 nm).
- Calculation:
 - Validation Check: The Z-factor of the assay must be > 0.5 for statistical reliability.

Protocol B: Kinase Inhibition Assay (FRET-based)

Objective: Quantify binding affinity (

or

) against specific kinases (e.g., VEGFR-2).

Workflow Visualization:

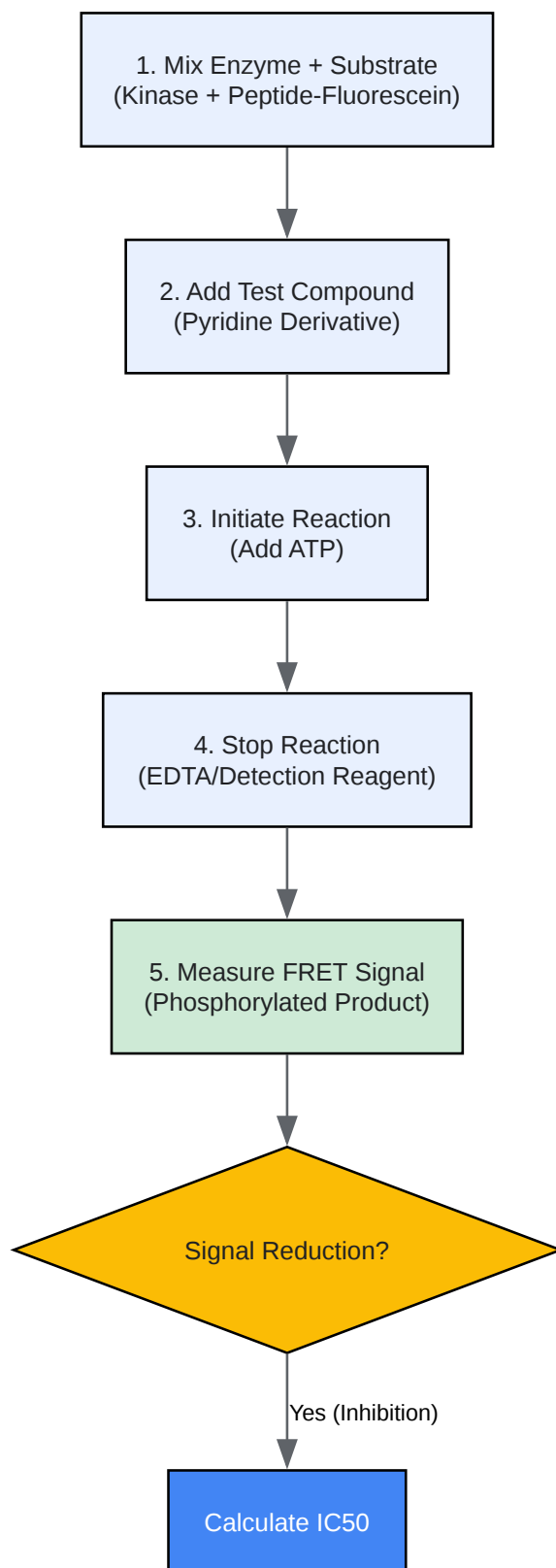

[Click to download full resolution via product page](#)

Figure 2: FRET-based kinase assay workflow. A reduction in FRET signal correlates with successful competitive inhibition by the test compound.

Part 4: Synthesis & Validation Pathway

Scientific integrity requires that biological data be supported by rigorous chemical characterization.

- Synthesis: Common routes include the Hantzsch pyridine synthesis or Suzuki-Miyaura coupling of halopyridines.
- Characterization (Required):
 - ¹H / ¹³C NMR: Confirm substitution patterns (e.g., splitting of pyridine protons).
 - HRMS: Confirm elemental composition.
 - Purity: HPLC purity must be >95% before biological testing to rule out false positives from impurities.

Case Study: Pyrazolo[3,4-b]pyridine Derivatives

Recent studies (2020-2024) have focused on 1,3,4-trisubstituted pyrazolo[3,4-b]pyridines.

- Design: C4-position substituted with an aryl ring (via Suzuki coupling) to target the hydrophobic pocket.
- Outcome: Derivatives showed nanomolar activity against MCF-7 cells (), outperforming standard chemotherapy agents in specific resistant lines.

References

- FDA-Approved Drugs Containing Pyridine Scaffolds. ResearchGate. Retrieved from
- A decade of pyridine-containing heterocycles in US FDA approved drugs (2014–2023). RSC Advances. Retrieved from

- Pyrazolopyridine-based kinase inhibitors for anti-cancer targeted therapy. RSC Medicinal Chemistry. Retrieved from
- Design, synthesis, and SAR of novel imidazo[1,2-a] pyridine derivatives as Nek2 inhibitors. Bioorganic & Medicinal Chemistry. Retrieved from
- Synthesis and Structure–Activity Relationship Studies of Novel Pyrazolopyridine Derivatives as Inhibitors of Enterovirus Replication. Journal of Medicinal Chemistry. Retrieved from
- Pyridine-Ureas as Potential Anticancer Agents: Synthesis and In Vitro Biological Evaluation. Molecules. Retrieved from

Need Custom Synthesis?

BenchChem offers custom synthesis for rare earth carbides and specific isotopic labeling.

Email: info@benchchem.com or [Request Quote Online](#).

Sources

- [1. Pyrazolopyridine-based kinase inhibitors for anti-cancer targeted therapy - PMC \[pmc.ncbi.nlm.nih.gov\]](#)
- [2. mdpi.com \[mdpi.com\]](#)
- To cite this document: BenchChem. [Technical Guide: Biological Activity & Evaluation of Substituted Pyridines]. BenchChem, [2026]. [Online PDF]. Available at: [\[https://www.benchchem.com/product/b1345289/docs#technical-guide-biological-activity-evaluation-of-substituted-pyridines\]](https://www.benchchem.com/product/b1345289/docs#technical-guide-biological-activity-evaluation-of-substituted-pyridines)

Disclaimer & Data Validity:

The information provided in this document is for Research Use Only (RUO) and is strictly not intended for diagnostic or therapeutic procedures. While BenchChem strives to provide accurate protocols, we make no warranties, express or implied, regarding the fitness of this product for every specific experimental setup.

Technical Support: The protocols provided are for reference purposes. Unsure if this reagent suits your experiment?

Need Industrial/Bulk Grade? [Request Custom Synthesis Quote](#)

BenchChem

Our mission is to be the trusted global source of essential and advanced chemicals, empowering scientists and researchers to drive progress in science and industry.

Contact

Address: 3281 E Guasti Rd
Ontario, CA 91761, United States
Phone: (601) 213-4426
Email: info@benchchem.com

[Contact our Ph.D. Support Team for a compatibility check](#)