

# Application Notes and Protocols for Evaluating Isothiazolopyridine Cytotoxicity

**Author:** BenchChem Technical Support Team. **Date:** May 2026

## Compound of Interest

Compound Name: *4,6-Dimethylisothiazolo[5,4-b]pyridin-3(2H)-one*

CAS No.: 60750-75-6

Cat. No.: B1345993

[Get Quote](#)

**Authored by: a Senior Application Scientist**

## Abstract

This document provides a comprehensive guide for researchers, scientists, and drug development professionals on designing and executing robust experimental protocols to evaluate the cytotoxicity of novel isothiazolopyridine compounds. Isothiazolopyridines are a class of heterocyclic compounds with a wide range of biological activities, including potential anticancer properties.<sup>[1]</sup> A thorough understanding of their cytotoxic profile is paramount for their development as therapeutic agents. This guide emphasizes the causality behind experimental choices, outlines self-validating protocols, and is grounded in authoritative scientific literature.

## Introduction: The Rationale for Cytotoxicity Testing of Isothiazolopyridines

Isothiazolopyridines have emerged as a promising scaffold in medicinal chemistry due to their diverse biological activities, which include antibacterial, anti-inflammatory, and potential antineoplastic effects.[1][2][3] The cytotoxic potential of these compounds is a double-edged sword: it is a desired attribute for anticancer agents but an adverse effect for other therapeutic applications.[4] Therefore, a rigorous and multi-faceted approach to cytotoxicity testing is essential to characterize the therapeutic window and potential liabilities of new isothiazolopyridine derivatives.

This guide will walk you through a tiered strategy for cytotoxicity assessment, from initial screening to more detailed mechanistic studies. We will cover key assays that probe different cellular processes, including metabolic activity, membrane integrity, and apoptosis.

## Foundational Experimental Design: Setting the Stage for Reliable Data

A well-designed experiment is the bedrock of trustworthy results. Before embarking on specific assays, several key factors must be considered to ensure the data generated is both accurate and relevant.

### Cell Line Selection: The Biological Context Matters

The choice of cell line is critical and should be guided by the therapeutic goal of the isothiazolopyridine compound.[5]

- For Anticancer Screening: A panel of cancer cell lines representing different tumor types (e.g., breast, lung, colon) should be utilized.[6] This approach helps to identify compounds with broad-spectrum activity or those with selectivity towards specific cancer types.
- For General Toxicity Assessment: Non-cancerous cell lines are essential to evaluate the compound's toxicity to normal tissues.[7] Commonly used normal cell lines include human dermal fibroblasts (HDFs) or cell lines derived from organs that are common sites of drug-induced toxicity, such as the liver (HepG2) or kidney (HEK293).[5]

### Dose-Response and Time-Course Studies: Understanding the Dynamics of Cytotoxicity

Cytotoxicity is both dose- and time-dependent.[8] A single-point assay can be misleading. Therefore, it is crucial to perform:

- **Dose-Response Studies:** Cells should be exposed to a range of concentrations of the isothiazolopyridine compound. This typically involves a serial dilution, often logarithmic, to cover a wide concentration range.[9] This allows for the determination of the half-maximal inhibitory concentration (IC50), a key parameter for quantifying a compound's potency.[10]
- **Time-Course Studies:** The effect of the compound should be assessed at different time points (e.g., 24, 48, and 72 hours) to understand the kinetics of the cytotoxic response.[11]

## Essential Controls: The Foundation of a Self-Validating Assay

Every cytotoxicity assay must include a set of controls to ensure the validity of the results.[11]

- **Negative Control (Vehicle Control):** Cells treated with the vehicle (the solvent used to dissolve the isothiazolopyridine, e.g., DMSO) at the same concentration used for the test compounds. This control accounts for any potential toxicity of the solvent itself.
- **Positive Control:** A known cytotoxic agent (e.g., doxorubicin, staurosporine) to confirm that the assay is performing as expected and the cells are responsive to cytotoxic stimuli.
- **Untreated Control:** Cells cultured in medium alone to represent 100% viability.
- **Blank Control (Medium Only):** Wells containing only cell culture medium to determine the background absorbance or fluorescence.

## Tier 1: Primary Cytotoxicity Screening - Assessing Cell Viability

The initial step in cytotoxicity profiling is to determine the overall effect of the isothiazolopyridine on cell viability. The MTT assay is a widely used, robust, and cost-effective method for this purpose.[12]

## The MTT Assay: A Measure of Metabolic Activity

The MTT (3-(4,5-dimethylthiazol-2-yl)-2,5-diphenyltetrazolium bromide) assay is a colorimetric assay that measures the metabolic activity of cells, which is an indicator of cell viability.[13] In viable cells, mitochondrial dehydrogenases reduce the yellow tetrazolium salt MTT to purple formazan crystals.[14] The amount of formazan produced is directly proportional to the number of living, metabolically active cells.[12]

#### Protocol 1: MTT Assay for Isothiazolopyridine Cytotoxicity

- Cell Seeding: Seed cells in a 96-well plate at a predetermined optimal density and allow them to adhere overnight.[12]
- Compound Treatment: The next day, treat the cells with a range of concentrations of the isothiazolopyridine compound and the appropriate controls.
- Incubation: Incubate the plate for the desired time period (e.g., 24, 48, or 72 hours) at 37°C in a humidified incubator with 5% CO<sub>2</sub>.
- MTT Addition: After incubation, add MTT solution to each well to a final concentration of 0.5 mg/mL and incubate for 2-4 hours at 37°C.[12][15]
- Formazan Solubilization: Carefully remove the medium and add a solubilizing agent (e.g., DMSO or a specialized solubilization buffer) to dissolve the formazan crystals.[12]
- Absorbance Measurement: Measure the absorbance of the resulting colored solution using a microplate reader at a wavelength of 570 nm.

## Data Presentation: Summarizing MTT Assay Results

| Compound                       | Concentration ( $\mu\text{M}$ ) | % Cell Viability (Mean $\pm$ SD) |
|--------------------------------|---------------------------------|----------------------------------|
| Isothiazolopyridine A          | 0.1                             | 98.5 $\pm$ 4.2                   |
| 1                              | 85.2 $\pm$ 5.1                  |                                  |
| 10                             | 52.1 $\pm$ 3.8                  |                                  |
| 50                             | 15.7 $\pm$ 2.5                  |                                  |
| 100                            | 5.3 $\pm$ 1.9                   |                                  |
| Doxorubicin (Positive Control) | 1                               | 45.6 $\pm$ 3.1                   |

This table presents hypothetical data for illustrative purposes.

## Tier 2: Differentiating Cytotoxicity Mechanisms - Membrane Integrity and Apoptosis

If an isothiazolopyridine shows significant cytotoxicity in the MTT assay, the next step is to investigate the mechanism of cell death. The two primary modes of cell death are necrosis and apoptosis.

### The Lactate Dehydrogenase (LDH) Assay: A Marker of Membrane Damage

The LDH assay is a colorimetric method used to quantify cell death by measuring the release of lactate dehydrogenase from cells with damaged plasma membranes, a hallmark of necrosis. [16] LDH is a stable cytosolic enzyme that is released into the cell culture medium upon membrane rupture. [17]

#### Protocol 2: LDH Cytotoxicity Assay

- Cell Seeding and Treatment: Follow the same initial steps as the MTT assay for cell seeding and compound treatment in a 96-well plate. [11]
- Sample Collection: After the desired incubation period, carefully collect a small aliquot of the cell culture supernatant from each well. [18]

- **LDH Reaction:** Transfer the supernatant to a new 96-well plate and add the LDH reaction mixture according to the manufacturer's instructions. This mixture typically contains lactate, NAD<sup>+</sup>, and a tetrazolium salt.[17]
- **Incubation:** Incubate the plate at room temperature for a specified time (usually 15-30 minutes), protected from light.
- **Absorbance Measurement:** Measure the absorbance of the generated formazan at the recommended wavelength (e.g., 490 nm).[17]

## Apoptosis Assays: Unraveling Programmed Cell Death

Apoptosis, or programmed cell death, is a highly regulated process that is often a desired outcome for anticancer drugs.[19][20] Several assays can detect the biochemical and morphological changes associated with apoptosis.

This flow cytometry-based assay is a gold standard for detecting apoptosis.[21]

- **Annexin V:** A protein that binds to phosphatidylserine (PS), a phospholipid that translocates from the inner to the outer leaflet of the plasma membrane during early apoptosis.
- **Propidium Iodide (PI):** A fluorescent dye that can only enter cells with compromised membranes, a characteristic of late apoptotic and necrotic cells.

This dual staining allows for the differentiation of:

- **Viable cells:** Annexin V-negative and PI-negative.
- **Early apoptotic cells:** Annexin V-positive and PI-negative.
- **Late apoptotic/necrotic cells:** Annexin V-positive and PI-positive.

Caspases are a family of proteases that play a central role in the execution of apoptosis.[21] Caspase-3 and Caspase-7 are key executioner caspases. Commercially available kits provide a luminogenic or fluorogenic substrate that is cleaved by active caspases, generating a measurable signal that is proportional to caspase activity.[22]

Protocol 3: Caspase-3/7 Activity Assay

- **Cell Seeding and Treatment:** Seed cells in a white-walled 96-well plate suitable for luminescence measurements and treat with the isothiazolopyridine compounds.
- **Reagent Addition:** After incubation, add the Caspase-Glo® 3/7 Reagent directly to the wells.
- **Incubation:** Incubate at room temperature for 1-2 hours.
- **Luminescence Measurement:** Measure the luminescence using a plate-reading luminometer.

## Data Analysis and Interpretation

Proper statistical analysis is crucial for drawing valid conclusions from cytotoxicity data.

- **IC50 Calculation:** For dose-response data, a non-linear regression analysis should be performed to determine the IC50 value.[\[9\]](#)
- **Statistical Significance:** For comparing treated groups to the vehicle control, an appropriate statistical test such as a one-way ANOVA followed by a post-hoc test (e.g., Dunnett's test) should be used.[\[23\]](#)[\[24\]](#) A p-value of less than 0.05 is typically considered statistically significant.[\[25\]](#)

## Visualizing Workflows and Pathways

Diagrams can provide a clear and concise overview of the experimental processes and underlying biological mechanisms.

Experimental Workflow for Isothiazolopyridine Cytotoxicity Testing

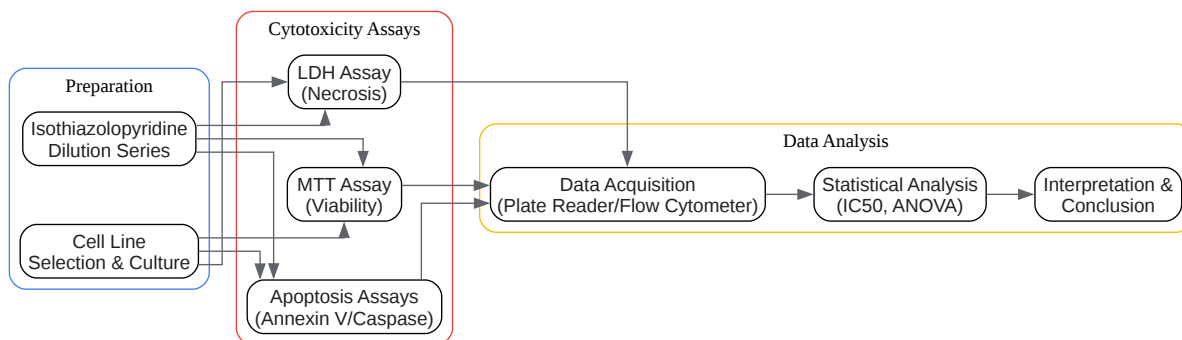

[Click to download full resolution via product page](#)

Caption: A streamlined workflow for assessing the cytotoxicity of isothiazolopyridines.

Mechanism of the MTT Assay

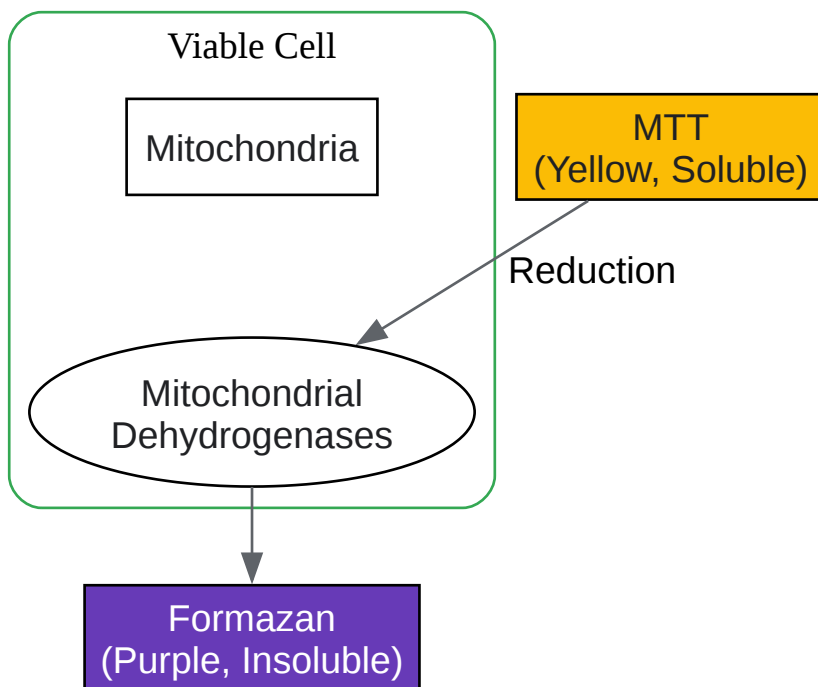

[Click to download full resolution via product page](#)

Caption: The enzymatic conversion of MTT to formazan in viable cells.

Decision Tree for Cytotoxicity Assay Selection

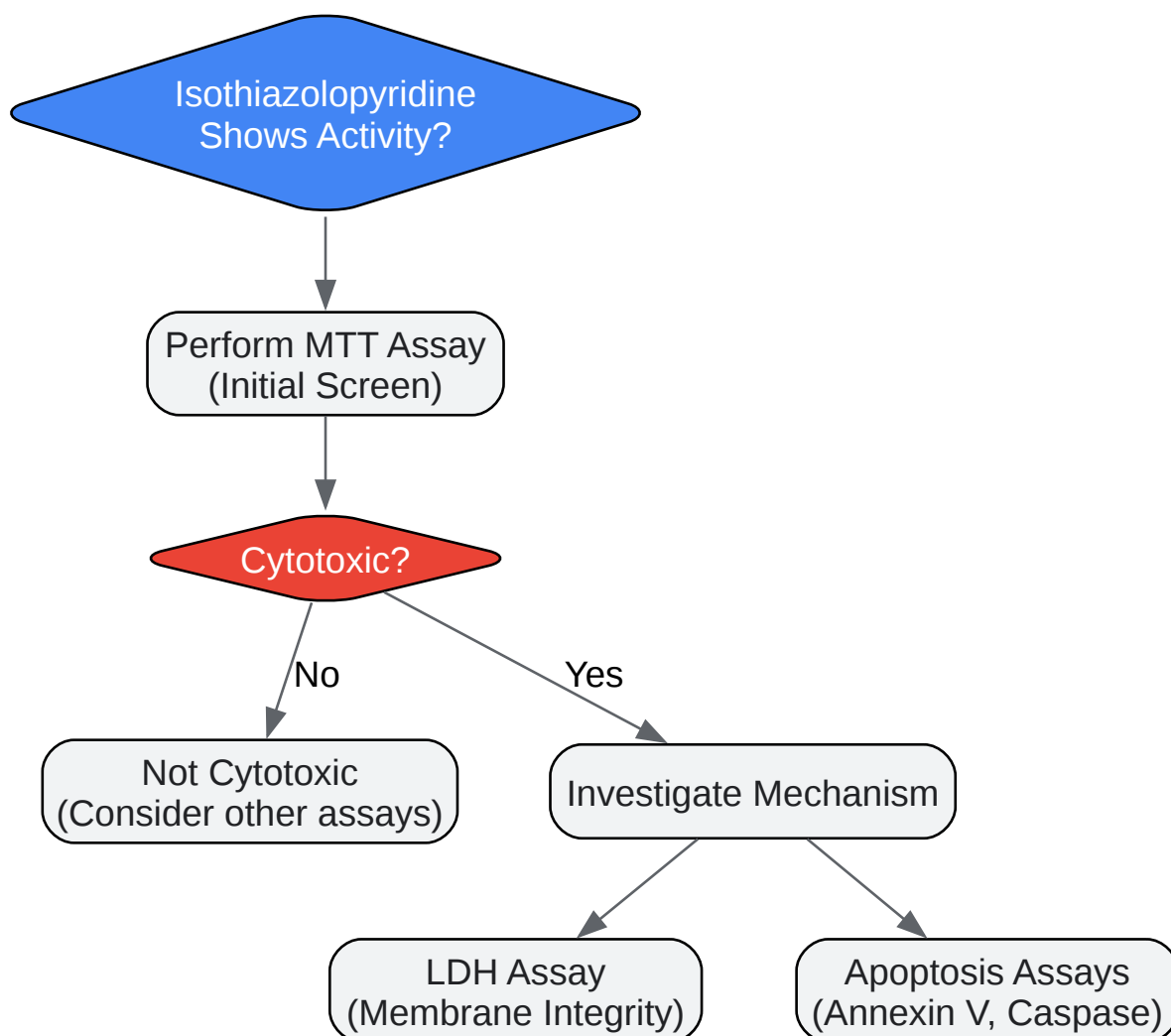

[Click to download full resolution via product page](#)

Caption: A decision-making guide for selecting appropriate cytotoxicity assays.

## References

- Springer Nature Experiments. (n.d.). Cytotoxicity MTT Assay Protocols and Methods. Retrieved from [[Link](#)]

- CLYTE Technologies. (2025, December 24). MTT Assay Protocol: Guide to Measuring Cell Viability & Proliferation. Retrieved from [\[Link\]](#)
- Wiles, J. A., Hashimoto, A., Thanassi, J. A., Cheng, J., Incarvito, C. D., Deshpande, M., Pucci, M. J., & Bradbury, B. J. (2006). Isothiazolopyridones: synthesis, structure, and biological activity of a new class of antibacterial agents. *Journal of medicinal chemistry*, 49(1), 39–42. [\[Link\]](#)
- Brunelle, J. K., & Zhang, B. (2010). Apoptosis assays for quantifying the bioactivity of anticancer drug products. *Drug resistance updates : reviews and commentaries in antimicrobial and anticancer chemotherapy*, 13(6), 172–179. [\[Link\]](#)
- Szafrański, K., Węglińska, M., Szafrański, W., & Demchuk, O. M. (2013). Synthesis of novel isothiazolopyridines and their in vitro evaluation against *Mycobacterium* and *Propionibacterium acnes*. *Bioorganic & medicinal chemistry letters*, 23(17), 4992–4996. [\[Link\]](#)
- National Center for Biotechnology Information. (2013). Assay Guidance Manual: Cell Viability Assays. Retrieved from [\[Link\]](#)
- Creative Diagnostics. (n.d.). Efficiently Evaluate the Effect of Drugs on Cell Apoptosis. Retrieved from [\[Link\]](#)
- G-Biosciences. (2020, January 7). The Role of LDH in Cellular Cytotoxicity. Retrieved from [\[Link\]](#)
- Tiaris Biosciences. (n.d.). LDH CYTOTOXICITY ASSAY KIT. Retrieved from [\[Link\]](#)
- ResearchGate. (2014, October 8). What is the best method/assay for the apoptosis mediated by anticancer drugs for routine drug screening application in cell culture? Retrieved from [\[Link\]](#)
- ResearchGate. (2023, May 6). What cell line should I choose for cytotoxicity assays? Retrieved from [\[Link\]](#)
- National Center for Biotechnology Information. (2019). Assay Guidance Manual: Cytotoxicity Assays: In Vitro Methods to Measure Dead Cells. Retrieved from [\[Link\]](#)

- MDPI. (n.d.). Advances in Cytotoxicity Testing: From In Vitro Assays to In Silico Models. Retrieved from [[Link](#)]
- BMG Labtech. (2025, August 5). Apoptosis – what assay should I use? Retrieved from [[Link](#)]
- science24.com. (2012, March 15). New isothiazolopyridines and their in vitro antibacterial activity. Retrieved from [[Link](#)]
- Pharma Now. (n.d.). Using 3D Cell Culture for Toxicity Testing: A Step-by-Step Framework. Retrieved from [[Link](#)]
- MDPI. (2026, January 18). Antitumor Activity of All-Trans Retinoic Acid and Curcumin-Loaded BSA Nanoparticles Against U87 Glioblastoma Cells. Retrieved from [[Link](#)]
- ResearchGate. (2021, April 28). What statistical analysis should I pursue with a study of cytotoxic effects using AT and MTT? Retrieved from [[Link](#)]
- Sasane, N. A., et al. (2024). Chapter 3: Isothiazoles: Synthetic Strategies and Pharmacological Applications.
- Frontiers. (n.d.). In vitro characterization of antimicrobial efficacy and cytotoxicity of polyvinylpyrrolidone-iodine, N-acetylcysteine, methylglyoxal, and N-chlorotaurine as alternative antimicrobials in treating bovine clinical endometritis. Retrieved from [[Link](#)]
- NorthEast BioLab. (n.d.). Cell Cytotoxicity Assay, Cell Toxicity Assay. Retrieved from [[Link](#)]
- Statistical Analysis: MTT-assay (cell viability test). (n.d.).
- Reddit. (2024, June 6). Which Statistical Test for Cytotoxicity Analysis with Multiple Concentrations: T-Test or ANOVA with Post Hoc? Retrieved from [[Link](#)]
- Literature review of dose-response analyses in toxicology. (n.d.). Retrieved from [[Link](#)]
- Hothorn, L. A., & Hitzfeld, S. (2023). Guidance for statistical design and analysis of toxicological dose-response experiments, based on a comprehensive literature review. Archives of toxicology, 97(8), 2095–2111. [[Link](#)]

- MDPI. (n.d.). Synthesis and Biological Activity Evaluation of Novel 5-Methyl-7-phenyl-3H-thiazolo[4,5-b]pyridin-2-ones. Retrieved from [\[Link\]](#)
- Taylor & Francis. (n.d.). Dose response – Knowledge and References. Retrieved from [\[Link\]](#)
- ToxTutor. (n.d.). The dose-response relationship. Retrieved from [\[Link\]](#)
- National Center for Biotechnology Information. (n.d.). Synthesis and cytotoxic evaluation of some novel 3-[2-(2-phenyl-thiazol-4-yl)-ethyl]-3H-pyrido[2,3-d]pyrimidin-4-one derivatives. Retrieved from [\[Link\]](#)
- PubMed. (n.d.). [Biological activity of the isothiazole derivatives]. Retrieved from [\[Link\]](#)
- PubMed. (n.d.). Synthesis, Cytotoxic Activity, and Molecular Docking Study of New Thiazole-Incorporated Indenopyridazine Derivatives as Potential Antiproliferative Drugs. Retrieved from [\[Link\]](#)
- ResearchGate. (n.d.). Cytotoxic screening of the tested thiazole derivatives 3a-5b. Data... Retrieved from [\[Link\]](#)
- MDPI. (2022, October 18). Mechanism of Action of Thiazolidin-2,4-dione. Retrieved from [\[Link\]](#)

### Need Custom Synthesis?

BenchChem offers custom synthesis for rare earth carbides and specific isotopic labeling.

Email: [info@benchchem.com](mailto:info@benchchem.com) or [Request Quote Online](#).

## Sources

1. [\[Biological activity of the isothiazole derivatives\]](#) - PubMed [[pubmed.ncbi.nlm.nih.gov](https://pubmed.ncbi.nlm.nih.gov)]
2. [Isothiazolopyridones: synthesis, structure, and biological activity of a new class of antibacterial agents](#) - PubMed [[pubmed.ncbi.nlm.nih.gov](https://pubmed.ncbi.nlm.nih.gov)]
3. [Synthesis of novel isothiazolopyridines and their in vitro evaluation against Mycobacterium and Propionibacterium acnes](#) - PubMed [[pubmed.ncbi.nlm.nih.gov](https://pubmed.ncbi.nlm.nih.gov)]

- [4. Synthesis and cytotoxic evaluation of some novel 3-\[2-\(2-phenyl-thiazol-4-yl\)-ethyl\]-3H-pyrido\[2,3-d\]pyrimidin-4-one derivatives - PMC \[pmc.ncbi.nlm.nih.gov\]](#)
- [5. researchgate.net \[researchgate.net\]](#)
- [6. books.rsc.org \[books.rsc.org\]](#)
- [7. pdf.benchchem.com \[pdf.benchchem.com\]](#)
- [8. Welcome to ToxTutor - Toxicology MSDT \[toxmsdt.com\]](#)
- [9. taylorandfrancis.com \[taylorandfrancis.com\]](#)
- [10. cmmcp.org \[cmmcp.org\]](#)
- [11. Cytotoxicity Assays: In Vitro Methods to Measure Dead Cells - Assay Guidance Manual - NCBI Bookshelf \[ncbi.nlm.nih.gov\]](#)
- [12. clyte.tech \[clyte.tech\]](#)
- [13. Cytotoxicity MTT Assay Protocols and Methods | Springer Nature Experiments \[experiments.springernature.com\]](#)
- [14. broadpharm.com \[broadpharm.com\]](#)
- [15. Cell Viability Assays - Assay Guidance Manual - NCBI Bookshelf \[ncbi.nlm.nih.gov\]](#)
- [16. What is the principle of LDH assay? | AAT Bioquest \[aatbio.com\]](#)
- [17. info.gbiosciences.com \[info.gbiosciences.com\]](#)
- [18. LDH-Glo™ Cytotoxicity Assay | LDHアッセイ | LDH放出 | J2380 | Promega \[promega.jp\]](#)
- [19. Apoptosis assays for quantifying the bioactivity of anticancer drug products - PubMed \[pubmed.ncbi.nlm.nih.gov\]](#)
- [20. Efficiently Evaluate the Effect of Drugs on Cell Apoptosis - Creative Diagnostics \[qbd.creative-diagnostics.com\]](#)
- [21. Apoptosis Assay Service - Creative Proteomics \[creative-proteomics.com\]](#)
- [22. bmglabtech.com \[bmglabtech.com\]](#)
- [23. researchgate.net \[researchgate.net\]](#)
- [24. reddit.com \[reddit.com\]](#)
- [25. mdpi.com \[mdpi.com\]](#)
- To cite this document: BenchChem. [Application Notes and Protocols for Evaluating Isothiazolopyridine Cytotoxicity]. BenchChem, [2026]. [Online PDF]. Available at: [<https://www.benchchem.com/product/b1345993/docs#application-notes-and-protocols-for-evaluating-isothiazolopyridine-cytotoxicity>]

**Disclaimer & Data Validity:**

The information provided in this document is for Research Use Only (RUO) and is strictly not intended for diagnostic or therapeutic procedures. While BenchChem strives to provide accurate protocols, we make no warranties, express or implied, regarding the fitness of this product for every specific experimental setup.

**Technical Support:** The protocols provided are for reference purposes. Unsure if this reagent suits your experiment?

**Need Industrial/Bulk Grade?** [Request Custom Synthesis Quote](#)

## BenchChem

Our mission is to be the trusted global source of essential and advanced chemicals, empowering scientists and researchers to drive progress in science and industry.

### Contact

Address: 3281 E Guasti Rd

Ontario, CA 91761, United States

Phone: (601) 213-4426

Email: [info@benchchem.com](mailto:info@benchchem.com)

[Contact our Ph.D. Support Team for a compatibility check](#)