

Derivatization protocols involving Methaqualone-d5

Author: BenchChem Technical Support Team. **Date:** April 2026

Compound of Interest

Compound Name: *Methaqualone-d5*

CAS No.: *1184966-71-9*

Cat. No.: *B13446661*

[Get Quote](#)

An Application Guide to Derivatization Protocols for **Methaqualone-d5** and its Metabolites in Mass Spectrometry

Abstract

This comprehensive application note provides a detailed guide for the derivatization of **Methaqualone-d5** and its hydroxylated metabolites, primarily for analysis by Gas Chromatography-Mass Spectrometry (GC-MS). As a deuterated internal standard, **Methaqualone-d5** is critical for achieving high accuracy and precision in the quantitative analysis of methaqualone in forensic toxicology and clinical research. While the parent compound can often be analyzed directly, its metabolites require derivatization to improve chromatographic performance and analytical sensitivity. This guide explains the underlying chemical principles, offers a detailed, field-tested silylation protocol, and provides troubleshooting insights for researchers, scientists, and drug development professionals.

Introduction: The Analytical Imperative for Methaqualone and its Isotopologues

Methaqualone (formerly marketed as Quaalude®) is a sedative-hypnotic drug that acts as a central nervous system depressant.[1][2] Despite being withdrawn from medical use due to its high potential for abuse and addiction, it remains a substance of concern in forensic analysis.[3][4] Accurate quantification of methaqualone in biological matrices is crucial for toxicological investigations.

The gold standard for such quantitative analysis is isotope dilution mass spectrometry, which employs a stable isotope-labeled internal standard (SIL-IS). **Methaqualone-d5**, a deuterated analog of the parent drug, serves this purpose. By adding a known quantity of **Methaqualone-d5** to a sample at the beginning of the extraction process, analysts can correct for sample loss during preparation and for matrix-induced variations in instrument response.[5][6] This ensures a high degree of confidence in the final quantitative results.

Methaqualone is extensively metabolized in the liver, primarily through hydroxylation at various positions on its aromatic rings.[7][8] These hydroxylated metabolites are more polar than the parent drug. For Gas Chromatography (GC) analysis, polar compounds often exhibit poor chromatographic behavior, including peak tailing and low volatility, which compromises sensitivity and resolution.[9][10] Chemical derivatization addresses this challenge by converting polar functional groups (like hydroxyl groups) into less polar, more volatile, and more thermally stable derivatives.[11] This guide focuses on the most common and effective derivatization strategy for this application: silylation.

The Rationale for Derivatization: A Focus on Silylation

Derivatization is a chemical modification process designed to enhance the analytical properties of a compound prior to analysis.[10] For GC-MS, the primary goals are:

- **Increased Volatility:** Replacing polar, active hydrogen atoms (e.g., in -OH groups) with a non-polar group reduces intermolecular hydrogen bonding, allowing the compound to vaporize at lower temperatures.
- **Improved Thermal Stability:** Derivatives are often more stable at the high temperatures of the GC injector and column, preventing on-column degradation.

- Enhanced Chromatographic Peak Shape: Reducing polarity minimizes interactions with active sites on the GC column, resulting in sharper, more symmetrical peaks.
- Characteristic Mass Spectra: Derivatization introduces specific chemical moieties that can produce unique and structurally informative fragment ions in the mass spectrometer, aiding in identification.

Why Silylation?

Silylation is the most prevalent derivatization technique for GC analysis, involving the replacement of an active hydrogen with a trimethylsilyl (TMS) or a similar silyl group.^{[12][13]} It is particularly effective for hydroxyl groups found in methaqualone metabolites. The reaction is typically fast, quantitative, and produces stable derivatives. Reagents like N,O-Bis(trimethylsilyl)trifluoroacetamide (BSTFA), often with a catalyst like Trimethylchlorosilane (TMCS), are highly effective for this purpose.^[14]

The workflow for sample analysis using a deuterated internal standard and derivatization is a multi-step process designed for maximum accuracy.

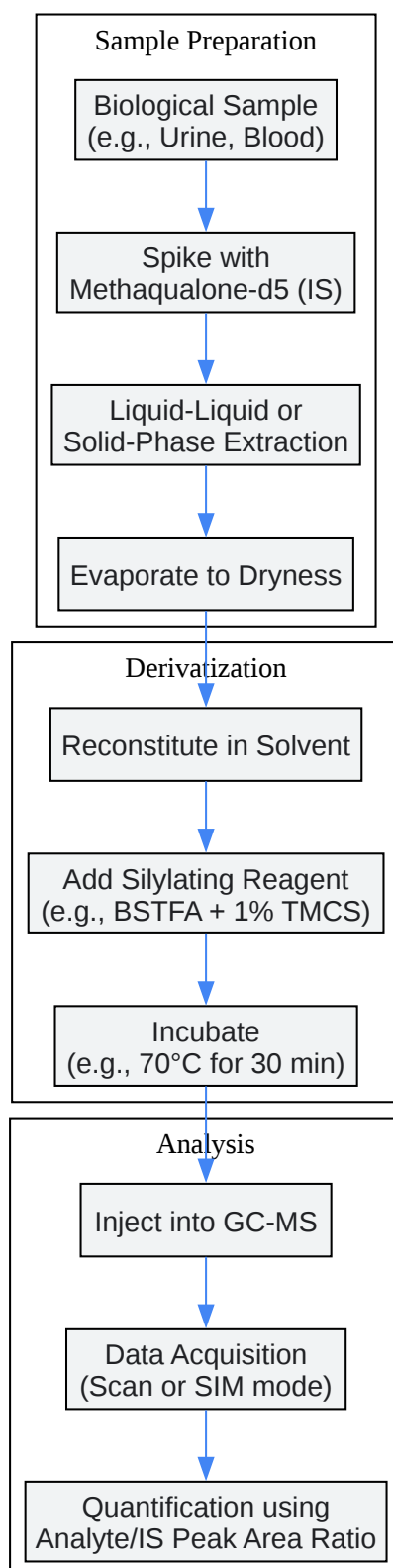

[Click to download full resolution via product page](#)

Caption: Analytical workflow for quantitative analysis.

Protocol: Silylation of Hydroxylated Methaqualone-d5 Analogs

This protocol details the derivatization of hydroxylated methaqualone metabolites using BSTFA with 1% TMCS as a catalyst. The same procedure applies to the deuterated (d5) and non-deuterated (d0) forms of the metabolites.

3.1. Principle of the Reaction

BSTFA reacts with the hydroxyl group (-OH) of the metabolite, replacing the acidic proton with a non-polar trimethylsilyl (TMS) group. The TMCS catalyst accelerates this reaction. The byproducts of the reaction are neutral and volatile, minimizing interference during GC-MS analysis.[12]

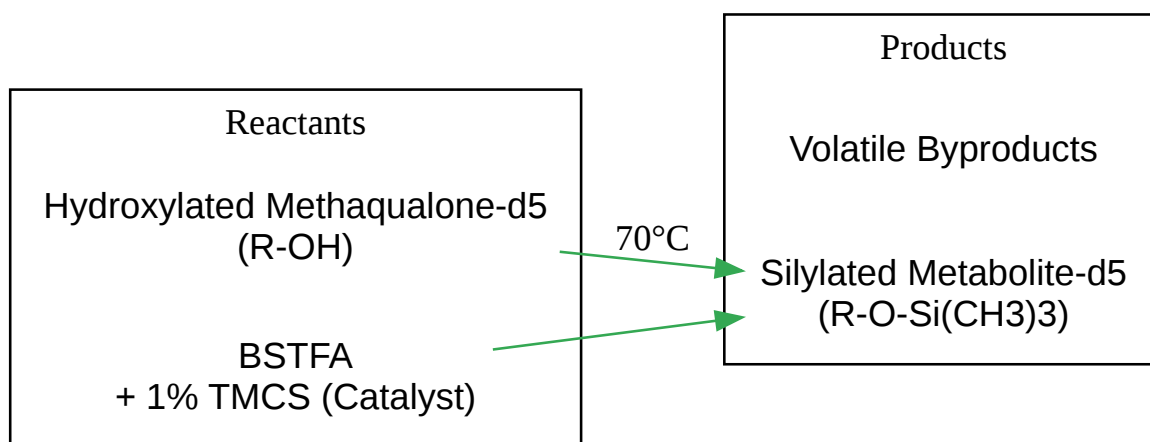

[Click to download full resolution via product page](#)

Caption: Silylation reaction scheme.

3.2. Materials and Reagents

| Item | Supplier Example | Purpose |
|---|-------------------|-----------------------|
| Methaqualone-d5 Standard | Cerilliant | Internal Standard |
| BSTFA + 1% TMCS | Sigma-Aldrich | Silylating Reagent |
| Acetonitrile or Pyridine (Anhydrous) | Fisher Scientific | Reaction Solvent |
| Conical Glass Vials (1 mL) with PTFE caps | VWR | Reaction Vessel |
| Heating Block or Water Bath | VWR | Incubation |
| Nitrogen Evaporator | Organomation | Solvent Removal |
| GC-MS System | Agilent, Shimadzu | Analytical Instrument |

3.3. Step-by-Step Protocol

- **Sample Preparation:** Following solid-phase or liquid-liquid extraction of the analyte and **Methaqualone-d5** internal standard from the biological matrix, evaporate the final solvent extract to complete dryness under a gentle stream of nitrogen at 40-50°C. It is critical to ensure the sample is free of water, as moisture will consume the silylating reagent.[\[15\]](#)
- **Reagent Addition:** To the dry residue in the vial, add 50 µL of anhydrous acetonitrile (or pyridine) to reconstitute.
- **Derivatization:** Add 50 µL of BSTFA + 1% TMCS to the vial.
- **Reaction:** Immediately cap the vial tightly. Vortex for 10-15 seconds to ensure thorough mixing.
- **Incubation:** Place the vial in a heating block or water bath set to 70°C for 30 minutes to facilitate the reaction.
- **Cooling:** Remove the vial from the heat source and allow it to cool to room temperature.
- **Analysis:** The sample is now ready for injection into the GC-MS system. An aliquot (typically 1-2 µL) can be directly injected.

3.4. Safety Precautions

- Derivatization reagents are moisture-sensitive and corrosive. Always handle them in a fume hood.
- Wear appropriate personal protective equipment (PPE), including safety glasses, gloves, and a lab coat.
- Ensure vials are tightly capped before heating to prevent pressure buildup and leakage.

GC-MS Instrumental Parameters

The following table provides typical starting parameters for the GC-MS analysis of silylated methaqualone metabolites. These should be optimized for the specific instrument and column in use.

| Parameter | Recommended Setting | Rationale |
|----------------------|---|--|
| GC System | | |
| Injection Port Temp. | 275°C | Ensures rapid and complete vaporization of the derivatized analytes. |
| Injection Mode | Splitless (1 µL injection) | Maximizes the transfer of analyte onto the column for trace-level analysis. |
| Carrier Gas | Helium, constant flow at 1.2 mL/min | Inert gas providing good chromatographic efficiency. |
| Column | 30 m x 0.25 mm ID, 0.25 µm film thickness (e.g., HP-5MS, DB-5MS) | A non-polar 5% phenyl-methylpolysiloxane column offers excellent separation for this class of compounds. |
| Oven Program | Initial: 150°C (hold 1 min), Ramp: 15°C/min to 280°C, Hold: 5 min | A temperature ramp effectively separates analytes based on their boiling points.[16] |
| MS System | | |
| Ion Source Temp. | 230°C | Standard temperature for electron ionization. |
| Quadrupole Temp. | 150°C | Standard temperature for the mass filter. |
| Ionization Mode | Electron Ionization (EI) at 70 eV | Provides reproducible fragmentation patterns for library matching and structural elucidation. |
| Acquisition Mode | Selected Ion Monitoring (SIM) | For quantitative analysis, SIM mode offers superior sensitivity and selectivity compared to full scan. |

SIM Ions (Example)

To be determined empirically

Select 2-3 characteristic, abundant ions for the analyte and the internal standard for quantification.

Expected Results and Troubleshooting

Upon successful derivatization, a significant decrease in retention time and a marked improvement in peak symmetry should be observed for hydroxylated metabolites compared to their underivatized forms. The mass spectrum of the TMS derivative will show a molecular ion (M^+) that is 72 Da higher for each silylated hydroxyl group. A characteristic fragment corresponding to the loss of a methyl group ($[M-15]^+$) is also typically prominent.

| Problem | Potential Cause(s) | Suggested Solution(s) |
|----------------------------------|---|--|
| Poor or No Derivatization | 1. Presence of moisture in the sample or solvent. 2. Inactive/degraded reagent. 3. Insufficient reaction time or temperature. | 1. Ensure complete dryness of the sample extract. Use anhydrous solvents. 2. Use a fresh vial of derivatizing reagent. Store reagents under inert gas and protect from moisture. 3. Increase incubation time or temperature (e.g., 80°C for 45 min). |
| Broad or Tailing Peaks | 1. Incomplete derivatization. 2. Active sites in the GC inlet liner or column. | 1. See solutions for "Poor or No Derivatization". 2. Use a deactivated inlet liner. Condition the GC column according to the manufacturer's instructions. An injection of a pure silylating reagent can help passivate the system. |
| Extraneous Peaks in Chromatogram | 1. Contamination from solvents or sample preparation. 2. Byproducts from the reagent. | 1. Analyze a solvent blank to identify sources of contamination. 2. These are usually well-resolved from the analyte peaks. If interference occurs, adjust the GC temperature program. |

Conclusion

The use of **Methaqualone-d5** as an internal standard is fundamental to the reliable quantification of methaqualone. For the analysis of its hydroxylated metabolites by GC-MS, a chemical derivatization step is not merely beneficial but essential for achieving the required volatility and chromatographic performance. The silylation protocol described in this application note, utilizing BSTFA with a TMCS catalyst, provides a robust and reproducible method for converting polar metabolites into derivatives suitable for sensitive and accurate analysis. By

understanding the principles behind this technique and adhering to the detailed protocol, researchers can generate high-quality, defensible data in both clinical and forensic settings.

References

- Title: Comparison of methaqualone excretion patterns using Abuscreen ONLINE and EMIT II immunoassays and GC/MS.[7] Source: PubMed URL:[[Link](#)]
- Title: Variations in human metabolism of methaqualone given in therapeutic doses and in overdose cases studied by gas chromatography-mass spectrometry.[17] Source: PlumX URL:[[Link](#)]
- Title: Identification of Free and Conjugated Metabolites of Methaqualone by Gas Chromatography—Mass Spectrometry.[18] Source: Oxford Academic (Clinical Chemistry) URL:[[Link](#)]
- Title: Recommended methods for the identification and analysis of methaqualone/mecloqualone.[16] Source: United Nations Office on Drugs and Crime (UNODC) URL:[[Link](#)]
- Title: Analysis of methaqualone in biological matrices by micellar electrokinetic capillary chromatography. Comparison with gas chromatography-mass spectrometry.[19] Source: PubMed URL:[[Link](#)]
- Title: Analysis of Illicit Methaqualone Containing Preparations by Gas Chromatography-Mass Spectrometry for Forensic Purposes.[20] Source: Office of Justice Programs URL:[[Link](#)]
- Title: From historical drugs to present perils: UHPLC-QqQ-MS/MS determination of methaqualone and its designer analogs (NPS) with comprehensive fragmentation pathways study (QTOF).[21] Source: PubMed URL:[[Link](#)]
- Title: Derivatization reagents for GC.[12] Source: Macherey-Nagel URL:[[Link](#)]
- Title: Recommended methods for the identification and analysis of methaqualone / mecloqualone. For use by national drug analysis laboratories.[22] Source: Drugs and Alcohol URL:[[Link](#)]

- Title: Recommended Methods for Testing Methaqualone/Mecloqualone.[23] Source: UNODC URL:[[Link](#)]
- Title: Guide to Derivatization Reagents for GC. Source: LabRulez GCMS URL:[[Link](#)]
- Title: Methaqualone (CAS 72-44-6) - Chemical & Physical Properties.[24] Source: Cheméo URL:[[Link](#)]
- Title: Synthesis of Deuterated Endochin-Like Quinolones.[5] Source: PMC (PubMed Central) URL:[[Link](#)]
- Title: Deuterated Internal Standards for LC-MS: Selection & Custom Synthesis.[6] Source: ResolveMass Laboratories URL:[[Link](#)]
- Title: Quaaludes.[1] Source: Drug Science URL:[[Link](#)]
- Title: The Synthesis of Deuterated Isohumulones for Use as Internal Standards in LC-MS Stable Isotope Dilution Assays. Source: UMSL URL:[[Link](#)]
- Title: Methaqualone.[2] Source: PubChem URL:[[Link](#)]
- Title: Methaqualone.[3] Source: Wikipedia URL:[[Link](#)]
- Title: Chemical derivatization for the analysis of drugs by GC-MS - A conceptual review.[9] Source: Journal of Food and Drug Analysis URL:[[Link](#)]
- Title: Chemical derivatization for the analysis of drugs by GC-MS - A conceptual review.[10] Source: Semantic Scholar URL:[[Link](#)]
- Title: Derivatization Reactions and Reagents for Gas Chromatography Analysis.[11] Source: SciSpace URL:[[Link](#)]
- Title: SCITEC/13 December 1996.[8] Source: UNODC URL:[[Link](#)]
- Title: Deuterated Internal Standards for LC-MS: Selection & Custom Synthesis. Source: YouTube URL:[[Link](#)]

- Title: A survey of reported synthesis of methaqualone and some positional and structural isomers.[4] Source: Rhodium.ws URL:[[Link](#)]
- Title: Derivatization for GC-MS analysis?[15] Source: ResearchGate URL:[[Link](#)]

Need Custom Synthesis?

BenchChem offers custom synthesis for rare earth carbides and specific isotopic labeling.

Email: info@benchchem.com or [Request Quote Online](#).

Sources

1. drugscience.org.uk [drugscience.org.uk]
2. Methaqualone | C₁₆H₁₄N₂O | CID 6292 - PubChem [pubchem.ncbi.nlm.nih.gov]
3. Methaqualone - Wikipedia [en.wikipedia.org]
4. A survey of reported synthesis of methaqualone and some positional and structural isomers - [www.rhodium.ws] [chemistry.mdma.ch]
5. Synthesis of Deuterated Endochin-Like Quinolones - PMC [pmc.ncbi.nlm.nih.gov]
6. resolvemass.ca [resolvemass.ca]
7. Comparison of methaqualone excretion patterns using Abuscreen ONLINE and EMIT II immunoassays and GC/MS - PubMed [pubmed.ncbi.nlm.nih.gov]
8. unodc.org [unodc.org]
9. jfda-online.com [jfda-online.com]
10. semantic scholar.org [semantic scholar.org]
11. scispace.com [scispace.com]
12. mn-net.com [mn-net.com]
13. GC Derivatization Reagents | [Analytical Chemistry]Products | Laboratory Chemicals-FUJIFILM Wako Pure Chemical Corporation [labchem-wako.fujifilm.com]
14. GC 試薬 | Thermo Fisher Scientific - JP [thermofisher.com]
15. researchgate.net [researchgate.net]
16. syntheticdrugs.unodc.org [syntheticdrugs.unodc.org]

- [17. PlumX \[plu.mx\]](#)
- [18. academic.oup.com \[academic.oup.com\]](#)
- [19. Analysis of methaqualone in biological matrices by micellar electrokinetic capillary chromatography. Comparison with gas chromatography-mass spectrometry - PubMed \[pubmed.ncbi.nlm.nih.gov\]](#)
- [20. Analysis of Illicit Methaqualone Containing Preparations by Gas Chromatography-Mass Spectrometry for Forensic Purposes | Office of Justice Programs \[ojp.gov\]](#)
- [21. From historical drugs to present perils: UHPLC-QqQ-MS/MS determination of methaqualone and its designer analogs \(NPS\) with comprehensive fragmentation pathways study \(QTOF\) - PubMed \[pubmed.ncbi.nlm.nih.gov\]](#)
- [22. Recommended methods for the identification and analysis of methaqualone / mecloqualone. For use by national drug analysis laboratories. - Drugs and Alcohol \[drugsandalcohol.ie\]](#)
- [23. Recommended Methods for Testing Methaqualone/Mecloqualone \[unodc.org\]](#)
- [24. Methaqualone \(CAS 72-44-6\) - Chemical & Physical Properties by Cheméo \[cheméo.com\]](#)
- [To cite this document: BenchChem. \[Derivatization protocols involving Methaqualone-d5\]. BenchChem, \[2026\]. \[Online PDF\]. Available at: \[https://www.benchchem.com/product/b13446661/docs#derivatization-protocols-involving-methaqualone-d5\]](#)

Disclaimer & Data Validity:

The information provided in this document is for Research Use Only (RUO) and is strictly not intended for diagnostic or therapeutic procedures. While BenchChem strives to provide accurate protocols, we make no warranties, express or implied, regarding the fitness of this product for every specific experimental setup.

Technical Support: The protocols provided are for reference purposes. Unsure if this reagent suits your experiment?

Need Industrial/Bulk Grade? [Request Custom Synthesis Quote](#)

BenchChem

Our mission is to be the trusted global source of essential and advanced chemicals, empowering scientists and researchers to drive progress in science and industry.

Contact

Address: 3281 E Guasti Rd

Ontario, CA 91761, United States

Phone: (601) 213-4426

Email: info@benchchem.com

[Contact our Ph.D. Support Team for a compatibility check](#)