

Application Notes and Protocols for Target Identification of Trigonothylin C

Author: BenchChem Technical Support Team. **Date:** April 2026

Compound of Interest

Compound Name: *Trigonothylin C*

Cat. No.: *B13442970*

[Get Quote](#)

For Researchers, Scientists, and Drug Development Professionals

Introduction

Natural products are a rich source of novel chemical entities with therapeutic potential. However, a significant bottleneck in their development is the identification of their molecular targets, a critical step for understanding their mechanism of action, optimizing their activity, and assessing potential toxicities.^{[1][2]} This document provides a detailed guide for the target identification of a novel natural product, exemplified by "**Trigonothylin C**," for which no prior target information is assumed.

The challenge with many natural products is their limited availability and the potential loss of activity upon chemical modification, making traditional affinity-based methods that require probe synthesis difficult.^{[3][4]} Therefore, this guide focuses on a multi-pronged, label-free approach, combining complementary techniques to increase the probability of identifying high-confidence protein targets. The proposed workflow integrates Drug Affinity Responsive Target Stability (DARTS) and Cellular Thermal Shift Assay (CETSA), followed by a more traditional affinity-based proteomic approach for validation and deeper characterization.^{[5][6][7][8][9]}

Overall Target Identification Workflow

The recommended strategy for identifying the cellular targets of **Trigonothylin C** is a phased approach, starting with broad, unbiased screening and moving towards specific validation.

Caption: Overall workflow for **Trigonothylin C** target identification.

Method 1: Drug Affinity Responsive Target Stability (DARTS)

The DARTS method is based on the principle that when a small molecule binds to a protein, it stabilizes the protein's structure, making it more resistant to protease digestion.^{[6][7]} This allows for the identification of target proteins in complex mixtures like cell lysates without modifying the small molecule.^{[5][6]}

Experimental Workflow for DARTS

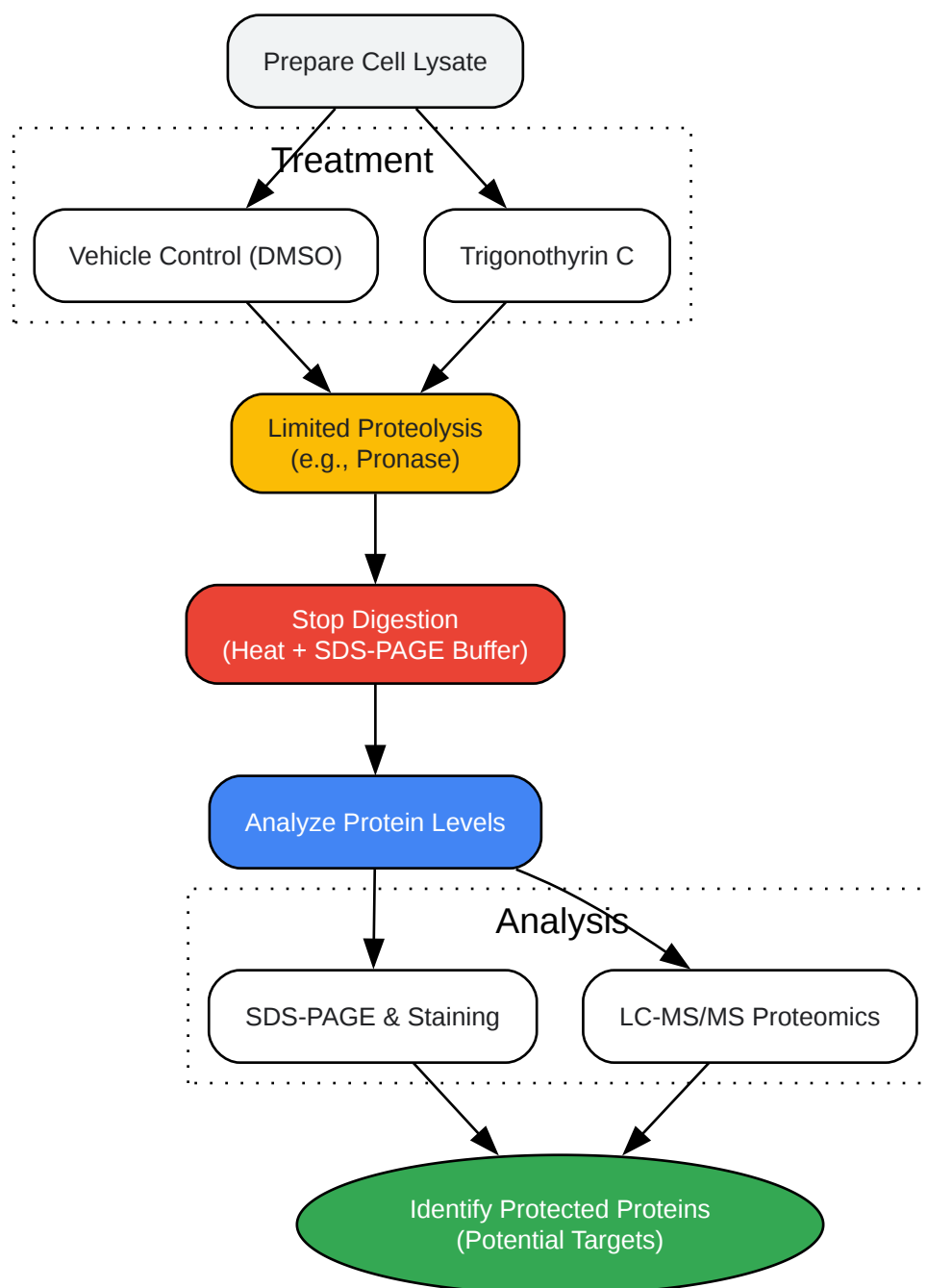

[Click to download full resolution via product page](#)

Caption: Experimental workflow for the DARTS protocol.

Protocol for DARTS

- Cell Lysate Preparation:
 - Culture cells of interest (e.g., a human cancer cell line) to ~80-90% confluency.

- Harvest cells and wash twice with ice-cold PBS.
- Lyse cells in M-PER buffer (or a similar mild lysis buffer without detergents that would denature proteins) supplemented with protease inhibitors.
- Centrifuge at 14,000 x g for 15 minutes at 4°C to pellet cell debris.
- Collect the supernatant (total protein lysate) and determine the protein concentration using a BCA assay.
- Compound Treatment:
 - In separate tubes, dilute the protein lysate to a final concentration of 1 mg/mL.
 - For the treatment group, add **Trigonothylin C** to a final concentration (e.g., 10 μM).
 - For the control group, add the same volume of vehicle (e.g., DMSO).
 - Incubate at room temperature for 1 hour to allow for binding.
- Protease Digestion:
 - Prepare a stock solution of a broad-spectrum protease like Pronase.
 - Add the protease to both the treated and control samples. The optimal protease concentration needs to be determined empirically, but a starting point is a 1:100 to 1:300 protease-to-protein ratio (w/w).[6]
 - Incubate at room temperature for a defined period (e.g., 10-30 minutes).
- Stopping the Reaction:
 - Stop the digestion by adding 5X SDS-PAGE loading buffer and boiling the samples at 95°C for 5 minutes.
- Analysis:
 - SDS-PAGE: Run the digested samples on an SDS-PAGE gel. Stain with Coomassie Blue or a silver stain. Look for bands that are present or more intense in the **Trigonothylin C-**

treated lane compared to the control lane. These bands can be excised and identified by mass spectrometry.

- LC-MS/MS (for unbiased identification): The entire sample is subjected to tryptic digestion (after the initial limited proteolysis is stopped) and analyzed by quantitative mass spectrometry (e.g., using SILAC or label-free quantification). Proteins that are significantly more abundant in the **Trigonothylin C**-treated sample are considered potential targets.

Data Presentation: DARTS Mass Spectrometry Hits

Rank	Protein ID (UniProt)	Gene Name	Fold Change (Trigonothylin C / DMSO)	p-value	Function
1	P04637	TP53	5.8	0.001	Tumor Suppressor
2	P00533	EGFR	4.2	0.005	Tyrosine Kinase
3	P62258	HSP90AB1	3.5	0.012	Chaperone
...

Method 2: Cellular Thermal Shift Assay (CETSA)

CETSA is a powerful method to confirm direct target engagement in a cellular environment.^[9] It relies on the principle that ligand binding alters the thermal stability of a protein.^{[8][10]} This change in stability can be detected by heating cell lysates or intact cells to various temperatures and then quantifying the amount of soluble protein remaining.^{[10][11]}

Principle of CETSA

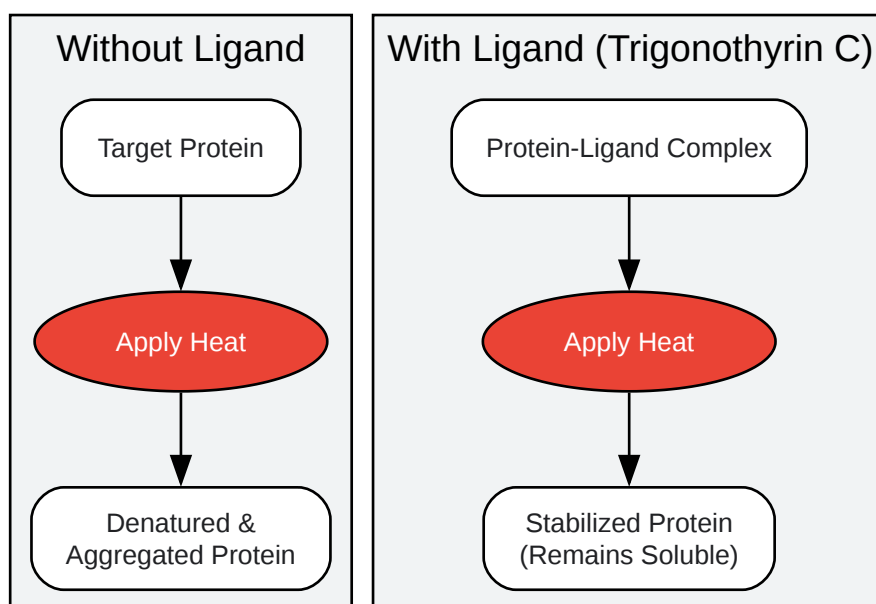

Result: Increased soluble protein in the presence of the ligand at elevated temperatures.

[Click to download full resolution via product page](#)

Caption: Principle of the Cellular Thermal Shift Assay (CETSA).

Protocol for CETSA (Western Blot Readout)

- Cell Treatment:
 - Culture cells in multiple dishes. Treat one set with **Trigonothylin C** at a desired concentration and the other with vehicle (DMSO) for 1-2 hours.
- Heating Step:
 - Harvest the treated cells and resuspend them in PBS containing protease inhibitors.
 - Aliquot the cell suspension into separate PCR tubes for each temperature point.
 - Heat the tubes at a range of different temperatures (e.g., 40°C, 45°C, 50°C, 55°C, 60°C, 65°C) for 3 minutes in a thermal cycler. One aliquot should be kept at room temperature as a control.

- Lysis and Fractionation:
 - Lyse the cells by freeze-thawing (e.g., three cycles of liquid nitrogen and a 25°C water bath).
 - Centrifuge at 20,000 x g for 20 minutes at 4°C to separate the soluble fraction (supernatant) from the aggregated proteins (pellet).
- Analysis by Western Blot:
 - Collect the supernatant from each sample.
 - Analyze the protein levels of the suspected target (identified from DARTS) by Western blot.
 - A positive result is a "shift" in the melting curve, where the protein remains soluble at higher temperatures in the drug-treated samples compared to the control.

Data Presentation: CETSA Dose-Response

Trigonothylin C (µM)	Apparent Tagg (°C)	ΔTagg (°C) vs. DMSO
0 (DMSO)	52.5	0.0
0.1	53.1	0.6
1	55.8	3.3
10	58.2	5.7
100	58.5	6.0

Method 3: Affinity-Based Proteomics

While label-free methods are advantageous, traditional affinity-based approaches, where the small molecule is immobilized on a solid support, remain a powerful tool for target identification. [\[12\]](#)[\[13\]](#) This method directly captures binding partners from a cell lysate.[\[1\]](#)

Protocol for Affinity-Based Proteomics

- Probe Synthesis:
 - Synthesize a derivative of **Trigonothylin C** that contains a linker and a reactive group (e.g., an alkyne or azide for click chemistry, or a biotin tag). It is crucial to test this derivative to ensure it retains its biological activity.
- Immobilization:
 - Covalently attach the **Trigonothylin C** probe to a solid support, such as sepharose beads.
 - Prepare control beads that are derivatized only with the linker and tag, without the compound.
- Affinity Pulldown:
 - Incubate the **Trigonothylin C**-beads and control beads with cell lysate for 2-4 hours at 4°C.
 - To reduce non-specific binding, a competition experiment can be performed where the lysate is pre-incubated with an excess of free, unmodified **Trigonothylin C** before adding the beads.
- Washing and Elution:
 - Wash the beads extensively with lysis buffer to remove non-specifically bound proteins.
 - Elute the bound proteins, typically by boiling in SDS-PAGE loading buffer.
- Analysis:
 - Separate the eluted proteins on an SDS-PAGE gel.
 - Identify specific binders by comparing the lanes from the **Trigonothylin C**-beads, control beads, and the competition experiment.
 - Excise unique bands for identification by mass spectrometry, or analyze the entire eluate using quantitative proteomics.

Data Presentation: Affinity-Based Proteomics Hits

Protein ID (UniProt)	Gene Name	Spectral Counts (Trigonothyrim C Beads)	Spectral Counts (Control Beads)	Specificity Ratio
P00533	EGFR	152	5	30.4
Q13547	PIK3CB	88	2	44.0
P42336	MAPK1	75	8	9.4
...

Hypothetical Signaling Pathway Modulation

Once a high-confidence target is identified (e.g., a kinase like EGFR), its role in cellular signaling can be investigated. Bioinformatics analysis of the hit list can reveal enriched pathways, providing context for the biological activity of **Trigonothyrim C**.

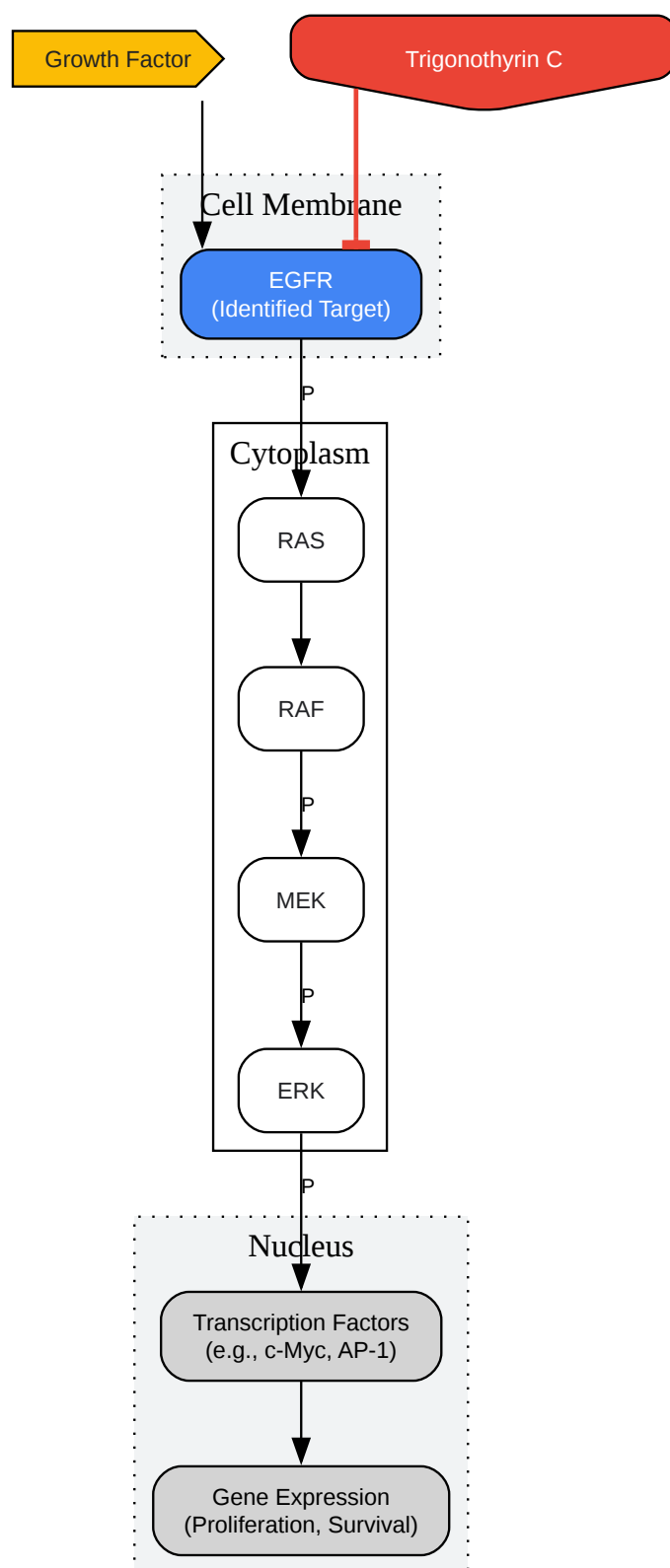

[Click to download full resolution via product page](#)

Caption: Hypothetical inhibition of the EGFR signaling pathway by **Trigonothylin C**.

Need Custom Synthesis?

BenchChem offers custom synthesis for rare earth carbides and specific isotopic labeling.

Email: info@benchchem.com or [Request Quote Online](#).

References

- 1. [Frontiers | Currently Available Strategies for Target Identification of Bioactive Natural Products \[frontiersin.org\]](#)
- 2. [researchgate.net \[researchgate.net\]](#)
- 3. [An update of label-free protein target identification methods for natural active products - PMC \[pmc.ncbi.nlm.nih.gov\]](#)
- 4. [Strategies for target identification of antimicrobial natural products - Natural Product Reports \(RSC Publishing\) \[pubs.rsc.org\]](#)
- 5. [Step-by-Step Protocol: How to Perform a DARTS Assay - Creative Proteomics \[creative-proteomics.com\]](#)
- 6. [Target identification using drug affinity responsive target stability \(DARTS\) - PMC \[pmc.ncbi.nlm.nih.gov\]](#)
- 7. [Drug affinity responsive target stability \(DARTS\) for small-molecule target identification - PubMed \[pubmed.ncbi.nlm.nih.gov\]](#)
- 8. [Cellular Thermal Shift Assay for the Detection of Small Molecule–Target Interactions in Arabidopsis Cells | Springer Nature Experiments \[experiments.springernature.com\]](#)
- 9. [High-Throughput Cellular Thermal Shift Assay \(CETSA\) using Acoustic Transfer of Protein Lysates - PMC \[pmc.ncbi.nlm.nih.gov\]](#)
- 10. [tandfonline.com \[tandfonline.com\]](#)
- 11. [pubs.acs.org \[pubs.acs.org\]](#)
- 12. [Emerging Affinity-Based Techniques in Proteomics - PMC \[pmc.ncbi.nlm.nih.gov\]](#)
- 13. [Affinity proteomics to study endogenous protein complexes: Pointers, pitfalls, preferences and perspectives - PMC \[pmc.ncbi.nlm.nih.gov\]](#)
- To cite this document: BenchChem. [Application Notes and Protocols for Target Identification of Trigonothylin C]. BenchChem, [2026]. [Online PDF]. Available at: [\[https://www.benchchem.com/product/b13442970/docs#application-notes-and-protocols-for-target-identification-of-trigonothylin-c\]](https://www.benchchem.com/product/b13442970/docs#application-notes-and-protocols-for-target-identification-of-trigonothylin-c)

Disclaimer & Data Validity:

The information provided in this document is for Research Use Only (RUO) and is strictly not intended for diagnostic or therapeutic procedures. While BenchChem strives to provide accurate protocols, we make no warranties, express or implied, regarding the fitness of this product for every specific experimental setup.

Technical Support: The protocols provided are for reference purposes. Unsure if this reagent suits your experiment?

Need Industrial/Bulk Grade? [Request Custom Synthesis Quote](#)

BenchChem

Our mission is to be the trusted global source of essential and advanced chemicals, empowering scientists and researchers to drive progress in science and industry.

Contact

Address: 3281 E Guasti Rd

Ontario, CA 91761, United States

Phone: (601) 213-4426

Email: info@benchchem.com

[Contact our Ph.D. Support Team for a compatibility check](#)