

An In-depth Technical Guide to Key Molecules in Cellular Signaling

Author: BenchChem Technical Support Team. **Date:** April 2026

Compound of Interest

Compound Name: A2B57
Cat. No.: B13440105

[Get Quote](#)

Introduction

The designation "**A2B57**" does not correspond to a recognized molecule in the scientific literature. It is likely a typographical error. This guide provides an in-depth analysis of two plausible candidates that researchers in cellular signaling might be investigating: the A2B Adenosine Receptor (ADORA2B) and ERp57 (also known as PDIA3 or GRP58). Both play critical roles in a variety of cellular signaling pathways and are relevant to researchers, scientists, and drug development professionals.

Section 1: The A2B Adenosine Receptor (ADORA2B)

The A2B adenosine receptor is a G-protein coupled receptor (GPCR) that belongs to the family of adenosine receptors.[1] It is characterized by its relatively low affinity for its endogenous ligand, adenosine, suggesting its activation primarily occurs in conditions of high adenosine concentration, such as inflammation or hypoxia.[2] ADORA2B is widely expressed and plays a significant role in inflammation, angiogenesis, and various physiological and pathological processes.[2][3]

Core Signaling Pathways of ADORA2B

ADORA2B is known for its promiscuous coupling to different G proteins, leading to the activation of multiple downstream signaling cascades. The primary pathways are mediated by Gs and Gq proteins.[3][4][5]

- **Gs-cAMP-PKA Pathway:** The canonical signaling pathway for ADORA2B involves its coupling to the Gs alpha subunit, which activates adenylyl cyclase. This leads to an increase in intracellular cyclic AMP (cAMP) levels and subsequent activation of Protein Kinase A (PKA).[3][6][7] This pathway is often associated with anti-inflammatory responses.[4]
- **Gq-PLC-Ca²⁺ Pathway:** ADORA2B can also couple to Gq proteins, activating Phospholipase C (PLC).[3][4] PLC hydrolyzes phosphatidylinositol 4,5-bisphosphate (PIP₂) into inositol trisphosphate (IP₃) and diacylglycerol (DAG). IP₃ triggers the release of calcium (Ca²⁺) from intracellular stores, and DAG activates Protein Kinase C (PKC).[3] This pathway has been implicated in pro-inflammatory responses, such as mast cell degranulation.[4]
- **MAP Kinase Pathway:** The A_{2B} receptor is unique among adenosine receptors in its ability to activate MAP kinase signaling pathways, including ERK1/2, JNK, and p38.[4] The exact mechanism of activation, whether through Gs or Gq coupling, is still under investigation and may be cell-type dependent.[4]

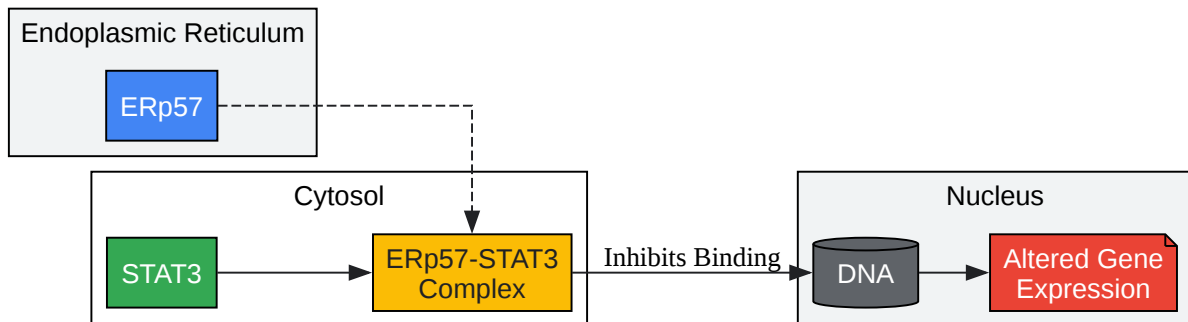
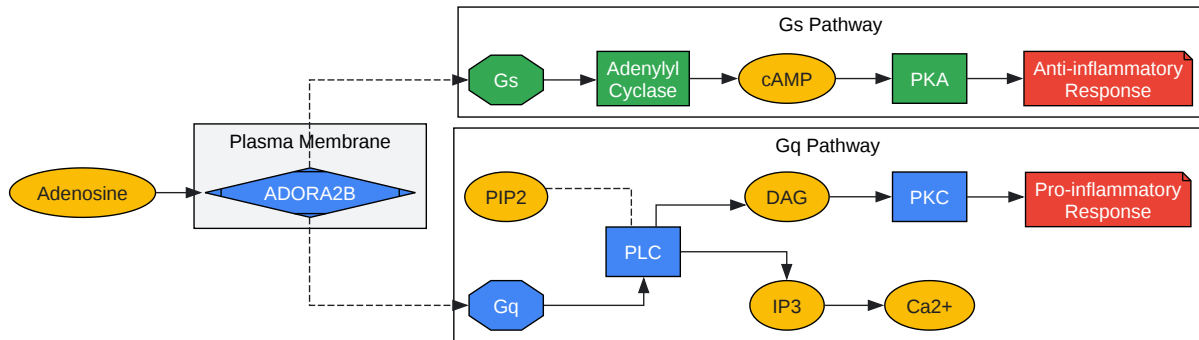

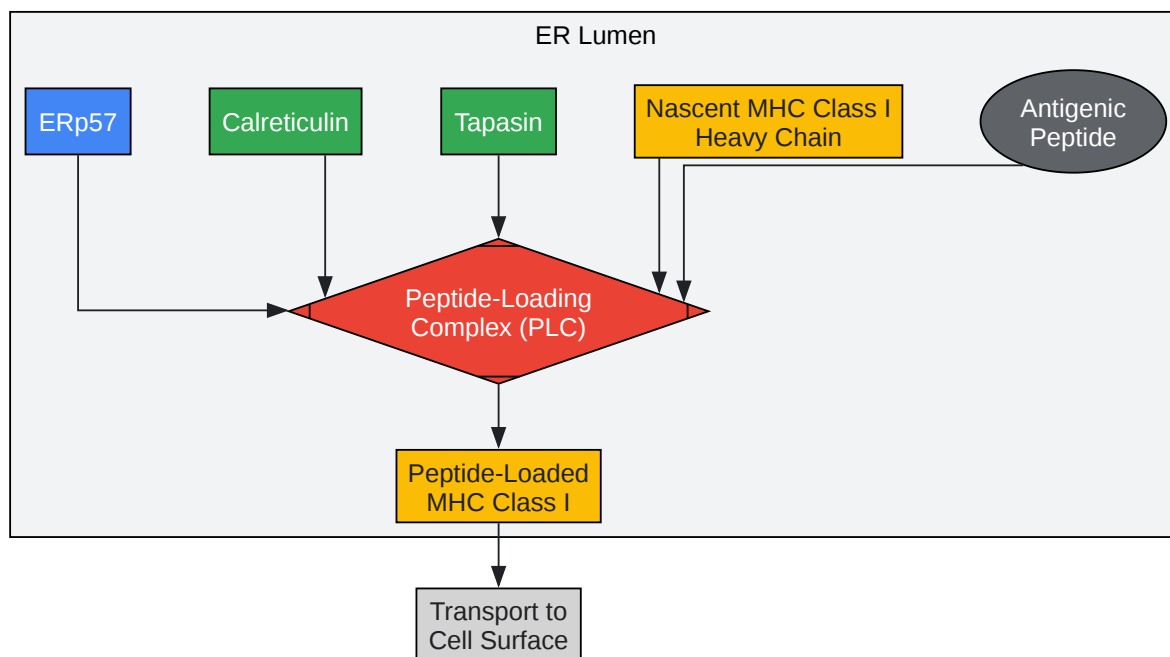

[Click to download full resolution via product page](#)

Need Custom Synthesis?

BenchChem offers custom synthesis for rare earth carbides and specific isotopic labeling.

Email: info@benchchem.com or [Request Quote Online](#).

References

- 1. Adenosine A2B receptor - Wikipedia [en.wikipedia.org]
- 2. A2B adenosine receptor signaling and regulation - PMC [pubmed.ncbi.nlm.nih.gov]
- 3. A2B adenosine receptors in immunity and inflammation - PMC [pubmed.ncbi.nlm.nih.gov]
- 4. The resurgence of A2B adenosine receptor signaling - PMC [pubmed.ncbi.nlm.nih.gov]

- [5. A2b adenosine receptors can change their spots - PMC \[pmc.ncbi.nlm.nih.gov\]](#)
- [6. Signaling pathways involving adenosine A2A and A2B receptors in wound healing and fibrosis - PMC \[pmc.ncbi.nlm.nih.gov\]](#)
- [7. Frontiers | Adenosine A2B Receptor: From Cell Biology to Human Diseases \[frontiersin.org\]](#)
- To cite this document: BenchChem. [An In-depth Technical Guide to Key Molecules in Cellular Signaling]. BenchChem, [2026]. [Online PDF]. Available at: [\[https://www.benchchem.com/product/b13440105/docs#an-in-depth-technical-guide-to-key-molecules-in-cellular-signaling\]](https://www.benchchem.com/product/b13440105/docs#an-in-depth-technical-guide-to-key-molecules-in-cellular-signaling)

Disclaimer & Data Validity:

The information provided in this document is for Research Use Only (RUO) and is strictly not intended for diagnostic or therapeutic procedures. While BenchChem strives to provide accurate protocols, we make no warranties, express or implied, regarding the fitness of this product for every specific experimental setup.

Technical Support: The protocols provided are for reference purposes. Unsure if this reagent suits your experiment?

Need Industrial/Bulk Grade? [Request Custom Synthesis Quote](#)

BenchChem

Our mission is to be the trusted global source of essential and advanced chemicals, empowering scientists and researchers to drive progress in science and industry.

Contact

Address: 3281 E Guasti Rd
Ontario, CA 91761, United States
Phone: (601) 213-4426
Email: info@benchchem.com

Contact our Ph.D. Support Team for a compatibility check