

# Technical Guide: Mitigating Cysteine Protease Cross-Reactivity in Pro-Arg-AMC Assays

**Author:** BenchChem Technical Support Team. **Date:** May 2026

## Compound of Interest

Compound Name: *Pro-Arg-AMC*

Cat. No.: *B1344021*

[Get Quote](#)

## Executive Summary: The Dual Identity of Pro-Arg-AMC

The fluorogenic substrate **Pro-Arg-AMC** (often supplied as Z-Gly-**Pro-Arg-AMC** or Boc-Val-**Pro-Arg-AMC**) is widely recognized as a standard tool for monitoring serine proteases, particularly Thrombin and Tissue Kallikrein. Its specificity relies on the P1 Arginine (basic) and P2 Proline (restrictive) residues, which perfectly match the S1/S2 pockets of these coagulation and kinin-system enzymes.

However, a critical oversight in complex biological assays (e.g., tissue lysates, cell culture supernatants) is the cross-reactivity of this motif with Cysteine Proteases, specifically Cathepsin K and, to a lesser extent, Cathepsin L. Unlike typical Papain-like cysteine proteases that prefer hydrophobic P2 residues (like Phenylalanine), Cathepsin K possesses a unique S2 pocket plasticity that accommodates Proline.

The Consequence: Researchers assaying Thrombin activity in bone, lung, or tumor lysates without specific inhibitors may observe significant false-positive signals driven by Cathepsin K, leading to erroneous conclusions about coagulation pathway activation.

This guide provides the mechanistic basis for this cross-reactivity, comparative performance data, and a self-validating "Inhibitor Suppression Check" (ISC) protocol to ensure data integrity.

## Mechanistic Basis of Cross-Reactivity

To understand why a "serine protease substrate" is cleaved by cysteine proteases, we must look at the structural determinants of the S2 subsite.

### The Serine Protease "Lock" (Thrombin)

Thrombin is a trypsin-like serine protease with a rigid active site.

- S1 Pocket: Deep and negatively charged (Asp189), strictly requiring Arginine or Lysine (P1).
- S2 Pocket: The "aryl-binding" site is shaped by the 60-loop. Proline at P2 provides a rigid, optimal fit that positions the scissile bond for attack by the catalytic Serine-195.

### The Cysteine Protease "Key" (Cathepsin K)

Most Papain-like cysteine proteases (e.g., Cathepsin B, L) have a hydrophobic S2 pocket that strongly prefers Phenylalanine or Leucine (hence Z-Phe-Arg-AMC is the gold standard for them).

- The Exception (Cathepsin K): Cathepsin K is unique among its family. Its S2 pocket is more open and can accept Proline. This allows it to degrade collagen (rich in Proline) efficiently.
- The Result: Cathepsin K recognizes the Pro-Arg motif in Z-Gly-**Pro-Arg-AMC** with high catalytic efficiency, effectively mimicking Thrombin's substrate recognition.

## Structural Comparison

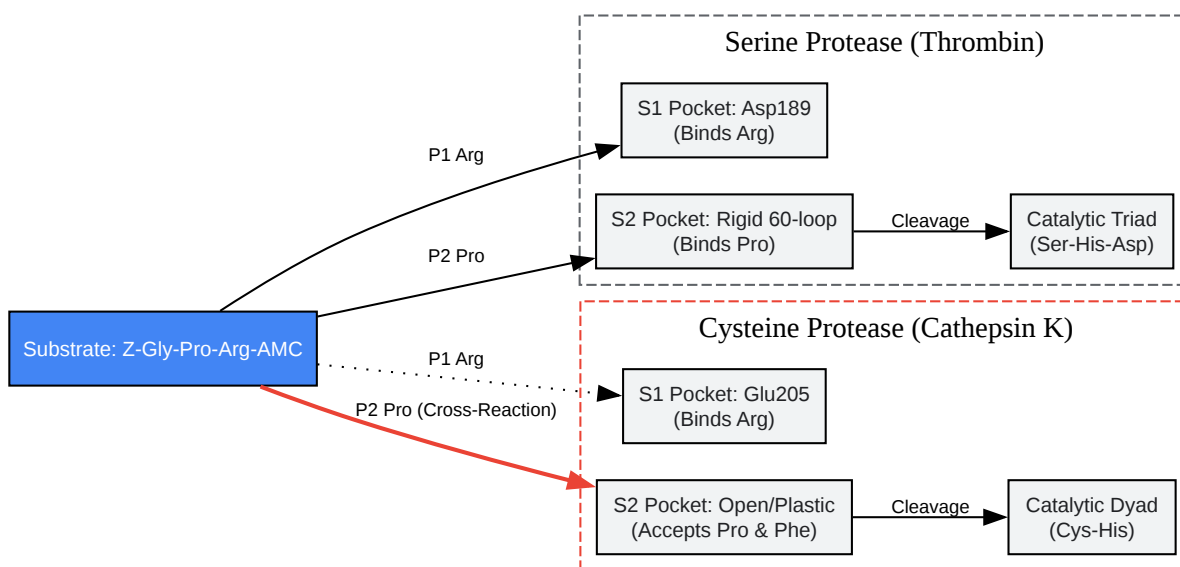

[Click to download full resolution via product page](#)

Figure 1: Structural logic of cross-reactivity. While Thrombin (Serine) relies on Proline for optimal fit, Cathepsin K (Cysteine) tolerates it due to S2 pocket plasticity, leading to unintended cleavage.

## Comparative Profiling: Target vs. Non-Target

The following table summarizes the activity of **Pro-Arg-AMC** against its intended targets and the primary confounding cysteine proteases.

Enzyme Class	Enzyme	Interaction with Pro-Arg-AMC	Specificity Risk	Inhibitor Profile (for differentiation)
Serine (Target)	Thrombin	High Efficiency ( )	N/A (Intended)	Inhibited by AEBSF, PMSF, Hirudin. Resistant to E-64.
Serine (Target)	Tissue Kallikrein	High Efficiency	N/A (Intended)	Inhibited by AEBSF, PMSF. Resistant to E-64.
Cysteine (Non-Target)	Cathepsin K	High Efficiency	Critical	Inhibited by E-64, Odanacatib. Resistant to AEBSF.
Cysteine (Non-Target)	Cathepsin L	Low to Moderate	Moderate	Inhibited by E-64. Prefers Phe-Arg-AMC.
Cysteine (Non-Target)	Cathepsin B	Very Low	Low	Inhibited by E-64, CA-074. Strictly prefers Arg-Arg or Phe-Arg.

Key Insight: If your sample contains bone tissue, macrophages, or osteoclasts, Cathepsin K is the primary source of false positives. In general tissue homogenates, Cathepsin L may contribute background signal.

## Experimental Protocol: The "Inhibitor Suppression Check" (ISC)

To validate data derived from **Pro-Arg-AMC** in complex matrices, you must perform a differential inhibition assay. This protocol mathematically isolates the fraction of fluorescence generated by the target class.

## Reagents Required

- Substrate: Z-Gly-**Pro-Arg-AMC** (10 mM stock in DMSO).
- Buffer: 50 mM Tris-HCl, pH 7.4 (Note: Cysteine proteases are active at pH 7.4, though their optimum is acidic. Do not assume neutral pH eliminates them).
- Inhibitor A (Cysteine-Specific): E-64 (100  $\mu$ M final). Irreversibly inhibits Cathepsins B, H, L, and K. Does not inhibit Serine proteases.
- Inhibitor B (Serine-Specific): AEBSF (1 mM final) or PMSF. Irreversibly inhibits Thrombin/Kallikrein.

## Workflow

- Preparation: Aliquot your lysate into 3 reaction tubes.
- Pre-Incubation (15 min at RT):
  - Tube 1 (Total Activity): Lysate + Buffer.
  - Tube 2 (Serine Only): Lysate + E-64. (Inhibits background Cathepsins).[1]
  - Tube 3 (Background/Blank): Lysate + AEBSF + E-64. (Inhibits everything).
- Reaction: Add Z-Gly-**Pro-Arg-AMC** (50  $\mu$ M final) to all tubes.
- Measurement: Monitor Fluorescence (Ex 380 nm / Em 460 nm) kinetically for 30–60 minutes.

## Data Analysis Logic

- True Serine Protease Activity = (Slope of Tube 2) - (Slope of Tube 3).
- Cysteine Protease Contamination = (Slope of Tube 1) - (Slope of Tube 2).

- If (Slope Tube 1)  $\approx$  (Slope Tube 2), your assay is specific.
- If (Slope Tube 1)  $\gg$  (Slope Tube 2), you have significant Cathepsin interference.

## Decision Logic Diagram

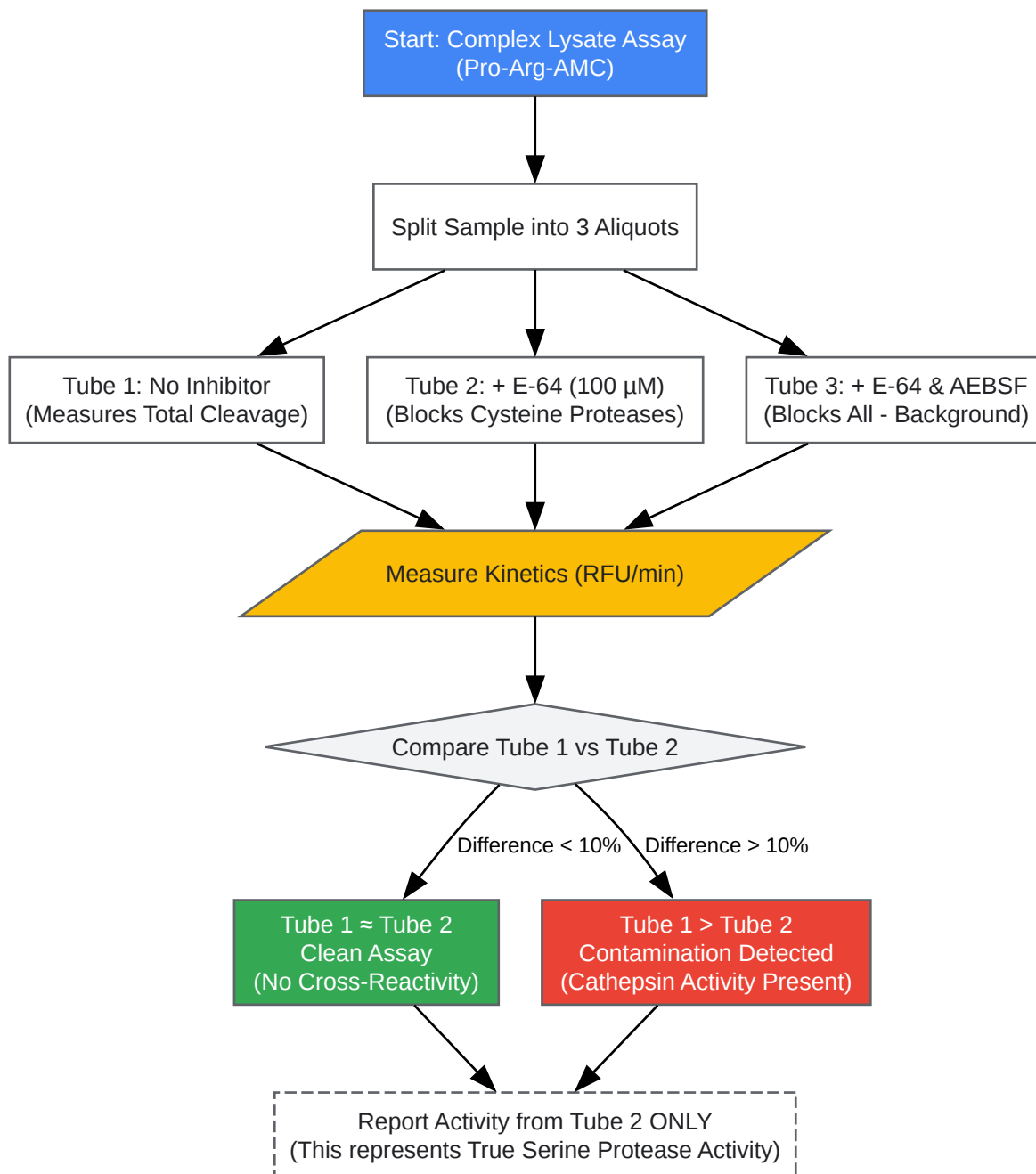

[Click to download full resolution via product page](#)

Figure 2: The Inhibitor Suppression Check (ISC) workflow. This decision tree ensures that reported activity is derived solely from the intended serine protease target.

## References

- Substrate Specificity of Thrombin and Factor Xa. Harris, J.L., et al. "Rapid and general profiling of protease specificity by using combinatorial fluorogenic substrate libraries." Proceedings of the National Academy of Sciences, 2000.
- Cathepsin K Substrate Specificity. Lecaille, F., et al. "Specific cleavage of Z-Gly-**Pro-Arg-AMC** by Cathepsin K." Chemical Reviews (via MedChemExpress Product Data).
- Cross-Reactivity of Cathepsin L. Stack, C.M., et al. "Substrate Specificity of Cysteine Proteases Beyond the S2 Pocket: Mutagenesis and Molecular Dynamics Investigation of Fasciola hepatica Cathepsins L." Frontiers in Cellular and Infection Microbiology, 2018.
- Cathepsin B Specificity and Inhibitors. Hook, V., et al.[2] "Distinct Cleavage Properties of Cathepsin B Compared to Cysteine Cathepsins Enable the Design and Validation of a Specific Substrate for Cathepsin B over a Broad pH Range." [3][4] Biochemistry, 2023.[5]
- General Protease Assay Protocols. Sigma-Aldrich Technical Bulletin. "Fluorometric detection of Z-Gly-**Pro-Arg-AMC** cleavage."

### Need Custom Synthesis?

BenchChem offers custom synthesis for rare earth carbides and specific isotopic labeling.

Email: [info@benchchem.com](mailto:info@benchchem.com) or [Request Quote Online](#).

## Sources

- [1. researchgate.net \[researchgate.net\]](#)
- [2. mdpi.com \[mdpi.com\]](#)
- [3. figshare.com \[figshare.com\]](#)
- [4. researchgate.net \[researchgate.net\]](#)
- [5. escholarship.org \[escholarship.org\]](#)

- To cite this document: BenchChem. [Technical Guide: Mitigating Cysteine Protease Cross-Reactivity in Pro-Arg-AMC Assays]. BenchChem, [2026]. [Online PDF]. Available at: [<https://www.benchchem.com/product/b1344021/docs#technical-guide-mitigating-cysteine-protease-cross-reactivity-in-pro-arg-amc-assays>]

---

### Disclaimer & Data Validity:

The information provided in this document is for Research Use Only (RUO) and is strictly not intended for diagnostic or therapeutic procedures. While BenchChem strives to provide accurate protocols, we make no warranties, express or implied, regarding the fitness of this product for every specific experimental setup.

**Technical Support:** The protocols provided are for reference purposes. Unsure if this reagent suits your experiment?

**Need Industrial/Bulk Grade?** [Request Custom Synthesis Quote](#)

## BenchChem

Our mission is to be the trusted global source of essential and advanced chemicals, empowering scientists and researchers to drive progress in science and industry.

### Contact

Address: 3281 E Guasti Rd  
Ontario, CA 91761, United States  
Phone: (601) 213-4426  
Email: [info@benchchem.com](mailto:info@benchchem.com)

[Contact our Ph.D. Support Team for a compatibility check](#)