

# Introduction: Deciphering Molecular Structure Through Vibrational Spectroscopy

**Author:** BenchChem Technical Support Team. **Date:** May 2026

## Compound of Interest

Compound Name: *1-Benzylpiperidine-3-carbonitrile*

CAS No.: 91820-96-1

Cat. No.: B1344618

[Get Quote](#)

Infrared (IR) spectroscopy stands as a cornerstone analytical technique in modern chemistry, offering a rapid, non-destructive method for identifying functional groups and elucidating molecular structures. By measuring the interaction of infrared radiation with a molecule, we can probe the discrete vibrational energy levels of its constituent bonds. Each functional group—be it a nitrile, an amine, or an aromatic ring—absorbs IR radiation at characteristic frequencies, producing a unique spectral fingerprint. This guide provides a comprehensive analysis of the expected IR spectrum of **1-Benzylpiperidine-3-carbonitrile**, a molecule of interest in synthetic and medicinal chemistry. We will dissect its structure to predict its IR absorption bands, explain the rationale behind these assignments based on fundamental principles, and provide a robust experimental protocol for acquiring high-quality spectral data. This document is intended for researchers and drug development professionals who rely on precise structural characterization to advance their scientific objectives.

## Molecular Architecture and Key Vibrational Modes

**1-Benzylpiperidine-3-carbonitrile** is a multifaceted molecule comprising three key structural motifs: a saturated piperidine ring, a benzyl group, and a nitrile functional group. The vibrational

characteristics of each component contribute to the overall complexity and information-rich nature of its IR spectrum.

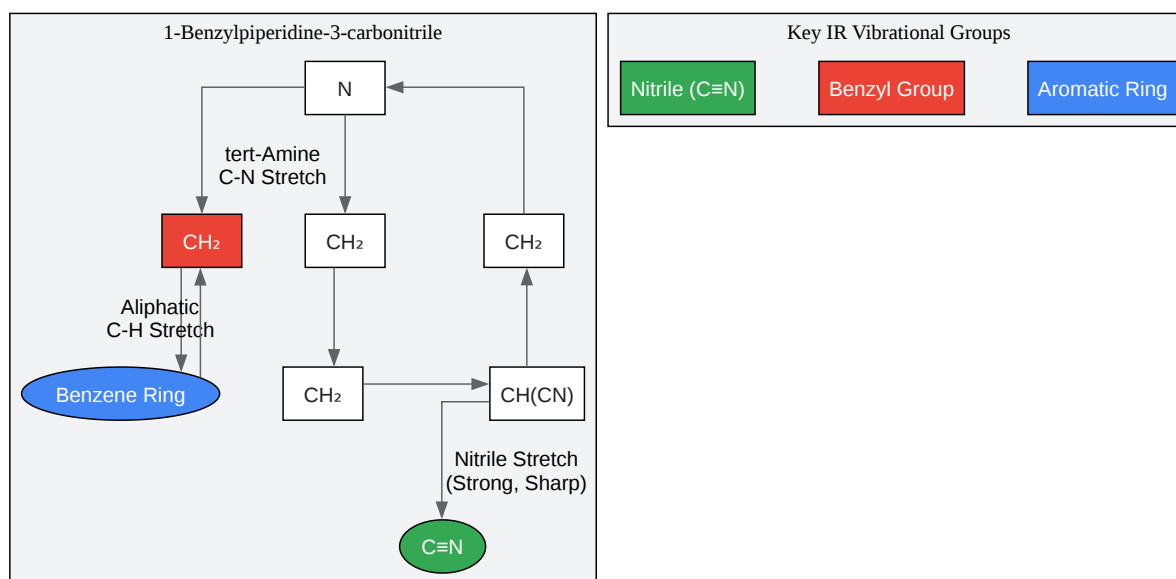

[Click to download full resolution via product page](#)

Caption: Molecular structure highlighting key functional groups.

## Interpreting the Spectrum: A Region-by-Region Analysis

The IR spectrum of **1-Benzylpiperidine-3-carbonitrile** can be logically divided into the functional group region ( $>1500\text{ cm}^{-1}$ ) and the fingerprint region ( $<1500\text{ cm}^{-1}$ ). The former is

characterized by stretches of specific bonds, while the latter contains complex vibrations, including bending and rocking motions, that are unique to the molecule as a whole.

## The Nitrile ( $C\equiv N$ ) Stretching Vibration: A Definitive Marker

The most unambiguous feature in the spectrum is the stretching vibration of the carbon-nitrogen triple bond ( $C\equiv N$ ). Due to the bond's high strength and the significant change in dipole moment during vibration, this absorption is typically sharp and strong. For saturated nitriles, where the nitrile is attached to an  $sp^3$ -hybridized carbon as it is in this molecule, the peak is expected to appear in the  $2260\text{-}2240\text{ cm}^{-1}$  range.[1][2] Its presence is a primary confirmation of the molecule's identity. The intensity of this peak can be influenced by the local electrostatic environment.[3][4]

## C-H Stretching Vibrations: Distinguishing Aromatic and Aliphatic Moieties

The region between  $3100$  and  $2800\text{ cm}^{-1}$  is dominated by C-H stretching vibrations. A key diagnostic step is to use the  $3000\text{ cm}^{-1}$  mark as a dividing line.

- Aromatic C-H Stretch ( $>3000\text{ cm}^{-1}$ ): The  $sp^2$  C-H bonds of the monosubstituted benzene ring will produce weak to medium intensity absorptions just above  $3000\text{ cm}^{-1}$ , typically around  $3100\text{-}3030\text{ cm}^{-1}$ . [5][6]
- Aliphatic C-H Stretch ( $<3000\text{ cm}^{-1}$ ): The  $sp^3$  C-H bonds in the piperidine ring and the benzylic methylene ( $-\text{CH}_2-$ ) bridge will give rise to stronger, more complex absorptions just below  $3000\text{ cm}^{-1}$ , generally in the  $2950\text{-}2850\text{ cm}^{-1}$  range. [2][7]

## The Benzene Ring: Aromatic Overtones and Bending Vibrations

The presence of the monosubstituted benzyl group provides several characteristic signals.

- C=C Ring Stretching: Complex in-plane C=C stretching vibrations within the aromatic ring result in a series of medium-intensity peaks between  $1600\text{ cm}^{-1}$  and  $1450\text{ cm}^{-1}$ . [6][8]

- Out-of-Plane (OOP) C-H Bending: The substitution pattern on a benzene ring strongly influences the C-H out-of-plane bending vibrations. For a monosubstituted ring, two strong bands are expected. One appears between 770-710  $\text{cm}^{-1}$  and another, a ring bend, appears near 690  $\text{cm}^{-1}$ .<sup>[9]</sup> The presence and position of these bands are highly indicative of the monosubstituted pattern.<sup>[5][9]</sup>

## The Fingerprint Region: Piperidine and C-N Vibrations

The region below 1500  $\text{cm}^{-1}$  is dense with various bending (scissoring, rocking, wagging) and stretching vibrations.

- CH<sub>2</sub> Scissoring: The methylene groups of the piperidine ring will exhibit a characteristic scissoring vibration around 1470-1450  $\text{cm}^{-1}$ .<sup>[2]</sup>
- C-N Stretching: The stretching vibration of the tertiary amine's C-N bonds (both within the ring and to the benzyl group) is expected in the 1250-1020  $\text{cm}^{-1}$  range. These peaks are typically of medium to weak intensity.

## Summary of Predicted IR Absorptions

The following table summarizes the expected characteristic infrared absorption bands for **1-Benzylpiperidine-3-carbonitrile**, providing a quick reference for spectral interpretation.

Wavenumber Range (cm <sup>-1</sup> )	Functional Group & Vibration Mode	Expected Intensity
3100 - 3030	Aromatic C-H Stretch	Weak to Medium
2950 - 2850	Aliphatic (CH <sub>2</sub> , CH) C-H Stretch	Medium to Strong
2260 - 2240	Nitrile (C≡N) Stretch	Strong, Sharp
1600 - 1450	Aromatic C=C Ring Stretch	Medium
1470 - 1450	Aliphatic CH <sub>2</sub> Scissoring	Medium
770 - 710	Aromatic C-H Out-of-Plane Bend	Strong
~690	Aromatic Ring Bend (Monosubstituted)	Strong

## Experimental Protocol: Acquiring the IR Spectrum via ATR-FTIR

To ensure high-quality, reproducible data, Attenuated Total Reflectance (ATR) coupled with Fourier Transform Infrared (FTIR) spectroscopy is the recommended method. This technique requires minimal sample preparation and is suitable for solid or liquid samples.

Objective: To obtain the infrared spectrum of **1-Benzylpiperidine-3-carbonitrile** in the 4000-400 cm<sup>-1</sup> range.

Apparatus:

- FTIR Spectrometer (e.g., Nicolet, PerkinElmer, Shimadzu)
- ATR accessory with a diamond or germanium crystal

Procedure:

- Instrument Preparation: Ensure the spectrometer is powered on and has reached thermal equilibrium as per the manufacturer's guidelines.

- Background Scan:
  - Clean the ATR crystal surface meticulously with a suitable solvent (e.g., isopropanol) and a soft, lint-free wipe. Allow the solvent to evaporate completely.
  - Acquire a background spectrum. This is a crucial self-validating step that measures the ambient atmosphere (H<sub>2</sub>O, CO<sub>2</sub>) and the instrument's optical bench, which will be subtracted from the sample spectrum.
- Sample Application:
  - Place a small amount (typically a few milligrams for a solid or a single drop for a liquid) of **1-Benzylpiperidine-3-carbonitrile** directly onto the center of the ATR crystal.
  - If the sample is a solid, use the ATR's pressure clamp to ensure firm and even contact between the sample and the crystal surface. Consistent pressure is key to reproducibility.
- Sample Spectrum Acquisition:
  - Collect the sample spectrum. Standard parameters often involve co-adding 16 to 32 scans at a resolution of 4 cm<sup>-1</sup> to achieve an excellent signal-to-noise ratio.
- Data Processing and Cleaning:
  - The instrument software will automatically ratio the sample scan against the background scan to produce the final absorbance or transmittance spectrum.
  - Clean the ATR crystal thoroughly with a solvent to remove all traces of the sample. Verify cleanliness by collecting a new scan and ensuring it matches the original background.

Caption: ATR-FTIR experimental workflow.

## Conclusion

The infrared spectrum of **1-Benzylpiperidine-3-carbonitrile** is predicted to exhibit a rich set of absorption bands that are highly characteristic of its molecular structure. The definitive sharp peak of the nitrile group around 2250 cm<sup>-1</sup>, combined with the distinct patterns of aromatic and aliphatic C-H stretches and the strong out-of-plane bending bands confirming a

monosubstituted benzene ring, provides a powerful and unique fingerprint for its identification. By following the detailed experimental protocol, researchers can reliably obtain high-quality spectra to confirm the synthesis, assess the purity, and ensure the structural integrity of this important chemical compound.

## References

- Google Patents. (n.d.). CN105622444A - Preparation method for 1-benzyl-3-piperidone hydrochloride.
- Reyes-Parada, M., et al. (2025). Design, Synthesis, and Evaluation of 1-Benzylpiperidine and 1-Benzoylpiperidine Derivatives as Dual-Target Inhibitors of Acetylcholinesterase and Serotonin Transporter for Alzheimer's Disease. PMC - PubMed Central.
- NIST. (n.d.). Piperidine. NIST Chemistry WebBook.
- ChemicalBook. (n.d.). 4-Benzylpiperidine(31252-42-3) IR Spectrum.
- Smith, B. C. (2016). Distinguishing Structural Isomers: Mono- and Disubstituted Benzene Rings. Spectroscopy Online.
- ResearchGate. (2025). Molecular structure and vibrational spectra of piperidine and 4-methylpiperidine by density functional theory and ab initio Hartree–Fock calculations.
- Smith, B. C. (2019). Organic Nitrogen Compounds IV: Nitriles. Spectroscopy Online.
- Chemistry LibreTexts. (2024). 12.8: Infrared Spectra of Some Common Functional Groups.
- MDPI. (n.d.). Piperidine Derivatives: Recent Advances in Synthesis and Pharmacological Applications.
- Chemistry LibreTexts. (2020). 11.5: Infrared Spectra of Some Common Functional Groups.
- Google Patents. (n.d.). CN102351783B - The synthetic method of 1-benzyl-3-piperidone hydrochloride.
- ACS Publications. (2016). Correlating Nitrile IR Frequencies to Local Electrostatics Quantifies Noncovalent Interactions of Peptides and Proteins. The Journal of Physical Chemistry B.
- ResearchGate. (2024). (PDF) Characterization of monosubstituted benzene ices.
- OpenStax. (2023). 15.7 Spectroscopy of Aromatic Compounds. Organic Chemistry.
- RSC Publishing. (2021). IR linewidth and intensity amplifications of nitrile vibrations report nuclear-electronic couplings and associated structural heterogeneity in radical anions.
- PubChem. (n.d.). 4-Anilino-1-benzylpiperidine-4-carbonitrile.
- ChemicalBook. (n.d.). Piperidine(110-89-4)IR1.
- ChemRxiv. (n.d.). Nitrile IR intensities characterize electric fields and hydrogen bonding in protic, aprotic, and protein environments.
- ResearchGate. (2025). A Facile Synthesis of 3-(Substituted benzyl)piperidines.

- RSC Medicinal Chemistry. (2022). Exploration of piperidine 3D fragment chemical space: synthesis and 3D shape analysis of fragments derived from 20 regio.
- Chemistry LibreTexts. (2019). 18.8: Spectral Characteristics of the Benzene Ring.
- Organic Syntheses. (n.d.). 1-benzylpiperazine.
- BLD Pharm. (n.d.). 153931-24-9|3-Amino-**1-benzylpiperidine-3-carbonitrile**.

### Need Custom Synthesis?

BenchChem offers custom synthesis for rare earth carbides and specific isotopic labeling.

Email: [info@benchchem.com](mailto:info@benchchem.com) or [Request Quote Online](#).

## Sources

1. [spectroscopyonline.com](https://www.spectroscopyonline.com) [[spectroscopyonline.com](https://www.spectroscopyonline.com)]
  2. [chem.libretexts.org](https://chem.libretexts.org) [[chem.libretexts.org](https://chem.libretexts.org)]
  3. [pubs.acs.org](https://pubs.acs.org) [[pubs.acs.org](https://pubs.acs.org)]
  4. [chemrxiv.org](https://chemrxiv.org) [[chemrxiv.org](https://chemrxiv.org)]
  5. [chem.libretexts.org](https://chem.libretexts.org) [[chem.libretexts.org](https://chem.libretexts.org)]
  6. [chem.libretexts.org](https://chem.libretexts.org) [[chem.libretexts.org](https://chem.libretexts.org)]
  7. Design, Synthesis, and Evaluation of 1-Benzylpiperidine and 1-Benzoylpiperidine Derivatives as Dual-Target Inhibitors of Acetylcholinesterase and Serotonin Transporter for Alzheimer's Disease - PMC [[pmc.ncbi.nlm.nih.gov](https://pubmed.ncbi.nlm.nih.gov)]
  8. 15.7 Spectroscopy of Aromatic Compounds - Organic Chemistry | OpenStax [[openstax.org](https://openstax.org)]
  9. [spectroscopyonline.com](https://www.spectroscopyonline.com) [[spectroscopyonline.com](https://www.spectroscopyonline.com)]
- To cite this document: BenchChem. [Introduction: Deciphering Molecular Structure Through Vibrational Spectroscopy]. BenchChem, [2026]. [Online PDF]. Available at: [<https://www.benchchem.com/product/b1344618/docs#introduction-deciphering-molecular-structure-through-vibrational-spectroscopy>]

---

### Disclaimer & Data Validity:

The information provided in this document is for Research Use Only (RUO) and is strictly not intended for diagnostic or therapeutic procedures. While BenchChem strives to provide accurate protocols, we make no warranties, express or implied, regarding the fitness of this product for every specific experimental setup.

**Technical Support:** The protocols provided are for reference purposes. Unsure if this reagent suits your experiment?

**Need Industrial/Bulk Grade?** [Request Custom Synthesis Quote](#)

## BenchChem

Our mission is to be the trusted global source of essential and advanced chemicals, empowering scientists and researchers to drive progress in science and industry.

### Contact

Address: 3281 E Guasti Rd  
Ontario, CA 91761, United States  
Phone: (601) 213-4426  
Email: [info@benchchem.com](mailto:info@benchchem.com)

[Contact our Ph.D. Support Team for a compatibility check](#)