

FTIR Characteristic Peaks of Acetylhydrazide Functional Groups

Author: BenchChem Technical Support Team. **Date:** May 2026

Compound of Interest

Compound Name: 4-(2-Acetylhydrazino)-4-oxobutanoic acid
CAS No.: 257885-34-0
Cat. No.: B1344421

[Get Quote](#)

Executive Summary: The Acetylhydrazide Motif

The acetylhydrazide functional group (

) is a critical pharmacophore in medicinal chemistry, serving as the core structure for antitubercular drugs like Isoniazid and a versatile intermediate in the synthesis of heterocyclic compounds (e.g., 1,2,4-triazoles).

Unlike simple amides or carboxylic acids, the acetylhydrazide moiety possesses a unique "dual-amine" architecture coupled with a carbonyl system. This results in a complex vibrational signature characterized by Amide I/II coupling, N-H scissoring, and the often-overlooked N-N stretching mode.

This guide provides a definitive spectral analysis of acetylhydrazide, objectively comparing it against common alternatives (amides, carboxylic acids) to ensure precise structural elucidation.

Molecular Architecture & Vibrational Logic

To interpret the FTIR spectrum accurately, one must understand the molecular geometry. Acetylhydrazide exists predominantly in the trans-syn conformation (Badawi, 2007).

- Trans: The bond of the secondary amine is trans to the bond.
- Syn: The terminal moiety is syn to the bond.

This conformation dictates the dipole moments and, consequently, the intensity of the IR bands.

Graphviz Diagram: Spectral Assignment Logic

The following diagram illustrates the logical flow for assigning characteristic peaks based on the vibrational modes of the acetylhydrazide structure.

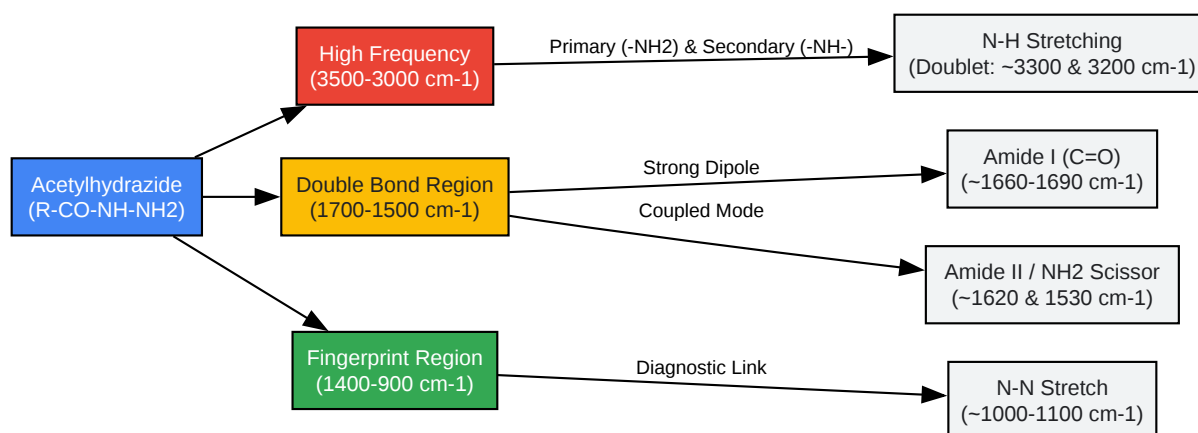

[Click to download full resolution via product page](#)

Figure 1: Logical flow for decomposing the acetylhydrazide IR spectrum into its constituent vibrational modes.

Characteristic Spectral Fingerprint

The following table synthesizes experimental data (KBr and ATR) for the acetylhydrazide functional group.

Table 1: Primary Vibrational Assignments for Acetylhydrazide

Functional Group Mode	Wavenumber ()	Intensity	Description & Causality
N-H Stretching	3350 – 3150	Medium/Strong	<p>Doublet or Multiplet. The terminal group exhibits asymmetric (~3350) and symmetric (~3200) stretching. The secondary stretch often overlaps here, creating a complex band structure distinct from the single band of secondary amides.</p>
C=O Stretch (Amide I)	1690 – 1660	Very Strong	<p>Diagnostic Peak. Lower frequency than esters/acids due to resonance (). The hydrazide nitrogen is electron-donating, reducing the bond order.</p>
N-H Bending ()	1630 – 1610	Medium	<p>Scissoring. Specific to the terminal primary amine. Often appears as a shoulder on the Amide I band.</p>
Amide II (Bend)	1550 – 1520	Medium/Strong	<p>Coupled Mode. A combination of in-plane bending and</p>

stretching. Crucial for distinguishing from ketones (which lack this band).

C-N Stretch

1300 – 1200

Medium

The bond connecting the carbonyl carbon to the hydrazide nitrogen.

N-N Stretch

1100 – 1000

Weak/Medium

The "Hidden" Identifier. A unique feature of hydrazides/hydrazines, absent in amides. Often found near 1030-1050

“

Expert Insight: In solid-state samples (KBr pellet), hydrogen bonding is extensive, causing the N-H and C=O bands to shift to lower frequencies and broaden. In dilute solution (e.g.,

), these bands sharpen and shift to higher frequencies (C=O > 1700

).

Comparative Analysis: Distinguishing Alternatives

In drug development, acetylhydrazides are often synthesized from esters or carboxylic acids. Monitoring this conversion requires distinguishing the product from the starting material.

Table 2: Comparative Spectral Markers

Feature	Acetylhydrazide ()	Carboxylic Acid ()	Primary Amide ()	Ester ()
C=O Position	~1660-1690	~1710	~1650-1690	~1735-1750
High Frequency	Sharp N-H doublet (3150-3350)	Very Broad O-H (2500-3300)	Sharp N-H doublet (3150-3400)	None (unless alcohol impurity)
Fingerprint	N-N stretch (~1050)	C-O stretch (~1250)	No N-N stretch	C-O-C stretch (1000-1300)
Key Distinction	N-N band + Amide I/II	Broad O-H "fermi resonance"	Lack of N-N band	High freq C=O[1] + No N-H

Critical Analysis:

- Vs. Carboxylic Acids: The most obvious difference is the disappearance of the massive, broad O-H stretch of the acid and the appearance of the sharper N-H bands. The C=O also shifts to a lower wavenumber.
- Vs. Primary Amides: This is the hardest distinction. Both have Amide I/II and N-H doublets. You must look for the N-N stretching vibration around 1000-1100 to confirm the hydrazide.

Experimental Protocol: Validated Workflow

To ensure reproducibility, the choice between Attenuated Total Reflectance (ATR) and Transmission (KBr) is critical.

Graphviz Diagram: Experimental Decision Matrix

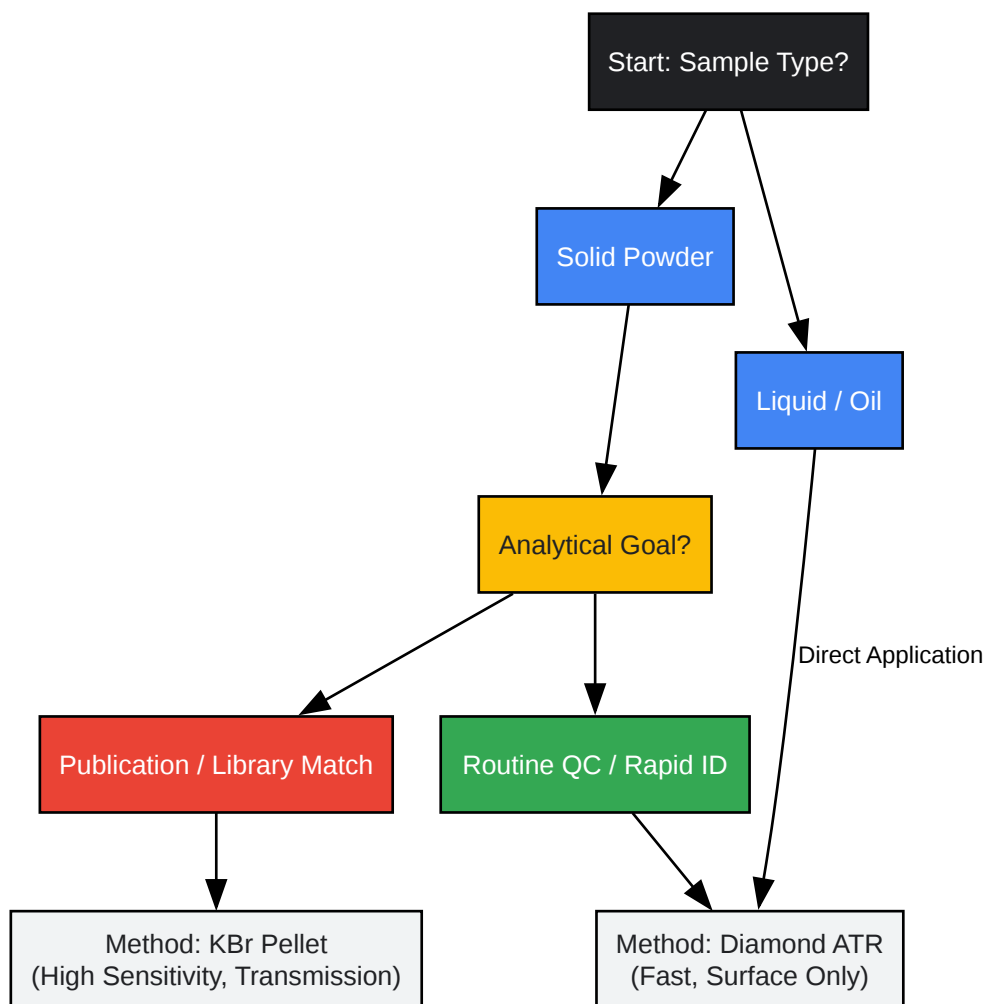

[Click to download full resolution via product page](#)

Figure 2: Decision matrix for selecting the appropriate FTIR sampling technique.

Protocol A: Diamond ATR (Recommended for Routine Analysis)

Rationale: Hydrazides are often crystalline solids. ATR requires no sample prep, minimizing moisture absorption (which interferes with N-H/O-H regions).

- System Check: Ensure the background spectrum (air) is clean. Clean the diamond crystal with isopropanol.
- Sample Loading: Place ~2-5 mg of the acetylhydrazide sample onto the center of the crystal.

- Contact: Lower the pressure arm until the force gauge reads the optimal value (typically ~80-100 N). Crucial: Poor contact results in weak peaks, especially in the high-wavenumber N-H region.
- Acquisition: Scan range 4000–400

, 4

resolution, 16-32 scans.
- Post-Processing: Apply "ATR Correction" (if quantitative comparison to transmission libraries is needed) to account for depth of penetration dependence on wavelength.

Protocol B: KBr Pellet (Recommended for Structural Validation)

Rationale: Provides higher spectral resolution and eliminates the "penetration depth" artifact of ATR. Essential for detecting weak bands like the N-N stretch.

- Ratio: Mix sample with optical grade KBr powder in a 1:100 ratio (1 mg sample : 100 mg KBr).
- Grinding: Grind in an agate mortar until a fine, uniform powder is achieved. Warning: Do not over-grind if the sample is polymorphic, as heat/pressure can induce phase changes.
- Pressing: Press at 8-10 tons for 1-2 minutes under vacuum (to remove water) to form a transparent disc.
- Measurement: Measure immediately to prevent hygroscopic water uptake (which would manifest as a broad band at 3400

, obscuring the N-H doublet).

References

- Badawi, H. M. (2007).^{[1][2][3][4]} Vibrational spectra and analysis of acetohydrazide

- . Spectrochimica Acta Part A: Molecular and Biomolecular Spectroscopy, 67(3-4), 592-597. [2] [Link](#)
- Silverstein, R. M., Webster, F. X., & Kiemle, D. J. (2005). Spectrometric Identification of Organic Compounds (7th ed.). John Wiley & Sons. (Standard text for Amide I/II assignments).
- Sigma-Aldrich. (n.d.). Acetylhydrazide ATR-IR Spectrum. SpectraBase. [Link](#)
- Sangeetha, et al. (2015). Structural stability and vibrational assignment of Phenoxyacetohydrazide. International Journal of Research – Granthaalayah, 3(7).[1] [Link](#)

Need Custom Synthesis?

BenchChem offers custom synthesis for rare earth carbides and specific isotopic labeling.

Email: info@benchchem.com or [Request Quote Online](#).

Sources

- 1. granthaalayahpublication.org [granthaalayahpublication.org]
- 2. researchgate.net [researchgate.net]
- 3. pubs.acs.org [pubs.acs.org]
- 4. sciforum.net [sciforum.net]
- To cite this document: BenchChem. [FTIR Characteristic Peaks of Acetylhydrazide Functional Groups]. BenchChem, [2026]. [Online PDF]. Available at: [<https://www.benchchem.com/product/b1344421/docs#ftir-characteristic-peaks-of-acetylhydrazide-functional-groups>]

Disclaimer & Data Validity:

The information provided in this document is for Research Use Only (RUO) and is strictly not intended for diagnostic or therapeutic procedures. While BenchChem strives to provide accurate protocols, we make no warranties, express or implied, regarding the fitness of this product for every specific experimental setup.

Technical Support: The protocols provided are for reference purposes. Unsure if this reagent suits your experiment?

Need Industrial/Bulk Grade? [Request Custom Synthesis Quote](#)

BenchChem

Our mission is to be the trusted global source of essential and advanced chemicals, empowering scientists and researchers to drive progress in science and industry.

Contact

Address: 3281 E Guasti Rd
Ontario, CA 91761, United States
Phone: (601) 213-4426
Email: info@benchchem.com

[Contact our Ph.D. Support Team for a compatibility check](#)