

Technical Support Center: High-Resolution HPLC Separation of Erythromycin & Impurities

Author: BenchChem Technical Support Team. **Date:** May 2026

Compound of Interest

Compound Name: *Erythromycin A 9,11-Imino Ether*

Cat. No.: *B13438724*

[Get Quote](#)

Status: Operational Lead Scientist: Dr. Aris Thorne, Senior Application Scientist Subject: Troubleshooting Co-elution, Peak Tailing, and Sensitivity in Macrolide Analysis

Introduction: The Macrolide Challenge

Welcome to the technical support hub for Erythromycin analysis. If you are here, you are likely facing one of three specific failures:

- Co-elution: Erythromycin A is merging with Erythromycin B or the N-oxide impurity.
- Peak Tailing: Your asymmetry factor () is > 1.5 , destroying integration accuracy.
- Baseline Drift: You are detecting at low UV (205–215 nm), and the baseline is unstable.

Erythromycin is a 14-membered macrocyclic lactone. It is a basic compound (

) with high molecular weight (733.9 Da) and lacks a strong chromophore. These physicochemical properties create a "perfect storm" for HPLC difficulties. This guide ignores

generic advice and focuses on the specific mechanisms required to separate this molecule from its structurally similar impurities (A, B, C, D, E, and F).

Part 1: The Triage (Quick Diagnostics)

Before altering your method, identify the root cause using this decision matrix.

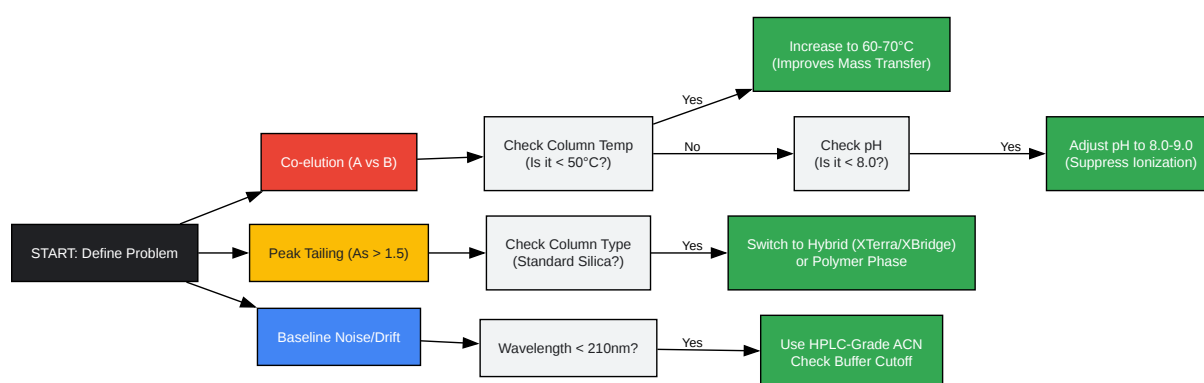

[Click to download full resolution via product page](#)

Figure 1: Diagnostic logic flow for identifying the root cause of Erythromycin separation failures.

Part 2: Resolving Co-eluting Peaks (Erythromycin A & B)

The Issue: Erythromycin A and B differ only by a single hydroxyl group. Under standard acidic conditions (pH 2-4), both are protonated and exhibit similar hydrophobicity, leading to co-elution.

Critical Parameter 1: Temperature (The Kinetic Effect)

Macrolides are large molecules with slow diffusion coefficients. At ambient temperature (25°C), mass transfer between the mobile and stationary phases is slow, resulting in broad peaks that

merge.

- **The Fix:** You must operate at elevated temperatures (60°C – 70°C).
- **Why:** High temperature reduces mobile phase viscosity and increases the diffusion rate of the analyte. This sharpens the peaks significantly, often resolving the "critical pair" (A and B) simply by narrowing their widths.
- **Caution:** Ensure your column is rated for >60°C. Traditional silica columns degrade faster at high temps; hybrid particles (e.g., Waters XTerra, XBridge) are required [1].

Critical Parameter 2: pH (The Selectivity Effect)

Erythromycin has a

of ~8.8 (dimethylamino group).

- **Low pH (< 7):** The molecule is ionized (). [1] It is more polar and elutes faster, but secondary interactions with silanols cause tailing.
- **High pH (> 8):** The molecule is neutral (). It is more hydrophobic and retains longer on the C18 chain. Crucially, the neutral forms of Erythromycin A and B have slightly different hydrophobicities than their ionized forms, improving selectivity ().

Protocol: High-pH Phosphate Buffer Preparation

- **Reagents:** 0.02 M Potassium Dihydrogen Phosphate ().
- **Adjustment:** Adjust pH to 9.0 using dilute Potassium Hydroxide (KOH) or use an ammonium buffer if MS detection is required.
- **Warning:** Do NOT use standard silica columns at pH 9.0; the silica backbone will dissolve. You must use a "Hybrid" (bridged ethyl hybrid) or Polymer-based column [2].

Part 3: Eliminating Peak Tailing

The Issue: "Shark-fin" peaks where the tail drags, making integration of small impurities (like Impurity F) impossible.

The Mechanism: Erythromycin is a base.[2] Standard silica columns have residual silanol groups (

) on the surface. These silanols are acidic (

).

- If you run at pH 7, silanols are deprotonated (

).

- The positively charged Erythromycin (

) interacts ionically with the negative silanol. This is a "secondary retention mechanism" that is slow and causes tailing.[3]

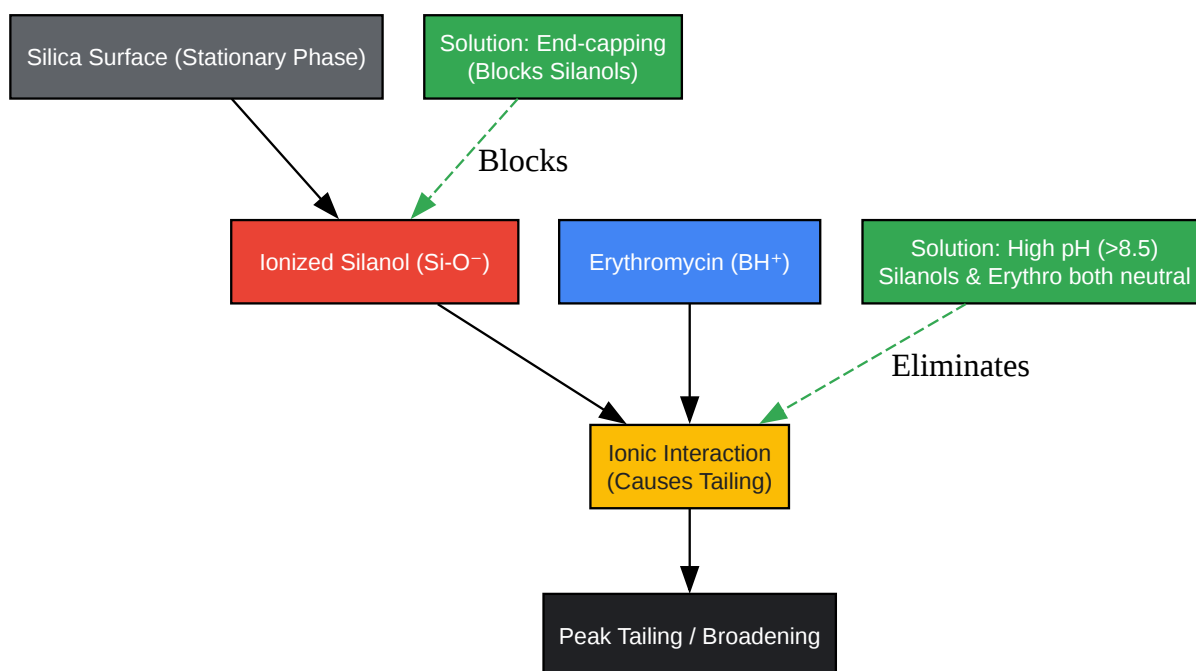

[Click to download full resolution via product page](#)

Figure 2: Mechanism of silanol-induced peak tailing and chemical solutions.

The Solution:

- Hybrid Columns: Use columns like Waters XTerra RP18 or Agilent Zorbax Extend-C18. These are designed to withstand high pH and have reduced silanol activity [3].
- Sacrificial Base (Legacy Method): If you must use a standard column, add Triethylamine (TEA) to the mobile phase. TEA competes for the silanol sites, blocking them from the Erythromycin. Note: This is not recommended for modern methods.

Part 4: Detection & Sensitivity (UV vs. Baseline)

The Issue: Erythromycin has very poor UV absorbance.[4] You must detect at 210 nm or 215 nm (end absorption of the lactone ring). At this wavelength, many solvents absorb light, causing drifting baselines.

Troubleshooting Checklist:

- Solvent Grade: Use only "Gradient Grade" or "Far UV" Acetonitrile. Standard HPLC grade may have impurities that absorb at 210 nm.
- Buffer Choice:
 - Phosphate:[5][6][7][8] Transparent at 215 nm (Good for UV).
 - Acetate/Formate: High UV cutoff (Bad for UV at 215 nm; use only for MS).
- Wavelength Selection:
 - 215 nm: Best balance of signal-to-noise.
 - 205 nm: Higher signal, but much higher noise from solvents.

Summary: Recommended Validated Protocol

Based on the synthesis of USP/EP monographs and modern hybrid particle technology, this is the robust starting point for separating Erythromycin from Impurities B, C, and N-oxide.

Parameter	Specification	Rationale
Column	Waters XTerra RP18 (4.6 x 250 mm, 3.5 µm)	Hybrid particle allows high pH and Temp.
Temperature	65°C (± 2°C)	Critical for sharpening peaks (mass transfer).
Mobile Phase A	0.02 M Phosphate Buffer (pH 9.0)	High pH suppresses ionization (reduces tailing).
Mobile Phase B	Acetonitrile	Lower UV cutoff than Methanol.
Flow Rate	1.0 mL/min	Standard for 4.6 mm ID columns.[6]
Detection	UV @ 215 nm	Optimal sensitivity vs. noise.
Elution	Gradient or Isocratic	Isocratic (approx 40-50% B) often sufficient for A/B split.

Frequently Asked Questions (FAQ)

Q: Can I use a standard C18 column (e.g., µBondapak) for this method? A: Only if you lower the pH to < 7.5 and accept some peak tailing. If you run a standard silica C18 at pH 9.0 and 65°C, you will strip the bonded phase and dissolve the silica within 50-100 injections.

Q: My Erythromycin B peak is still a shoulder on the main peak. A: Decrease the organic modifier (Acetonitrile) by 2-3%. This increases the retention factor (

), giving the column more time to leverage the small selectivity difference. Also, confirm your temperature is actually reaching 65°C (check the column heater block contact).

Q: I see a "ghost peak" eluting late in the run. A: This is likely Erythromycin C or Impurity E, which are more hydrophobic. Ensure your run time is long enough (typically 2.5x the retention time of the main peak) to clear these before the next injection.

References

- Tsuji, K., & Kane, M. P. (1982). Improved high-pressure liquid chromatographic method for the analysis of erythromycin in solid dosage forms. *Journal of Pharmaceutical Sciences*, 71(10), 1160–1164.[9]
- BenchChem Technical Support. (2025). A Comparative Guide to Validated HPLC Methods for the Quantification of Erythromycin A N-oxide.
- Waters Corporation. (n.d.). XTerra Columns: Hybrid Particle Technology for High pH Stability.
- Sielc Technologies. (2018). Separation of Erythromycin ethylsuccinate on Newcrom R1 HPLC column.[10]
- Thermo Fisher Scientific. (n.d.). Forced-degradation Evaluation of Erythromycin by HPLC and Single Quadrupole Mass Spectrometry.

Need Custom Synthesis?

BenchChem offers custom synthesis for rare earth carbides and specific isotopic labeling.

Email: info@benchchem.com or [Request Quote Online](#).

Sources

- [1. Development of an HPLC method for the simultaneous determination of azithromycin, clarithromycin, and erythromycin in wastewater - RSC Advances \(RSC Publishing\) DOI:10.1039/D5RA07172K \[pubs.rsc.org\]](#)
- [2. pdf.benchchem.com \[pdf.benchchem.com\]](#)
- [3. Common Causes Of Peak Tailing in Chromatography - Blogs - News \[alwsci.com\]](#)
- [4. lcms.cz \[lcms.cz\]](#)
- [5. researchgate.net \[researchgate.net\]](#)
- [6. pdf.benchchem.com \[pdf.benchchem.com\]](#)
- [7. researchgate.net \[researchgate.net\]](#)
- [8. ijpsr.com \[ijpsr.com\]](#)
- [9. Improved high-pressure liquid chromatographic method for the analysis of erythromycin in solid dosage forms - PubMed \[pubmed.ncbi.nlm.nih.gov\]](#)

- [10. Separation of Erythromycin ethylsuccinate on Newcrom R1 HPLC column | SIELC Technologies \[sielc.com\]](#)
- To cite this document: BenchChem. [Technical Support Center: High-Resolution HPLC Separation of Erythromycin & Impurities]. BenchChem, [2026]. [Online PDF]. Available at: [<https://www.benchchem.com/product/b13438724/docs#technical-support-center-high-resolution-hplc-separation-of-erythromycin-impurities>]

Disclaimer & Data Validity:

The information provided in this document is for Research Use Only (RUO) and is strictly not intended for diagnostic or therapeutic procedures. While BenchChem strives to provide accurate protocols, we make no warranties, express or implied, regarding the fitness of this product for every specific experimental setup.

Technical Support: The protocols provided are for reference purposes. Unsure if this reagent suits your experiment?

Need Industrial/Bulk Grade? [Request Custom Synthesis Quote](#)

BenchChem

Our mission is to be the trusted global source of essential and advanced chemicals, empowering scientists and researchers to drive progress in science and industry.

Contact

Address: 3281 E Guasti Rd
Ontario, CA 91761, United States
Phone: (601) 213-4426
Email: info@benchchem.com

[Contact our Ph.D. Support Team for a compatibility check](#)