

# Application Notes and Protocols for DY3002 in EGFR-Mutant Cell Lines

**Author:** BenchChem Technical Support Team. **Date:** April 2026

## Compound of Interest

Compound Name: DY3002  
Cat. No.: B13435455

[Get Quote](#)

For Research Use Only.

## Introduction

The Epidermal Growth Factor Receptor (EGFR) is a critical signaling molecule often implicated in the progression of various cancers, particularly non-small cell lung cancer (NSCLC). Mutations in the EGFR gene can lead to its constitutive activation, promoting uncontrolled cell growth and survival. While several generations of EGFR tyrosine kinase inhibitors (TKIs) have been developed, acquired resistance, frequently mediated by the T790M mutation, remains a significant clinical challenge.

**DY3002**, N-(3-((5-chloro-2-(4-((1-morpholino)methyl)phenylamino)-4-pyrimidinyl)amino)phenyl)acrylamide, is a novel, potent, and selective inhibitor of mutant EGFR.<sup>[1][2]</sup> It has been designed to effectively target EGFR harboring activating mutations, including the T790M resistance mutation, while showing significantly less activity against wild-type (WT) EGFR. This selectivity profile suggests a potential for a wider therapeutic window and reduced side effects compared to less selective inhibitors.<sup>[1]</sup>

These application notes provide detailed protocols for researchers, scientists, and drug development professionals to study the effects of **DY3002** on EGFR-mutant cell lines, focusing

on its anti-proliferative activity and its impact on EGFR signaling pathways.

## Mechanism of Action

**DY3002** is an irreversible inhibitor that covalently binds to the cysteine residue at position 797 in the ATP-binding pocket of the EGFR kinase domain. By targeting mutant forms of EGFR, including the T790M "gatekeeper" mutation, **DY3002** effectively blocks the downstream signaling cascades that drive tumor cell proliferation and survival.[1][3] The primary pathways inhibited are the RAS-RAF-MEK-ERK (MAPK) and the PI3K-AKT-mTOR pathways, both of which are crucial for cell cycle progression and the inhibition of apoptosis.

## Data Presentation

The following tables summarize the in vitro efficacy of **DY3002** in comparison to other EGFR inhibitors.

Table 1: In Vitro Kinase Inhibitory Activity of **DY3002** and Reference Compounds.[1]

| Compound    | EGFR <sup>T790M/L858R</sup> IC50 (nM) | Wild-Type EGFR IC50 (nM) | Selectivity Index (WT/T790M) |
|-------------|---------------------------------------|--------------------------|------------------------------|
| DY3002      | 0.71                                  | 448.7                    | 632.0                        |
| Rociletinib | 15.2                                  | 325.4                    | 21.4                         |
| Osimertinib | 11.0                                  | 450.1                    | 40.9                         |

Table 2: Anti-proliferative Activity of **DY3002** in an EGFR-Mutant Cell Line.[1]

| Cell Line | Relevant EGFR Mutation(s) | DY3002 IC50 (µM) |
|-----------|---------------------------|------------------|
| H1975     | L858R, T790M              | 0.037            |

## Mandatory Visualizations

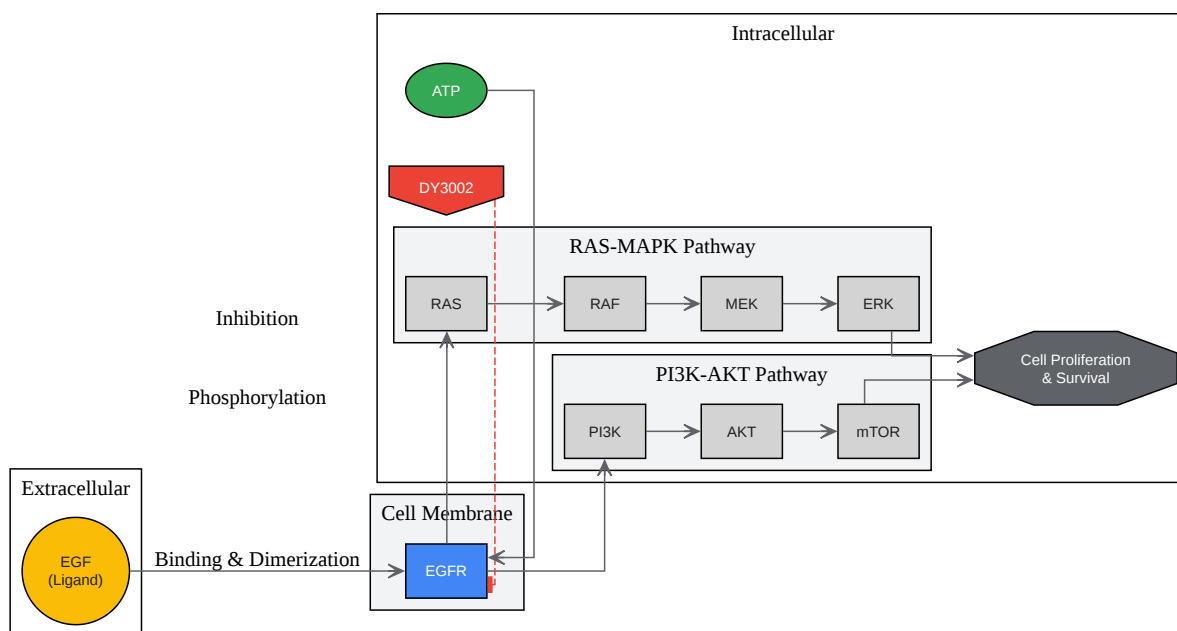

[Click to download full resolution via product page](#)

EGFR Signaling Pathway and **DY3002** Inhibition.

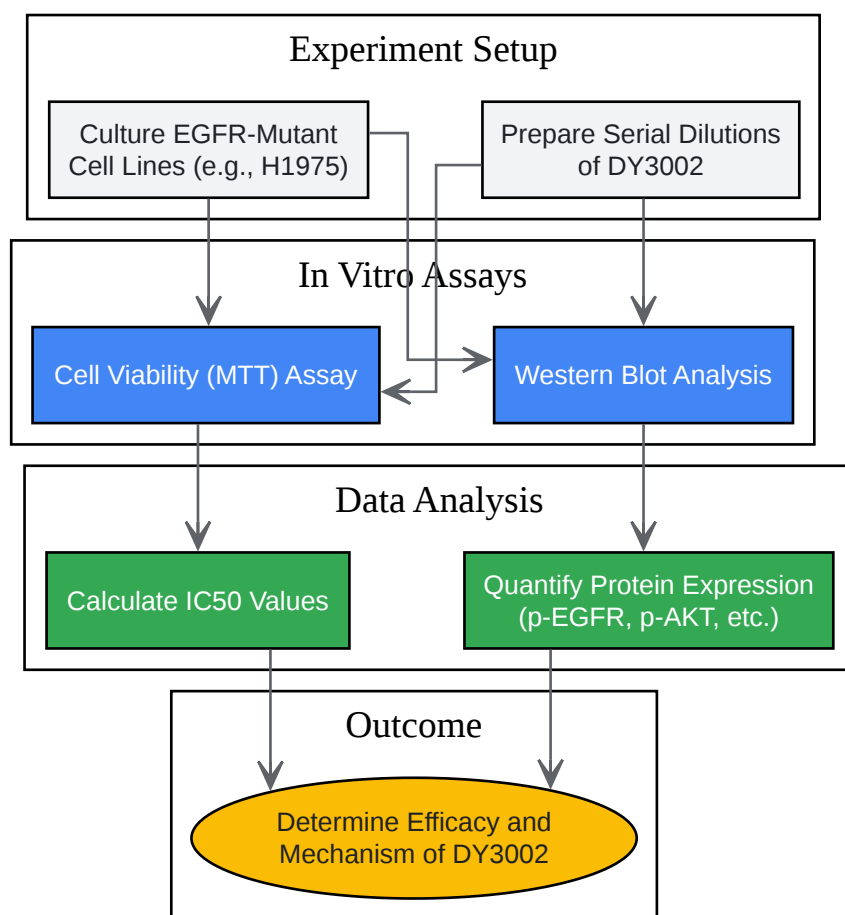

[Click to download full resolution via product page](#)

Experimental Workflow for Evaluating **DY3002**.

## Experimental Protocols

### Protocol 1: Cell Viability (MTT) Assay

This protocol is for determining the half-maximal inhibitory concentration (IC<sub>50</sub>) of **DY3002** in EGFR-mutant cell lines.

Materials:

- EGFR-mutant cell lines (e.g., H1975, PC-9)
- Complete culture medium (e.g., RPMI-1640 with 10% FBS)

- **DY3002**
- DMSO
- MTT (3-(4,5-dimethylthiazol-2-yl)-2,5-diphenyltetrazolium bromide) solution (5 mg/mL in PBS)
- Solubilization solution (e.g., DMSO or 0.01 M HCl in 10% SDS)
- 96-well plates
- Microplate reader

Procedure:

- Cell Seeding:
  - Harvest and count cells, ensuring viability is >90%.
  - Seed cells in a 96-well plate at a density of 5,000-10,000 cells per well in 100  $\mu$ L of complete culture medium.
  - Incubate overnight at 37°C in a humidified 5% CO<sub>2</sub> incubator to allow for cell attachment.
- Compound Treatment:
  - Prepare a stock solution of **DY3002** in DMSO.
  - Perform serial dilutions of **DY3002** in complete culture medium to achieve 2X the final desired concentrations.
  - Include a vehicle control (e.g., 0.1% DMSO in medium) and a no-cell control (medium only).
  - Carefully remove the medium from the wells and add 100  $\mu$ L of the **DY3002** dilutions or control solutions.
  - Incubate for the desired treatment period (e.g., 72 hours).

- MTT Addition and Incubation:
  - After the incubation period, add 10  $\mu$ L of MTT solution (5 mg/mL) to each well.
  - Incubate the plate for 3-4 hours at 37°C until purple formazan crystals are visible.
- Solubilization and Absorbance Measurement:
  - Add 100-150  $\mu$ L of solubilization solution to each well to dissolve the formazan crystals.
  - Mix gently on an orbital shaker for 15 minutes to ensure complete solubilization.
  - Read the absorbance at 570 nm using a microplate reader. A reference wavelength of 630 nm can be used to subtract background absorbance.
- Data Analysis:
  - Subtract the average absorbance of the no-cell control wells from all other values.
  - Calculate the percentage of cell viability for each concentration relative to the vehicle-treated control.
  - Plot the percentage of viability against the log of the **DY3002** concentration and use non-linear regression analysis to determine the IC50 value.

## Protocol 2: Western Blot Analysis of EGFR Signaling

This protocol is to assess the effect of **DY3002** on the phosphorylation status of EGFR and downstream signaling proteins.

Materials:

- EGFR-mutant cell lines
- Complete culture medium
- **DY3002**
- DMSO

- Ice-cold Phosphate-Buffered Saline (PBS)
- RIPA lysis buffer with protease and phosphatase inhibitors
- BCA or Bradford protein assay kit
- Laemmli sample buffer
- SDS-PAGE gels (e.g., 4-12% gradient)
- PVDF or nitrocellulose membranes
- Transfer buffer
- Blocking buffer (e.g., 5% non-fat dry milk or BSA in TBST)
- Primary antibodies (e.g., anti-p-EGFR, anti-EGFR, anti-p-AKT, anti-AKT, anti- $\beta$ -actin)
- HRP-conjugated secondary antibodies
- Enhanced Chemiluminescence (ECL) substrate
- Imaging system

#### Procedure:

- Cell Treatment and Lysis:
  - Seed cells in 6-well plates and grow to 70-80% confluency.
  - Treat cells with various concentrations of **DY3002** (and a vehicle control) for a specified time (e.g., 2-24 hours).
  - After treatment, wash the cells twice with ice-cold PBS.
  - Add 100-200  $\mu$ L of ice-cold RIPA lysis buffer to each well and incubate on ice for 30 minutes.

- Scrape the cells and transfer the lysate to a microcentrifuge tube. Centrifuge at 14,000 x g for 15 minutes at 4°C.
- Collect the supernatant containing the soluble proteins.
- Protein Quantification:
  - Determine the protein concentration of each lysate using a BCA or Bradford assay according to the manufacturer's instructions.
- Sample Preparation and SDS-PAGE:
  - Mix equal amounts of protein (e.g., 20-30 µg) with Laemmli sample buffer and boil at 95-100°C for 5-10 minutes.
  - Load the samples onto an SDS-PAGE gel and run at a constant voltage until the dye front reaches the bottom.
- Protein Transfer:
  - Transfer the separated proteins from the gel to a PVDF membrane using a wet or semi-dry transfer system.
- Immunoblotting:
  - Block the membrane with blocking buffer for 1 hour at room temperature.
  - Incubate the membrane with the primary antibody (e.g., anti-p-EGFR, diluted in blocking buffer) overnight at 4°C.
  - Wash the membrane three times with TBST for 10 minutes each.
  - Incubate with the appropriate HRP-conjugated secondary antibody for 1 hour at room temperature.
  - Wash the membrane again three times with TBST.
- Detection and Analysis:

- Apply ECL substrate to the membrane and capture the chemiluminescent signal using an imaging system.
- Quantify the band intensities using densitometry software. Normalize the phosphoprotein levels to the total protein levels and the loading control (e.g.,  $\beta$ -actin).

### Need Custom Synthesis?

BenchChem offers custom synthesis for rare earth carbides and specific isotopic labeling.

Email: [info@benchchem.com](mailto:info@benchchem.com) or [Request Quote Online](#).

## References

- [1. mdpi.com \[mdpi.com\]](https://www.mdpi.com)
- [2. Novel Selective and Potent EGFR Inhibitor that Overcomes T790M-Mediated Resistance in Non-Small Cell Lung Cancer - PubMed \[pubmed.ncbi.nlm.nih.gov\]](#)
- [3. Novel mutant-selective EGFR kinase inhibitors against EGFR T790M - PMC \[pmc.ncbi.nlm.nih.gov\]](#)
- To cite this document: BenchChem. [Application Notes and Protocols for DY3002 in EGFR-Mutant Cell Lines]. BenchChem, [2026]. [Online PDF]. Available at: [\[https://www.benchchem.com/product/b13435455/docs#application-notes-and-protocols-for-dy3002-in-egfr-mutant-cell-lines\]](https://www.benchchem.com/product/b13435455/docs#application-notes-and-protocols-for-dy3002-in-egfr-mutant-cell-lines)

---

### Disclaimer & Data Validity:

The information provided in this document is for Research Use Only (RUO) and is strictly not intended for diagnostic or therapeutic procedures. While BenchChem strives to provide accurate protocols, we make no warranties, express or implied, regarding the fitness of this product for every specific experimental setup.

**Technical Support:** The protocols provided are for reference purposes. Unsure if this reagent suits your experiment?

**Need Industrial/Bulk Grade?** [Request Custom Synthesis Quote](#)

# BenchChem

Our mission is to be the trusted global source of essential and advanced chemicals, empowering scientists and researchers to drive progress in science and industry.

## Contact

Address: 3281 E Guasti Rd

Ontario, CA 91761, United States

Phone: (601) 213-4426

Email: [info@benchchem.com](mailto:info@benchchem.com)

[Contact our Ph.D. Support Team for a compatibility check](#)