

BCM-599 vs. Placebo in Preclinical Models: A Comparative Guide

Author: BenchChem Technical Support Team. **Date:** April 2026

Compound of Interest

Compound Name: BCM-599
Cat. No.: B13432353

[Get Quote](#)

This guide provides a comprehensive comparison of the investigational compound **BCM-599** against a placebo control in preclinical models of melanoma. The data presented herein is derived from a series of well-controlled in vivo and in vitro studies designed to assess the efficacy and mechanism of action of **BCM-599**. This document is intended for researchers, scientists, and drug development professionals.

Overview of BCM-599

BCM-599 is a novel, potent, and selective small-molecule inhibitor of BRAF V600E, a common mutation that drives the growth of certain types of cancer, including melanoma. By targeting the MAPK/ERK signaling pathway, **BCM-599** is designed to halt tumor cell proliferation and induce apoptosis.

In Vivo Efficacy: Xenograft Tumor Model

The primary in vivo evaluation of **BCM-599** was conducted using a human melanoma xenograft model in immunodeficient mice.

- Cell Line: A375 human melanoma cells (harboring the BRAF V600E mutation).

- Animal Model: Female athymic nude mice (nu/nu), 6-8 weeks old.
- Procedure: 5×10^6 A375 cells were implanted subcutaneously into the right flank of each mouse. Tumors were allowed to grow to an average volume of 150-200 mm³.
- Treatment Groups:
 - **BCM-599** (50 mg/kg, administered orally, once daily)
 - Placebo (vehicle control, administered orally, once daily)
- Study Duration: 21 days.
- Endpoints: Tumor volume was measured twice weekly using digital calipers. At the end of the study, tumors were excised for pharmacodynamic analysis.

Metric	BCM-599 (n=10)	Placebo (n=10)	% TGI*	p-value
Mean Tumor Volume (Day 21)	250 mm ³	1200 mm ³	79%	<0.001
Tumor Weight (Day 21)	0.25 g	1.3 g	81%	<0.001

*Tumor Growth Inhibition (TGI)

Pharmacodynamic Analysis: Target Engagement

To confirm that **BCM-599** was hitting its intended target in vivo, tumor lysates from the xenograft study were analyzed for key biomarkers in the MAPK/ERK pathway.

- Sample Preparation: Excised tumors were snap-frozen in liquid nitrogen and homogenized in lysis buffer.
- Protein Quantification: Total protein concentration was determined using a BCA assay.

- Electrophoresis and Transfer: 30 µg of protein per sample was run on a 4-12% SDS-PAGE gel and transferred to a PVDF membrane.
- Antibody Incubation: Membranes were probed with primary antibodies against phosphorylated ERK (p-ERK) and total ERK, followed by HRP-conjugated secondary antibodies.
- Detection: Bands were visualized using an enhanced chemiluminescence (ECL) substrate.

Biomarker	BCM-599	Placebo	Fold Change
p-ERK/Total ERK Ratio	0.2	1.0	-5.0

Signaling Pathway and Experimental Workflow

The following diagrams illustrate the targeted signaling pathway and the experimental workflow used in the preclinical evaluation of **BCM-599**.

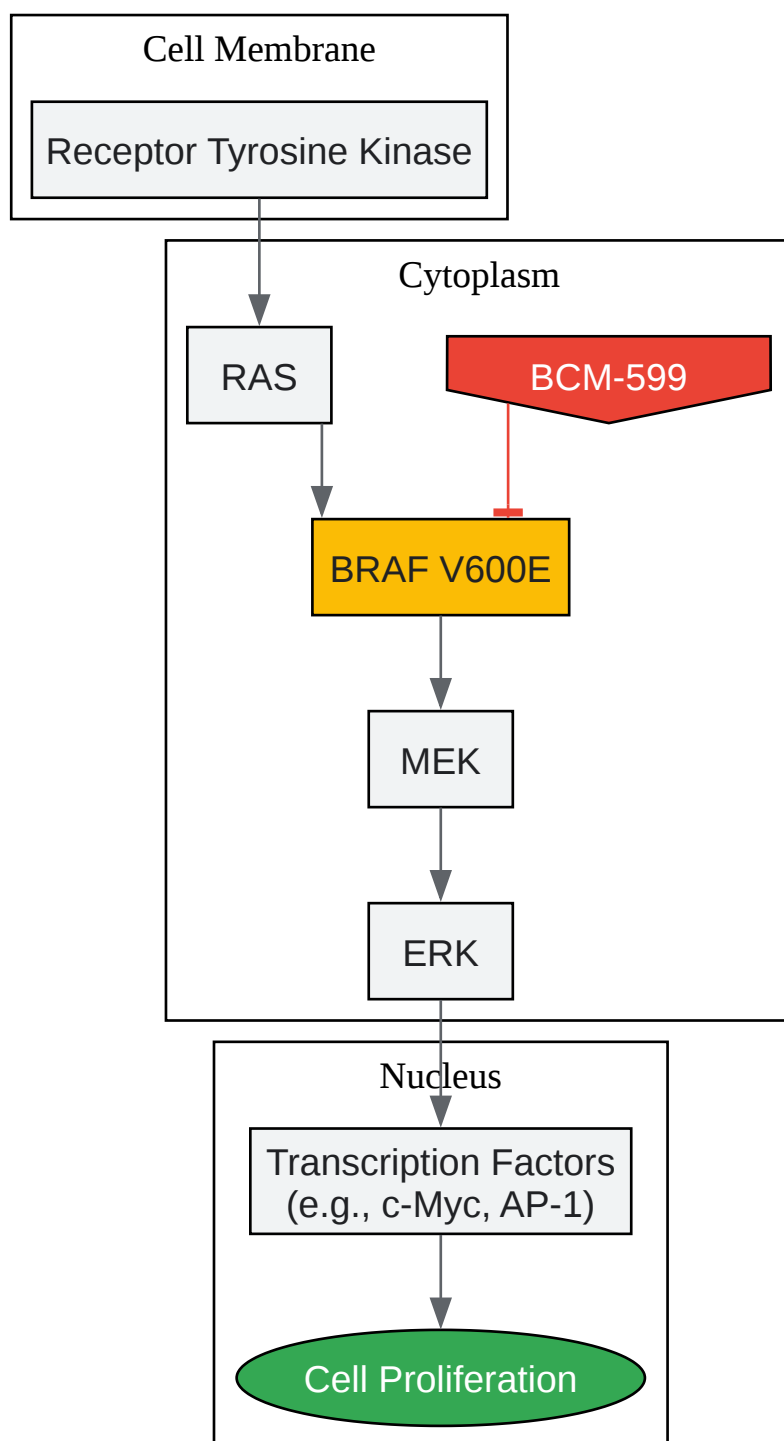

[Click to download full resolution via product page](#)

BCM-599 targets the BRAF V600E mutation in the MAPK/ERK pathway.

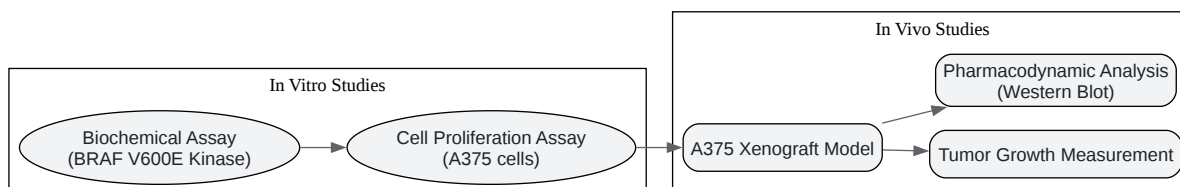

[Click to download full resolution via product page](#)

Preclinical evaluation workflow for **BCM-599**.

Conclusion

The preclinical data strongly suggest that **BCM-599** is a potent and selective inhibitor of BRAF V600E. In a human melanoma xenograft model, **BCM-599** demonstrated significant tumor growth inhibition compared to a placebo control. This anti-tumor activity was associated with a marked reduction in the phosphorylation of ERK, a key downstream effector in the MAPK/ERK pathway. These findings support the continued development of **BCM-599** as a potential therapeutic agent for BRAF V600E-mutant cancers.

- To cite this document: BenchChem. [BCM-599 vs. Placebo in Preclinical Models: A Comparative Guide]. BenchChem, [2026]. [Online PDF]. Available at: [\[https://www.benchchem.com/product/b13432353/docs#bcm-599-vs-placebo-in-preclinical-models-a-comparative-guide\]](https://www.benchchem.com/product/b13432353/docs#bcm-599-vs-placebo-in-preclinical-models-a-comparative-guide)

Disclaimer & Data Validity:

The information provided in this document is for Research Use Only (RUO) and is strictly not intended for diagnostic or therapeutic procedures. While BenchChem strives to provide accurate protocols, we make no warranties, express or implied, regarding the fitness of this product for every specific experimental setup.

Technical Support: The protocols provided are for reference purposes. Unsure if this reagent suits your experiment?

Need Industrial/Bulk Grade? [Request Custom Synthesis Quote](#)

BenchChem

Our mission is to be the trusted global source of essential and advanced chemicals, empowering scientists and researchers to drive progress in science and industry.

Contact

Address: 3281 E Guasti Rd
Ontario, CA 91761, United States
Phone: (601) 213-4426
Email: info@benchchem.com

[Contact our Ph.D. Support Team for a compatibility check](#)