

# Validating the Specificity of NR1H4 Activator 1: A Comparative Guide

**Author:** BenchChem Technical Support Team. **Date:** April 2026

## Compound of Interest

Compound Name: NR1H4 activator 1

Cat. No.: B13430107

[Get Quote](#)

For Researchers, Scientists, and Drug Development Professionals

This guide provides a comprehensive framework for validating the specificity of "NR1H4 activator 1," a potent and selective agonist for the Farnesoid X Receptor (FXR), also known as NR1H4.<sup>[1]</sup> Ensuring high specificity is paramount in drug development to minimize off-target effects and enhance therapeutic efficacy. This document outlines key experimental approaches, presents comparative data with other known FXR agonists, and provides detailed protocols to assess the binding and activation profile of NR1H4 activator 1.

## Introduction to NR1H4 (FXR) and the Importance of Activator Specificity

NR1H4, or the Farnesoid X Receptor (FXR), is a nuclear receptor primarily expressed in the liver, intestine, kidneys, and adrenal glands.<sup>[2][3][4]</sup> It functions as a key regulator of bile acid, lipid, and glucose homeostasis.<sup>[3][4]</sup> Upon activation by endogenous bile acids such as chenodeoxycholic acid (CDCA), FXR forms a heterodimer with the Retinoid X Receptor (RXR) and binds to specific DNA sequences known as Farnesoid X Receptor Response Elements (FXREs) in the promoter regions of target genes.<sup>[2][4][5][6]</sup> This interaction modulates the transcription of genes involved in various metabolic pathways.<sup>[7]</sup>

Given its central role in metabolic regulation, FXR has emerged as a promising therapeutic target for various conditions, including non-alcoholic steatohepatitis (NASH), primary biliary cholangitis (PBC), and other metabolic disorders. The development of synthetic FXR agonists, such as **NR1H4 activator 1**, offers the potential for more potent and targeted therapeutic interventions. However, the high degree of structural similarity among nuclear receptors presents a significant challenge in developing specific activators. Cross-reactivity with other nuclear receptors can lead to unintended biological effects and potential toxicities. Therefore, rigorous validation of activator specificity is a critical step in the preclinical development of any new FXR-targeted therapeutic.

## Comparative Analysis of NR1H4 Activators

To objectively assess the specificity of **NR1H4 activator 1**, its performance should be compared against well-characterized alternative FXR activators. This guide uses Chenodeoxycholic acid (CDCA), a natural FXR ligand, and GW4064, a potent synthetic FXR agonist, as points of comparison.

### Table 1: Comparative Binding Affinity (K<sub>i</sub>, nM) of NR1H4 Activators

This table summarizes the binding affinities of **NR1H4 activator 1** and comparator compounds for NR1H4 and a panel of representative off-target nuclear receptors. Lower K<sub>i</sub> values indicate higher binding affinity.

Compound	NR1H4 (FXR)	LXR $\alpha$ (NR1H3)	LXR $\beta$ (NR1H2)	PPAR $\alpha$ (NR1C1)	PPAR $\gamma$ (NR1C3)	RXR $\alpha$ (NR2B1)
NR1H4 activator 1	1.5	>10,000	>10,000	>10,000	>10,000	>10,000
GW4064	25	>10,000	>10,000	8,500	>10,000	>10,000
CDCA	10,000	>50,000	>50,000	>50,000	>50,000	>50,000

### Table 2: Comparative Potency (EC<sub>50</sub>, nM) in Reporter Gene Assay

This table presents the half-maximal effective concentration (EC50) of the activators in a cell-based reporter gene assay, indicating their functional potency for activating NR1H4 and the selected off-target receptors. Lower EC50 values signify greater potency.

Compound	NR1H4 (FXR)	LXR $\alpha$ (NR1H3)	LXR $\beta$ (NR1H2)	PPAR $\alpha$ (NR1C1)	PPAR $\gamma$ (NR1C3)	RXR $\alpha$ (NR2B1)
NR1H4 activator 1	1.0[1]	>10,000	>10,000	>10,000	>10,000	>10,000
GW4064	30	>10,000	>10,000	7,800	>10,000	>10,000
CDCA	17,000[3]	>50,000	>50,000	>50,000	>50,000	>50,000

## Signaling Pathways and Experimental Workflows

Visualizing the underlying biological processes and experimental procedures is crucial for understanding the validation strategy.

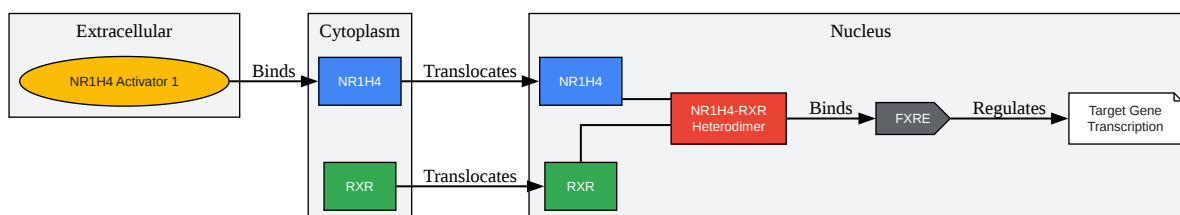

[Click to download full resolution via product page](#)

**Figure 1:** NR1H4 (FXR) Signaling Pathway.

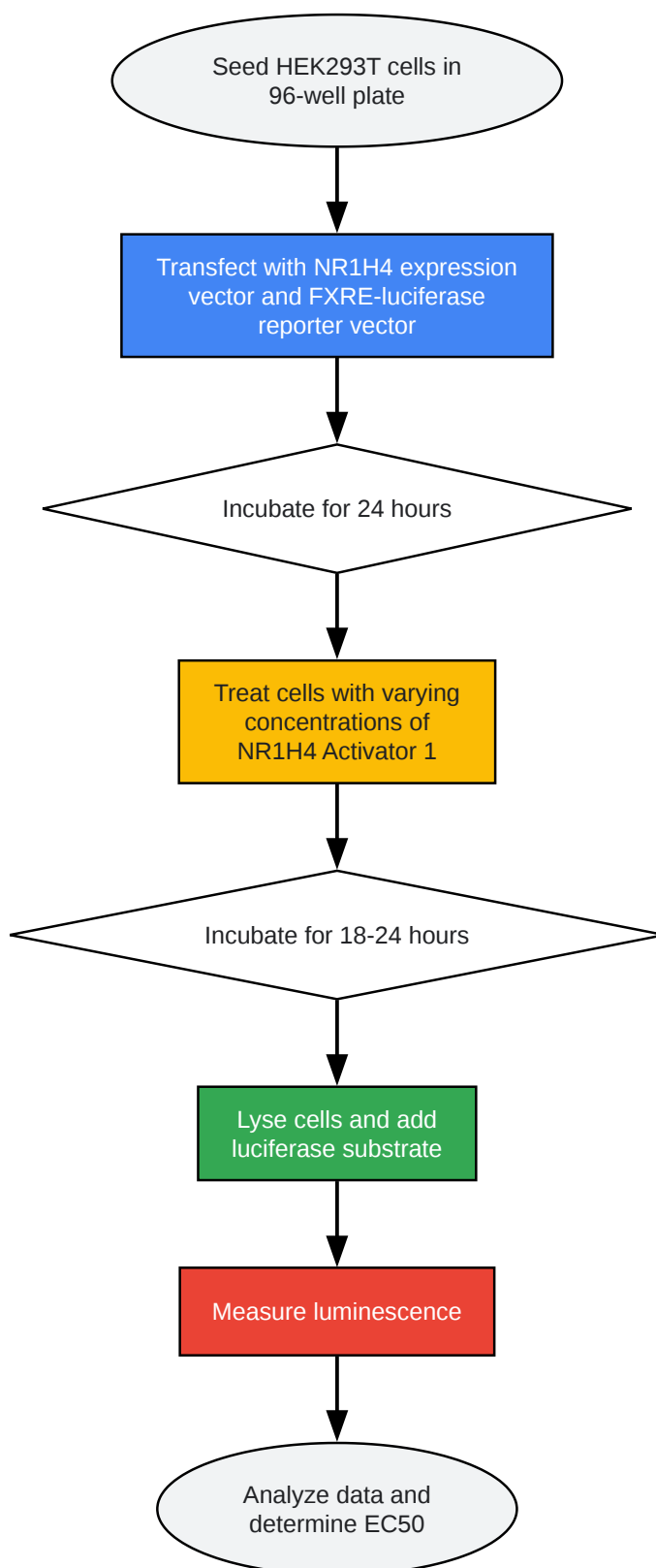

[Click to download full resolution via product page](#)

**Figure 2:** Reporter Gene Assay Workflow.

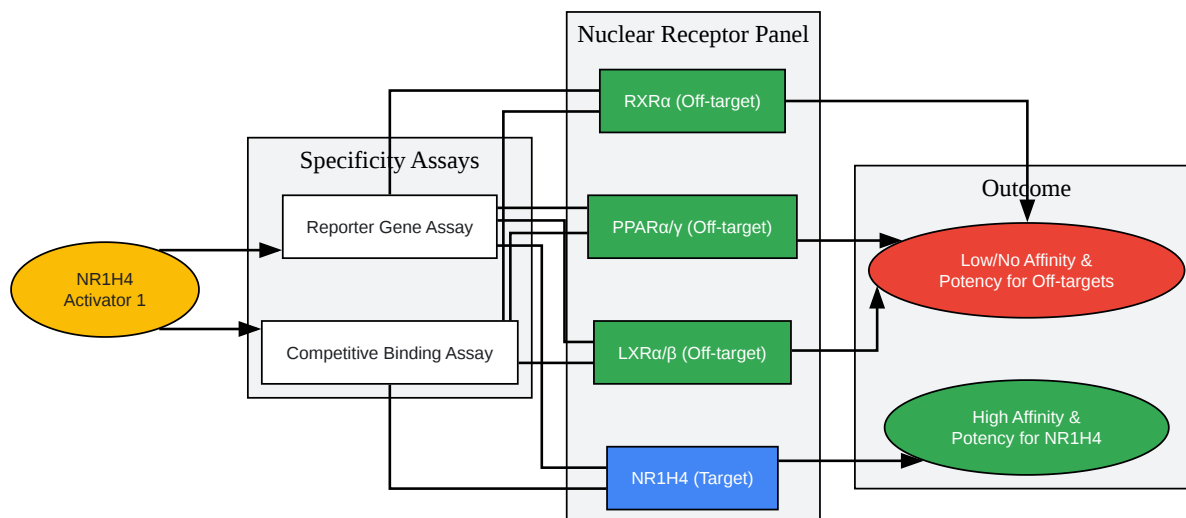

[Click to download full resolution via product page](#)

**Figure 3:** Logic of Specificity Screening.

## Experimental Protocols

Detailed and reproducible experimental protocols are essential for the accurate assessment of compound specificity.

### Competitive Radioligand Binding Assay

This assay determines the binding affinity ( $K_i$ ) of a test compound for a specific nuclear receptor by measuring its ability to displace a radiolabeled ligand.

Materials:

- Purified, recombinant human NR1H4, LXR $\alpha$ , LXR $\beta$ , PPAR $\alpha$ , PPAR $\gamma$ , and RXR $\alpha$  ligand-binding domains (LBDs).

- Radiolabeled ligands (e.g., [3H]-GW4064 for NR1H4).
- Scintillation proximity assay (SPA) beads.
- Assay buffer (specific to each receptor).
- 96- or 384-well microplates.
- Microplate scintillation counter.

#### Procedure:

- To each well of a microplate, add the purified nuclear receptor LBD.
- Add increasing concentrations of the test compound (**NR1H4 activator 1**, GW4064, or CDCA).
- Add a constant concentration of the corresponding radiolabeled ligand.
- Add SPA beads.
- Incubate the plate at room temperature for 1-4 hours to reach equilibrium.
- Measure the radioactivity in each well using a microplate scintillation counter.
- Data Analysis: The concentration of the test compound that displaces 50% of the radiolabeled ligand (IC50) is determined. The Ki value is then calculated using the Cheng-Prusoff equation:  $K_i = IC_{50} / (1 + [L]/K_d)$ , where [L] is the concentration of the radiolabeled ligand and Kd is its dissociation constant.

## Cell-Based Reporter Gene Assay

This assay measures the functional potency (EC50) of a compound to activate a specific nuclear receptor and induce the expression of a reporter gene.

#### Materials:

- HEK293T cells (or other suitable host cell line).

- Expression vectors for full-length human NR1H4, LXR $\alpha$ , LXR $\beta$ , PPAR $\alpha$ , PPAR $\gamma$ , and RXR $\alpha$ .
- Reporter vector containing a luciferase or SEAP gene under the control of a response element for the respective nuclear receptor (e.g., a BSEP promoter for NR1H4).[8]
- Transfection reagent.
- Cell culture medium and supplements.
- Lysis buffer and luciferase or SEAP substrate.
- Luminometer.

#### Procedure:

- Seed HEK293T cells in a 96-well plate.
- Co-transfect the cells with the appropriate nuclear receptor expression vector and the corresponding reporter vector.[8]
- After 24 hours, replace the medium with fresh medium containing serial dilutions of the test compound.
- Incubate the cells for an additional 18-24 hours.
- If using a luciferase reporter, lyse the cells and add the luciferase substrate. If using a SEAP reporter, collect the culture medium and add the SEAP substrate.[8]
- Measure the luminescence using a luminometer.
- Data Analysis: Plot the luminescence signal against the compound concentration and fit the data to a sigmoidal dose-response curve to determine the EC50 value.

## Whole-Transcriptome Analysis (RNA-seq)

RNA-sequencing provides a global view of the transcriptional changes induced by a compound, allowing for an unbiased assessment of off-target gene activation.

#### Experimental Design:

- Cell Line: A biologically relevant cell line expressing endogenous NR1H4 (e.g., HepG2 human hepatoma cells).
- Treatment Groups:
  - Vehicle control (e.g., DMSO).
  - **NR1H4 activator 1** (at a concentration corresponding to its EC90 to maximize on-target and potential off-target effects).
  - Positive control: a known FXR agonist (e.g., GW4064).
- Replicates: A minimum of three biological replicates for each treatment group is recommended for statistical power.
- Time Points: A time-course experiment (e.g., 6, 12, and 24 hours) can provide insights into the dynamics of gene regulation.

#### Procedure:

- Culture and treat the cells according to the experimental design.
- Isolate total RNA from each sample, ensuring high quality and integrity.
- Prepare RNA-seq libraries (e.g., using a poly-A selection method).
- Sequence the libraries on a next-generation sequencing platform.
- Data Analysis:
  - Perform quality control on the raw sequencing reads.
  - Align the reads to a reference genome.
  - Quantify gene expression levels.
  - Perform differential gene expression analysis to identify genes that are significantly up- or down-regulated by **NR1H4 activator 1** compared to the vehicle control.

- Compare the gene expression profile of **NR1H4 activator 1** with that of the positive control to identify both shared (on-target) and unique (potential off-target) gene signatures.
- Perform pathway analysis and gene ontology enrichment analysis to understand the biological functions of the regulated genes.

## Conclusion

The validation of activator specificity is a cornerstone of modern drug discovery. By employing a multi-faceted approach that includes direct binding assays, functional cell-based assays, and global transcriptome profiling, researchers can build a comprehensive and robust data package to support the continued development of promising therapeutic candidates like **NR1H4 activator 1**. The methodologies and comparative data presented in this guide offer a clear and objective framework for assessing the specificity of novel NR1H4 activators, ultimately contributing to the development of safer and more effective medicines for metabolic diseases.

### *Need Custom Synthesis?*

*BenchChem offers custom synthesis for rare earth carbides and specific isotopic labeling.*

*Email: [info@benchchem.com](mailto:info@benchchem.com) or [Request Quote Online](#).*

## References

- [1. medchemexpress.com \[medchemexpress.com\]](https://www.medchemexpress.com)
- [2. indigobiosciences.com \[indigobiosciences.com\]](https://www.indigobiosciences.com)
- [3. Regulation of FXR Transcriptional Activity in Health and Disease: Emerging Roles of FXR Cofactors and Post-Translational Modifications - PMC \[pmc.ncbi.nlm.nih.gov\]](#)
- [4. Farnesoid X receptor - Wikipedia \[en.wikipedia.org\]](https://en.wikipedia.org/wiki/Farnesoid_X_receptor)
- [5. Ligand binding and heterodimerization with retinoid X receptor  \$\alpha\$  \(RXR \$\alpha\$ \) induce farnesoid X receptor \(FXR\) conformational changes affecting coactivator binding - PMC \[pmc.ncbi.nlm.nih.gov\]](#)
- [6. Farnesoid X receptor \(FXR\): Structures and ligands - PMC \[pmc.ncbi.nlm.nih.gov\]](#)
- [7. atlasgeneticsoncology.org \[atlasgeneticsoncology.org\]](https://atlasgeneticsoncology.org)
- [8. caymanchem.com \[caymanchem.com\]](https://www.caymanchem.com)

- To cite this document: BenchChem. [Validating the Specificity of NR1H4 Activator 1: A Comparative Guide]. BenchChem, [2026]. [Online PDF]. Available at: [<https://www.benchchem.com/product/b13430107/docs#validating-the-specificity-of-nr1h4-activator-1-a-comparative-guide>]

---

### Disclaimer & Data Validity:

The information provided in this document is for Research Use Only (RUO) and is strictly not intended for diagnostic or therapeutic procedures. While BenchChem strives to provide accurate protocols, we make no warranties, express or implied, regarding the fitness of this product for every specific experimental setup.

**Technical Support:** The protocols provided are for reference purposes. Unsure if this reagent suits your experiment?

**Need Industrial/Bulk Grade?** [Request Custom Synthesis Quote](#)

## BenchChem

Our mission is to be the trusted global source of essential and advanced chemicals, empowering scientists and researchers to drive progress in science and industry.

### Contact

Address: 3281 E Guasti Rd  
Ontario, CA 91761, United States  
Phone: (601) 213-4426  
Email: [info@benchchem.com](mailto:info@benchchem.com)

[Contact our Ph.D. Support Team for a compatibility check](#)