

Technical Support Center: Azetidine Protecting Group Strategies

Author: BenchChem Technical Support Team. **Date:** May 2026

Compound of Interest

Compound Name: 3-(Azetidinomethyl)phenyl
cyclohexyl ketone

CAS No.: 898772-42-4

Cat. No.: B1343385

[Get Quote](#)

Current Status: Operational Ticket Focus: High-Strain Heterocycle Synthesis Assigned
Specialist: Senior Application Scientist

Executive Summary: The 26 kcal/mol Challenge

Azetidines possess a ring strain energy of approximately 26-27 kcal/mol. Unlike pyrrolidines (negligible strain) or piperidines, the azetidine ring is a loaded spring. The central challenge in azetidine chemistry is not just blocking the nitrogen, but doing so without triggering the release of this strain energy, which inevitably leads to ring opening (forming propanamines) or polymerization.

This guide moves beyond standard "Greene's Protective Groups" lists to focus on structural integrity strategies specific to the 4-membered ring.

Strategic Decision Matrix

Before selecting a reagent, determine your phase of synthesis. Azetidine protection is rarely "one size fits all."

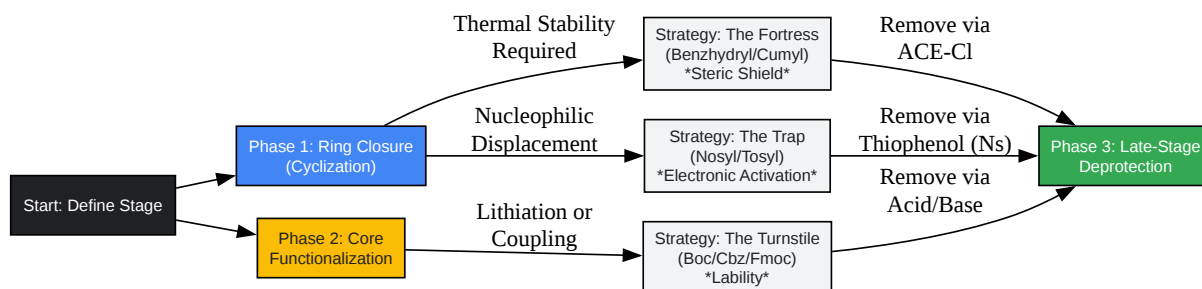

[Click to download full resolution via product page](#)

Figure 1: Decision matrix for selecting azetidine protecting groups based on synthetic stage.

Module 1: "The Fortress" – Benzhydryl (DPM) & Cumyl

Use Case: Constructing the azetidine ring. These bulky groups prevent over-alkylation and stabilize the ring against thermal opening during harsh cyclization conditions. The Problem: They are notoriously difficult to remove. Hydrogenation often fails due to steric bulk or catalyst poisoning by the amine.

Protocol: The ACE-Cl Deprotection (Standard of Care)

Do not use hydrogenation for bulky N-alkyl azetidines unless necessary. Use the Olofson method.

Reagents:

- 1-Chloroethyl chloroformate (ACE-Cl)
- 1,2-Dichloroethane (DCE) or Toluene (anhydrous)
- Methanol (MeOH)

Step-by-Step Workflow:

- Acylation: Dissolve N-benzhydryl azetidine (1.0 equiv) in dry DCE (0.2 M). Add ACE-Cl (1.2–1.5 equiv) at 0°C.
- Displacement: Reflux the mixture for 2–4 hours. Monitor by LCMS for the conversion of the starting material to the intermediate carbamate (usually stable).
 - Note: The benzhydryl chloride byproduct is non-volatile.
- Evaporation: Concentrate the reaction mixture to dryness to remove excess ACE-Cl.
- Methanolysis: Redissolve the crude carbamate residue in MeOH. Reflux for 1 hour. This decomposes the carbamate into the azetidine hydrochloride salt, CO₂, and acetaldehyde.
- Isolation: Concentrate to obtain the pure azetidine·HCl salt.^[1]

Why this works: The reaction proceeds via an intramolecular elimination mechanism that avoids generating strong nucleophiles that could open the ring.

Module 2: "The Trap" – Sulfonyls (Nosyl vs. Tosyl)

Use Case: Cyclization via nucleophilic displacement (e.g., displacing a mesylate). Critical

Warning: Avoid Tosyl (Ts) groups unless they are permanent. Removing a Tosyl group often requires reductive conditions (Na/Naphthalene or Mg/MeOH) that can cleave the strained C-N bond of the azetidine.

Protocol: Fukuyama Deprotection of N-Nosyl Azetidines

Always use o-Nosyl (2-nitrobenzenesulfonyl) instead of Tosyl for temporary protection.

Reagents:

- Thiophenol (PhSH) or Thioglycolic acid
- Cesium Carbonate (Cs₂CO₃) or DBU
- Acetonitrile (MeCN) or DMF

Step-by-Step Workflow:

- Setup: Dissolve N-Nosyl azetidine (1.0 equiv) in MeCN (0.1 M).
- Scavenger Addition: Add Cs₂CO₃ (3.0 equiv) followed by Thiophenol (1.2 equiv).
 - Safety: Thiophenol is toxic and malodorous. Use bleach in the trap.
- Reaction: Stir at room temperature (RT) for 1–3 hours. The solution typically turns bright yellow (Meisenheimer complex).
- Workup: Dilute with ether/water. The amine remains in the organic phase (or aqueous if acidic workup is used).

Why this works: The electron-withdrawing nitro group makes the sulfur susceptible to nucleophilic attack by the thiolate, releasing the amine under mild, non-reductive conditions that preserve the ring.

Module 3: "The Turnstile" – Carbamates (Boc/Cbz)

Use Case: Late-stage functionalization (e.g., C-H activation, peptide coupling).

Data: Stability & Ring Opening Risk^{[2][3]}

Protecting Group	Deprotection Reagent	Ring Opening Risk	Mitigation Strategy
Boc	TFA / HCl	High	Use Scavengers; Avoid nucleophilic solvents.
Cbz	H ₂ / Pd/C	Medium	Poison catalyst (add pyridine); Avoid high pressure.
Fmoc	Piperidine	Low	Standard protocols usually safe.
Botc	H ₃ PO ₄ / Heat	Very Low	Excellent for C-H lithiation (prevents elimination).

Troubleshooting Guide: Acidic Deprotection of N-Boc

Issue: Users report formation of ring-opened propanolamine adducts during TFA deprotection.

Root Cause: The protonated azetidine is an electrophile. If the counter-ion (e.g., Trifluoroacetate) or solvent acts as a nucleophile, it attacks the

-carbon, relieving ring strain.

Corrective Protocol:

- Solvent Switch: Do not use neat TFA. Use 4N HCl in Dioxane or TFA/DCM (1:4).
- Scavenger: Add Triethylsilane (TES) or 1,3-dimethoxybenzene (2–5 equiv) to the deprotection mix. This captures the tert-butyl cation immediately, preventing it from alkylating the ring or participating in side reactions.
- Temperature: Perform the reaction at 0°C, not Room Temperature.

Advanced Workflow: C-H Functionalization

For researchers attempting to functionalize the azetidine ring (e.g.,

-lithiation), standard Boc groups often lead to

-elimination.

Recommendation: Use the Botc (tert-butoxythiocarbonyl) group.^[2]

- Mechanism: The sulfur atom coordinates the lithium, stabilizing the carbanion and directing the electrophile, while preventing the ring-opening elimination common with carbonyls.

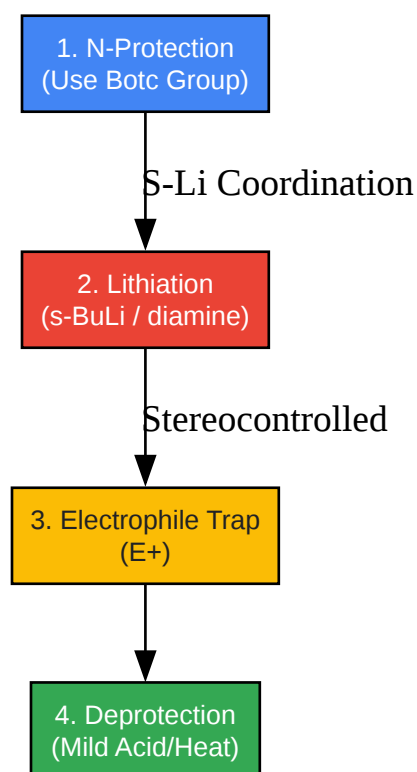

[Click to download full resolution via product page](#)

Figure 2: Workflow for C-H functionalization using the Botc directing group.

References

- Couty, F., & Evano, G. (2006). Azetidines: New Tools for the Synthesis of Nitrogen Heterocycles. *Organic Preparations and Procedures International*. [Link](#)
- Olofson, R. A., et al. (1984). A New Reagent for the Selective Dealkylation of Tertiary Amines (ACE-Cl). *Journal of Organic Chemistry*. [Link](#)
- Fukuyama, T., et al. (1995). 2- and 4-Nitrobenzenesulfonamides: Exceptionally Versatile Means for Preparation of Secondary Amines. *Tetrahedron Letters*.^[3] [Link](#)
- Hodgson, D. M., et al. (2014).^[3] Amine Protection/ α -Activation with the tert-Butoxythiocarbonyl Group: Application to Azetidine Lithiation–Electrophilic Substitution.^[2] *Organic Letters*.^[1] [Link](#)

- Padwa, A., et al. (2006). Strain-Release Chemistry of Azetidines.[4][5] Chemical Reviews.
[Link](#)

Need Custom Synthesis?

BenchChem offers custom synthesis for rare earth carbides and specific isotopic labeling.

Email: info@benchchem.com or [Request Quote Online](#).

Sources

- 1. A Facile Deprotection of Secondary Acetamides [[organic-chemistry.org](https://www.organic-chemistry.org)]
- 2. pubs.acs.org [pubs.acs.org]
- 3. [researchgate.net](https://www.researchgate.net) [[researchgate.net](https://www.researchgate.net)]
- 4. Intramolecular Ring-Opening Decomposition of Aryl Azetidines - PMC [[pmc.ncbi.nlm.nih.gov](https://pubmed.ncbi.nlm.nih.gov)]
- 5. BJOC - Ring opening of photogenerated azetidinols as a strategy for the synthesis of aminodioxolanes [[beilstein-journals.org](https://www.beilstein-journals.org)]
- To cite this document: BenchChem. [Technical Support Center: Azetidine Protecting Group Strategies]. BenchChem, [2026]. [Online PDF]. Available at: [<https://www.benchchem.com/product/b1343385/docs#technical-support-center-azetidine-protecting-group-strategies>]

Disclaimer & Data Validity:

The information provided in this document is for Research Use Only (RUO) and is strictly not intended for diagnostic or therapeutic procedures. While BenchChem strives to provide accurate protocols, we make no warranties, express or implied, regarding the fitness of this product for every specific experimental setup.

Technical Support: The protocols provided are for reference purposes. Unsure if this reagent suits your experiment?

Need Industrial/Bulk Grade? [Request Custom Synthesis Quote](#)

BenchChem

Our mission is to be the trusted global source of essential and advanced chemicals, empowering scientists and researchers to drive progress in science and industry.

Contact

Address: 3281 E Guasti Rd

Ontario, CA 91761, United States

Phone: (601) 213-4426

Email: info@benchchem.com

[Contact our Ph.D. Support Team for a compatibility check](#)