

# Spectroscopic analysis for the structural confirmation of 2'-Chloro-3-phenylpropiophenone

**Author:** BenchChem Technical Support Team. **Date:** April 2026

## Compound of Interest

Compound Name:	2'-Chloro-3-phenylpropiophenone
CAS No.:	898764-45-9
Cat. No.:	B1343419

[Get Quote](#)

## Spectroscopic Confirmation of 2'-Chloro-3-phenylpropiophenone: A Comparative Guide Part 1: Executive Summary & Core Directive

**Objective:** To establish a robust, self-validating spectroscopic protocol for the structural confirmation of **2'-Chloro-3-phenylpropiophenone** (IUPAC: 1-(2-chlorophenyl)-3-phenylpropan-1-one), distinguishing it from critical regioisomers (e.g., 4'-chloro analog) and synthetic impurities.

**The Challenge:** In the synthesis of dihydrochalcones (1,3-diphenylpropan-1-ones), Friedel-Crafts acylation or Grignard reactions often yield regioisomeric mixtures. The 2'-chloro isomer (ortho-substituted) presents unique spectroscopic challenges due to the steric inhibition of resonance (SIR) caused by the bulky chlorine atom adjacent to the carbonyl group. This guide moves beyond basic characterization, comparing the target molecule's spectral "performance" against its most likely contaminants to ensure pharmaceutical-grade identity.

## Part 2: Comparative Spectroscopic Strategy

To confirm the structure of **2'-Chloro-3-phenylpropiophenone**, we must triangulate data from NMR, IR, and MS. The "performance" of these techniques is evaluated based on their ability to resolve the ortho-chloro substitution pattern from the para-chloro alternative.

### Nuclear Magnetic Resonance (NMR) – The Gold Standard

NMR provides the definitive structural proof. The key differentiator is the splitting pattern of the benzoyl ring protons.

- Target (2'-Chloro): The ortho-substitution breaks the symmetry of the benzoyl ring. You will observe a complex ABCD-like multiplet system for the 4 aromatic protons on the chlorobenzoyl ring. The proton at the 6'-position (ortho to carbonyl) will be deshielded but slightly less so than in the para-isomer due to the twisting of the carbonyl group out of the ring plane.
- Alternative (4'-Chloro): Possesses a plane of symmetry, resulting in a classic AA'BB' (or AA'XX') doublet system. This is easily distinguishable from the asymmetric 2'-isomer.

### Infrared Spectroscopy (FT-IR) – The Ortho-Effect

The "performance" of IR here lies in detecting the Steric Inhibition of Resonance.

- Target (2'-Chloro): The bulky ortho-chlorine forces the carbonyl group out of coplanarity with the benzene ring. This reduces conjugation, increasing the double-bond character of the C=O bond.
  - Result: Blue shift (higher frequency) of the C=O stretch ( $\sim 1695\text{--}1705\text{ cm}^{-1}$ ).
- Alternative (4'-Chloro): The molecule remains planar, allowing full conjugation.
  - Result: Red shift (lower frequency) of the C=O stretch ( $\sim 1680\text{--}1685\text{ cm}^{-1}$ ).

### Mass Spectrometry (MS) – Fragmentation Logic

MS confirms the molecular weight and the propiophenone backbone but is less effective at distinguishing isomers than NMR.

- **Key Feature:** The presence of the Acylium ion ( $m/z$  139/141) confirms the 2-chlorobenzoyl fragment.
- **McLafferty Rearrangement:** The 3-phenylpropyl chain lacks a gamma-hydrogen (the gamma-position is the ipso-carbon of the phenyl ring). Thus, the classic McLafferty rearrangement is suppressed, distinguishing this scaffold from alkyl-chain analogs (e.g., valerophenone).

## Part 3: Experimental Protocols

### Protocol A: High-Resolution $^1\text{H}$ & $^{13}\text{C}$ NMR

Objective: Definitive assignment of regio-chemistry.

- **Sample Preparation:** Dissolve 10-15 mg of the compound in 0.6 mL of  $\text{CDCl}_3$  (Chloroform-d, 99.8% D) containing 0.03% TMS as an internal standard. Ensure the solution is free of suspended solids (filter if necessary).
- **Acquisition Parameters (400 MHz or higher):**
  - **Pulse Sequence:** Standard zg30.
  - **Temperature:** 298 K.
  - **Scans:** 16 ( $^1\text{H}$ ), 1024 ( $^{13}\text{C}$ ) to ensure  $S/N > 100:1$ .
  - **Spectral Width:** -2 to 14 ppm ( $^1\text{H}$ ).
- **Processing:** Apply exponential multiplication ( $\text{LB} = 0.3$  Hz) prior to Fourier Transform. Phase and baseline correct manually.

### Protocol B: FT-IR Analysis (ATR Method)

Objective: Confirmation of carbonyl environment.

- **Setup:** Use a Diamond ATR (Attenuated Total Reflectance) accessory.

- Blank: Collect a background spectrum of the clean crystal (air).
- Measurement: Place solid/oil sample on the crystal. Apply pressure clamp.
- Scan: 32 scans at 4  $\text{cm}^{-1}$  resolution.
- Analysis: Focus on the 1650–1750  $\text{cm}^{-1}$  region.

## Part 4: Data Presentation & Comparison

The following table contrasts the expected spectral data for the target compound versus its primary isomer (4'-Chloro).

Table 1: Comparative Spectral Data

Feature	Target: 2'-Chloro-3-phenylpropiofenone	Alternative: 4'-Chloro-3-phenylpropiofenone	Differentiation Logic
1H NMR (Benzoyl Ring)	Multiplet (4H), 7.2–7.5 ppm. Asymmetric pattern (ABCD). H-6' is distinct.	Two Doublets (4H), ~7.9 (d) & ~7.4 (d) ppm. Symmetric AA'BB' system.	Symmetry: 2'-Cl is asymmetric; 4'-Cl is symmetric.
1H NMR (Alkyl Chain)	Triplet (~3.2 ppm, 2H) & Triplet (~3.0 ppm, 2H).	Triplet (~3.2 ppm, 2H) & Triplet (~3.0 ppm, 2H).	Minimal difference; confirms backbone only.
13C NMR (C=O)	~200–202 ppm. Slightly shielded due to twist.	~197–199 ppm. Deshielded due to planarity/conjugation.	Shift: Ortho-twist effects.
FT-IR (C=O Stretch)	~1695–1705 $\text{cm}^{-1}$ (Higher freq).	~1680–1685 $\text{cm}^{-1}$ (Lower freq).	Conjugation: 2'-Cl has reduced conjugation (SIR effect).
MS (Base Peak)	m/z 139/141 (2-chlorobenzoyl cation).	m/z 139/141 (4-chlorobenzoyl cation).	Indistinguishable by m/z alone; requires fingerprinting.

## Part 5: Visualization of Analytical Logic

### Diagram 1: Structural Confirmation Workflow

This decision tree guides the analyst through the confirmation process, prioritizing the most discriminatory techniques.

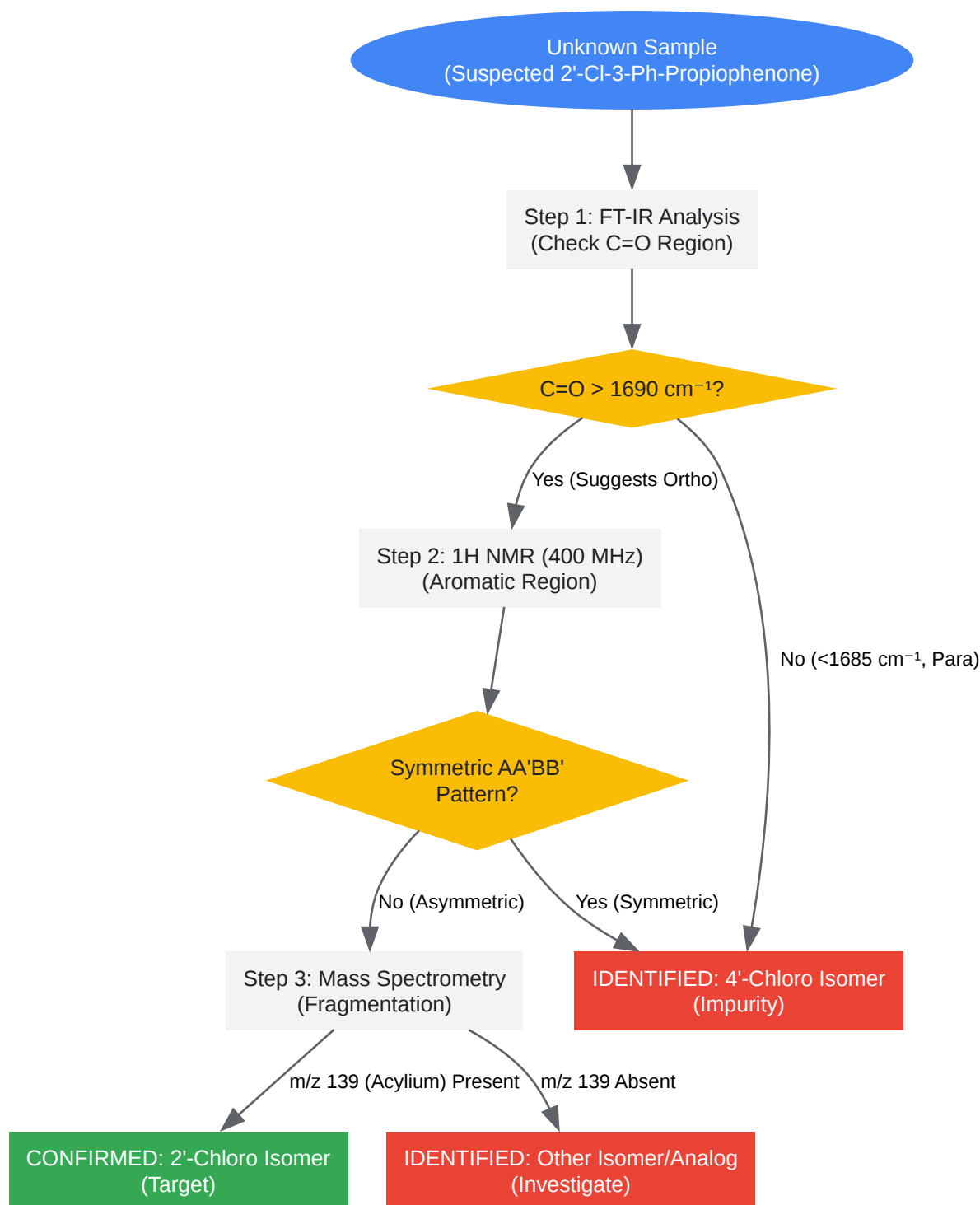

[Click to download full resolution via product page](#)

Caption: Analytical decision tree for distinguishing **2'-Chloro-3-phenylpropiophenone** from its para-isomer.

## Diagram 2: Mass Spectrometry Fragmentation Logic

Understanding the fragmentation helps rule out alkyl-chain variants (e.g., alpha-chloro derivatives).

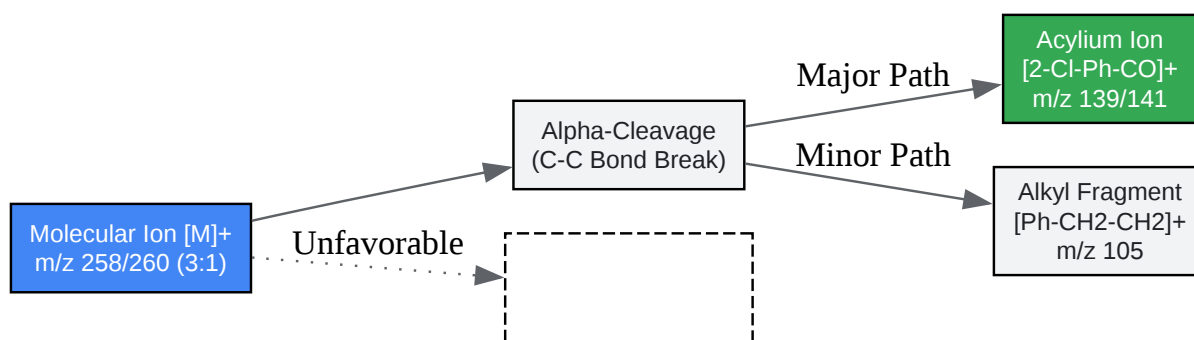

[Click to download full resolution via product page](#)

Caption: Fragmentation pathway highlighting the dominant acylium ion formation and lack of McLafferty rearrangement.

## References

- National Institute of Standards and Technology (NIST). Acetophenone, 2-chloro- (Ortho-Chloroacetophenone) Infrared Spectrum. NIST Chemistry WebBook, SRD 69. [\[Link\]](#)
- Royal Society of Chemistry. Mass spectrometry-based identification of ortho-, meta- and para-isomers using infrared ion spectroscopy. Analyst, 2020. [\[Link\]](#)
- SpectraBase. 1-(2-Chlorophenyl)-3-phenylpropan-1-one Spectral Data. Wiley Science Solutions. [\[Link\]](#)
- Silverstein, R. M., Webster, F. X., & Kiemle, D. J. Spectrometric Identification of Organic Compounds.

- To cite this document: BenchChem. [Spectroscopic analysis for the structural confirmation of 2'-Chloro-3-phenylpropiophenone]. BenchChem, [2026]. [Online PDF]. Available at: [<https://www.benchchem.com/product/b1343419/docs#spectroscopic-analysis-for-the-structural-confirmation-of-2-chloro-3-phenylpropiophenone>]

---

### Disclaimer & Data Validity:

The information provided in this document is for Research Use Only (RUO) and is strictly not intended for diagnostic or therapeutic procedures. While BenchChem strives to provide accurate protocols, we make no warranties, express or implied, regarding the fitness of this product for every specific experimental setup.

**Technical Support:** The protocols provided are for reference purposes. Unsure if this reagent suits your experiment?

**Need Industrial/Bulk Grade?** [Request Custom Synthesis Quote](#)

## BenchChem

Our mission is to be the trusted global source of essential and advanced chemicals, empowering scientists and researchers to drive progress in science and industry.

### Contact

Address: 3281 E Guasti Rd  
Ontario, CA 91761, United States  
Phone: (601) 213-4426  
Email: [info@benchchem.com](mailto:info@benchchem.com)

[Contact our Ph.D. Support Team for a compatibility check](#)