

The Genesis and Evolution of Pyrazole-4-Carbonitrile Compounds: A Technical Guide

Author: BenchChem Technical Support Team. **Date:** May 2026

Compound of Interest

Compound Name: *1-ethyl-1H-pyrazole-4-carbonitrile*

CAS No.: *1006434-01-0*

Cat. No.: *B1342748*

[Get Quote](#)

For Researchers, Scientists, and Drug Development Professionals

Abstract

The pyrazole-4-carbonitrile core is a privileged scaffold in medicinal chemistry, forming the backbone of numerous biologically active compounds. This technical guide provides an in-depth exploration of the discovery, history, and synthetic evolution of this important class of molecules. We delve into seminal synthetic methodologies, from the foundational Knorr pyrazole synthesis to modern, efficient multicomponent reactions. Detailed experimental protocols for key syntheses are provided, alongside a comprehensive summary of the biological activities of notable pyrazole-4-carbonitrile derivatives. Furthermore, we visualize key signaling pathways modulated by these compounds, offering insights into their mechanisms of action and therapeutic potential.

A Historical Perspective: From Pyrazoles to a Key Pharmacophore

The journey of pyrazole chemistry began in 1883 with Ludwig Knorr's discovery of pyrazole itself, synthesized through the condensation of ethyl acetoacetate and phenylhydrazine. This seminal work, known as the Knorr pyrazole synthesis, laid the groundwork for the exploration of this versatile heterocyclic system. While the initial focus was on the broader class of pyrazoles, the unique electronic properties conferred by the nitrile group at the 4-position gradually emerged as a key feature for potent and selective biological activity.

The first synthesis of a pyrazole-4-carbonitrile derivative can be traced back to the mid-20th century, with subsequent decades witnessing a rapid expansion of synthetic methodologies. The development of multicomponent reactions in the late 20th and early 21st centuries marked a significant turning point, enabling the rapid and efficient generation of diverse libraries of pyrazole-4-carbonitrile analogs for high-throughput screening and drug discovery programs.

Synthetic Methodologies: A Journey of Innovation

The synthesis of pyrazole-4-carbonitrile compounds has evolved significantly, driven by the need for efficiency, diversity, and sustainability.

The Classical Approach: Knorr Pyrazole Synthesis

The Knorr synthesis remains a fundamental method for constructing the pyrazole ring. It involves the condensation of a β -dicarbonyl compound (or a functional equivalent) with a hydrazine derivative. For the synthesis of pyrazole-4-carbonitriles, a key precursor is a β -ketonitrile or a related species.

Experimental Protocol: Knorr-type Synthesis of a Pyrazolone

- Reactants: Ethyl benzoylacetate (3 mmol) and hydrazine hydrate (6 mmol).
- Solvent and Catalyst: 1-Propanol (3 mL) and 3 drops of glacial acetic acid.
- Procedure:
 - Combine ethyl benzoylacetate and hydrazine hydrate in a 20-mL scintillation vial.
 - Add 1-propanol and glacial acetic acid.
 - Heat the reaction mixture on a hot plate with stirring at approximately 100°C for 1 hour.

- Monitor the reaction progress using thin-layer chromatography (TLC) with a mobile phase of 30% ethyl acetate/70% hexane.
- Once the ketoester is consumed, add water (10 mL) to the hot reaction mixture with stirring to induce precipitation.
- Cool the mixture in an ice bath to facilitate further precipitation.
- Collect the solid product by filtration using a Buchner funnel.
- Wash the collected solid with a small amount of cold water and allow it to air dry.^[1]

Modern Era: Multicomponent Reactions (MCRs)

Multicomponent reactions have revolutionized the synthesis of pyrazole-4-carbonitriles by allowing the one-pot assembly of multiple starting materials. These reactions are highly atom-economical and offer a straightforward route to complex molecules. A common MCR for pyrazole-4-carbonitriles involves the condensation of an aldehyde, malononitrile, and a hydrazine.

Experimental Protocol: One-Pot, Three-Component Synthesis of 5-Amino-1,3-diaryl-1H-pyrazole-4-carbonitriles

- Reactants: Aromatic aldehyde (1 mmol), malononitrile (1 mmol), and phenylhydrazine (1 mmol).
- Catalyst: A dual-functional catalyst (specifics may vary based on the chosen literature method).
- Solvent: Often performed in a green solvent like ethanol or even under solvent-free conditions.
- Procedure:
 - In a round-bottomed flask, combine the aromatic aldehyde, malononitrile, and phenylhydrazine.
 - Add the catalyst.

- Heat the reaction mixture at 80°C for approximately 5 minutes.
- Monitor the reaction by TLC.
- Upon completion, the product often precipitates from the reaction mixture and can be isolated by filtration.
- The crude product can be further purified by recrystallization from ethanol.[2]

Green Chemistry Approaches

In recent years, there has been a significant shift towards developing more environmentally friendly synthetic methods. For pyrazole-4-carbonitriles, this has included the use of water as a solvent, microwave-assisted synthesis to reduce reaction times, and the use of reusable catalysts.[3]

Biological Significance and Therapeutic Applications

The pyrazole-4-carbonitrile scaffold is a cornerstone in the development of a wide range of therapeutic agents, primarily due to its ability to act as a potent and selective inhibitor of various enzymes, particularly kinases.

Kinase Inhibition

Kinases play a crucial role in cell signaling, and their dysregulation is a hallmark of many diseases, including cancer and inflammatory disorders. The pyrazole-4-carbonitrile moiety has proven to be an excellent pharmacophore for designing kinase inhibitors.

Table 1: Biological Activity of Selected Pyrazole-4-Carbonitrile Kinase Inhibitors

Compound/Drug Name	Target Kinase(s)	IC50/Ki Value	Disease Area	Reference
Ibrutinib	Bruton's tyrosine kinase (BTK)	IC50 = 0.5 nM	B-cell malignancies	[4]
Ruxolitinib	Janus kinase 1/2 (JAK1/2)	IC50 = 3.3 nM (JAK1), 2.8 nM (JAK2)	Myelofibrosis, Polycythemia vera	[5]
Compound 3f	JAK1, JAK2, JAK3	IC50 = 3.4 nM, 2.2 nM, 3.5 nM	Cancer	[5]
BIRB 796	p38 MAP kinase	Ki = 0.1 nM	Inflammatory diseases	[6]
Afuresertib (GSK2110183)	Akt1	Ki = 0.08 nM	Cancer	[7]
Compound 6	Aurora A kinase	IC50 = 0.16 μ M	Cancer	[7]
Compound 22	CDK2, CDK5	IC50 = 24 nM, 23 nM	Cancer	[7]

Other Biological Activities

Beyond kinase inhibition, pyrazole-4-carbonitrile derivatives have demonstrated a broad spectrum of pharmacological activities, including antimicrobial, anti-inflammatory, and neuroprotective effects.

Table 2: Diverse Biological Activities of Pyrazole-4-Carbonitrile Derivatives

Compound Class	Biological Activity	Quantitative Data	Reference
5-amido-1-(2,4-dinitrophenyl)-1H-pyrazole-4-carbonitriles	Antibacterial (MRSA)	MIC = 25.1 μ M	[4]
Pyrazole imines	Antioxidant	IC50 values reported	[1]
4-(Pyrazol-3-yl)-pyridines	JNK3 Inhibition	IC50 = 160 nM (for compound 12)	[8]

Signaling Pathways and Mechanisms of Action

Understanding the signaling pathways modulated by pyrazole-4-carbonitrile compounds is crucial for rational drug design and development.

Bruton's Tyrosine Kinase (BTK) Signaling Pathway

Ibrutinib, a landmark drug for B-cell cancers, is a potent and irreversible inhibitor of Bruton's tyrosine kinase (BTK). BTK is a critical component of the B-cell receptor (BCR) signaling pathway, which is essential for B-cell proliferation, survival, and differentiation. By inhibiting BTK, Ibrutinib effectively blocks these downstream signals, leading to apoptosis of malignant B-cells.

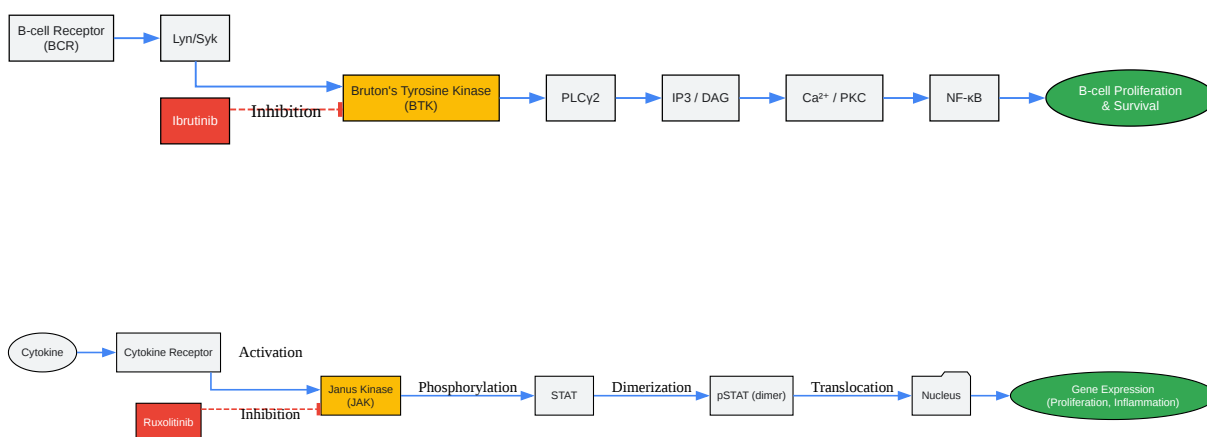

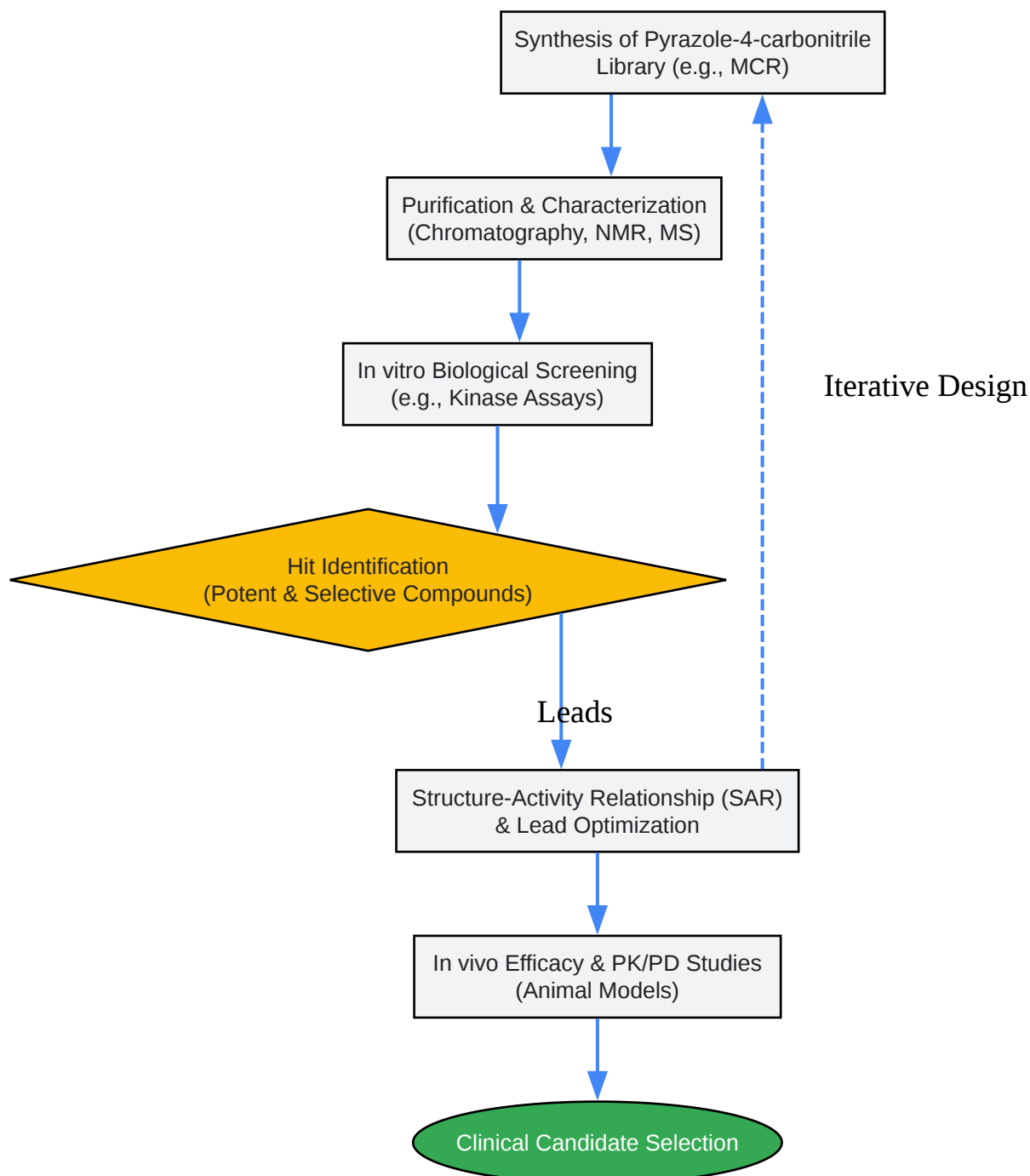
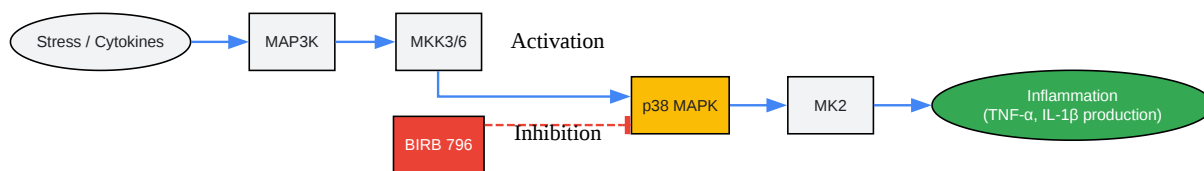

[Click to download full resolution via product page](#)

Need Custom Synthesis?

BenchChem offers custom synthesis for rare earth carbides and specific isotopic labeling.

Email: info@benchchem.com or [Request Quote Online](#).

References

- [1. researchgate.net \[researchgate.net\]](#)
- [2. researchgate.net \[researchgate.net\]](#)
- [3. biointerfaceresearch.com \[biointerfaceresearch.com\]](#)
- [4. Pyrazole synthesis \[organic-chemistry.org\]](#)
- [5. Design, Synthesis, and Antitumor Evaluation of 4-Amino-\(1H\)-pyrazole Derivatives as JAKs Inhibitors - PMC \[pmc.ncbi.nlm.nih.gov\]](#)
- [6. Pyrazole urea-based inhibitors of p38 MAP kinase: from lead compound to clinical candidate - PubMed \[pubmed.ncbi.nlm.nih.gov\]](#)
- [7. Evaluation of Substituted Pyrazole-Based Kinase Inhibitors in One Decade \(2011–2020\): Current Status and Future Prospects - PMC \[pmc.ncbi.nlm.nih.gov\]](#)
- [8. Synthesis and SAR of 4-\(pyrazol-3-yl\)-pyridines as novel c-Jun N-terminal kinase inhibitors - PMC \[pmc.ncbi.nlm.nih.gov\]](#)
- To cite this document: BenchChem. [The Genesis and Evolution of Pyrazole-4-Carbonitrile Compounds: A Technical Guide]. BenchChem, [2026]. [Online PDF]. Available at: [\[https://www.benchchem.com/product/b1342748/docs#the-genesis-and-evolution-of-pyrazole-4-carbonitrile-compounds-a-technical-guide\]](https://www.benchchem.com/product/b1342748/docs#the-genesis-and-evolution-of-pyrazole-4-carbonitrile-compounds-a-technical-guide)

Disclaimer & Data Validity:

The information provided in this document is for Research Use Only (RUO) and is strictly not intended for diagnostic or therapeutic procedures. While BenchChem strives to provide accurate protocols, we make no warranties, express or implied, regarding the fitness of this product for every specific experimental setup.

Technical Support: The protocols provided are for reference purposes. Unsure if this reagent suits your experiment?

Need Industrial/Bulk Grade? [Request Custom Synthesis Quote](#)

BenchChem

Our mission is to be the trusted global source of essential and advanced chemicals, empowering scientists and researchers to drive progress in science and industry.

Contact

Address: 3281 E Guasti Rd
Ontario, CA 91761, United States
Phone: (601) 213-4426
Email: info@benchchem.com

[Contact our Ph.D. Support Team for a compatibility check](#)