

Application Note: Optimized Synthesis of Propylthio-Based Organophosphates using 1-Propanethiol-SD

Author: BenchChem Technical Support Team. **Date:** May 2026

Compound of Interest

Compound Name: 1-Propanethiol-SD

Cat. No.: B13418756

[Get Quote](#)

Executive Summary

This application note details the protocol for utilizing **1-Propanethiol-SD** (High-Purity Anhydrous Grade) in the synthesis of organophosphorus pesticides, specifically focusing on Prothiofos (O-2,4-dichlorophenyl O-ethyl S-propyl phosphorodithioate) as a model system.

The "SD" designation in this context refers to "Synthesis-Dry" (< 50 ppm H₂O). The presence of moisture during the nucleophilic substitution of phosphorus halides by thiols is a critical failure mode, leading to the formation of acidic pyrophosphate impurities and reducing yield. This guide provides a self-validating method for handling this volatile nucleophile, ensuring high conversion rates and reproducible impurity profiles.

Chemical Context & Mechanism[1][2][3][4]

The Role of the Propylthio Moiety

In organophosphorus (OP) design, the S-propyl group serves two functions:

- Lipophilicity: It enhances the partition coefficient (LogP), facilitating penetration through the insect cuticle.
- Metabolic Activation: The thioether linkage is susceptible to oxidative desulfuration (bioactivation) within the pest, converting the pro-insecticide into its active oxon form.

The "SD" Criticality (Moisture Control)

Standard commercial 1-propanethiol often contains 0.5–1.0% water. In phosphorylation reactions, water competes with the thiol nucleophile (

):

- Desired Path:
- Parasitic Path (Hydrolysis):

The

species acts as an acid catalyst for the decomposition of the final product. Therefore, using **1-Propanethiol-SD** is not optional but required for stability.

Reaction Pathway (Prothiofos Model)

The synthesis involves the nucleophilic attack of the propylthiolate anion on O-ethyl O-(2,4-dichlorophenyl) phosphonochloridothioate.

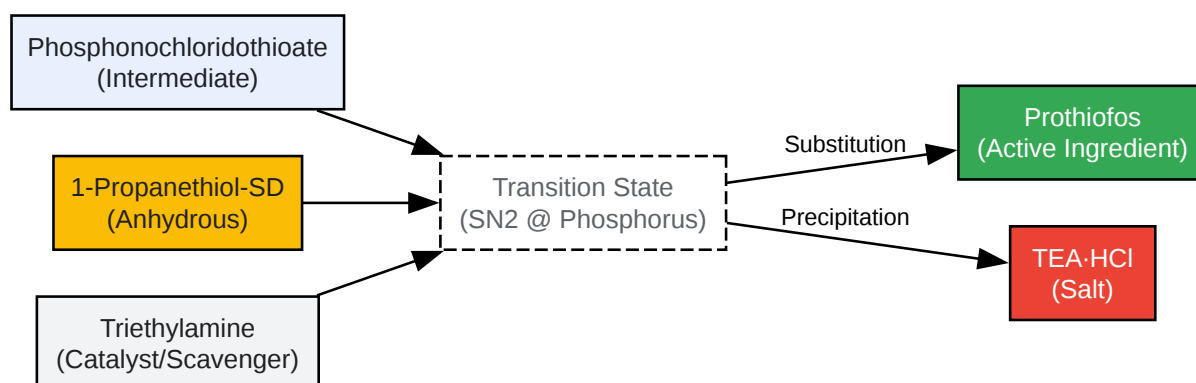

[Click to download full resolution via product page](#)

Figure 1: Nucleophilic substitution pathway for Prothiofos synthesis. High contrast nodes denote critical reagents.

Experimental Protocol

Materials & Equipment

- Reagent: **1-Propanethiol-SD** ($\geq 99.5\%$, $\text{H}_2\text{O} < 50$ ppm). Note: If SD grade is unavailable, dry standard reagent over activated 4Å molecular sieves for 24h.
- Substrate: O-ethyl O-(2,4-dichlorophenyl) phosphonochloridothioate.
- Solvent: Toluene (Anhydrous).
- Base: Triethylamine (TEA) or Pyridine (Dried over KOH).
- Equipment: 3-neck flask, mechanical stirrer, dropping funnel with pressure equalization, N_2 line, bleach scrubber (for odor control).

Safety: The Thiol Management System

1-Propanethiol has an extremely low odor threshold (0.00005 ppm) and is a CNS depressant.

- Containment: All transfers must occur under positive N_2 pressure.
- Scrubbing: Vent lines must pass through a 10% Sodium Hypochlorite (Bleach) solution to oxidize escaping thiols into odorless sulfonates.

Step-by-Step Synthesis Procedure

Step 1: Inert System Setup

- Flame-dry the 3-neck flask and assemble under a continuous Nitrogen stream.
- Charge the flask with 0.1 mol of the Phosphonochloridothioate intermediate dissolved in 100 mL anhydrous Toluene.
- Cool the system to 0–5°C using an ice/salt bath. Causality: Low temperature prevents thiothiono rearrangement.

Step 2: Reagent Preparation

- In a separate Schlenk flask, mix 0.105 mol (10.0 mL) of **1-Propanethiol-SD** with 0.11 mol of Triethylamine.
- Transfer this mixture to the dropping funnel under N₂.

Step 3: Controlled Addition

- Add the Thiol/Base mixture dropwise over 45 minutes.
- Critical Parameter: Maintain internal temperature < 10°C.
 - Observation: A white precipitate (TEA·HCl) will form immediately, confirming the reaction progress.

Step 4: Reaction Completion

- After addition, allow the mixture to warm to room temperature (25°C).
- Stir for 3 hours.
- Self-Validation Check (TLC/GC): Sample 50 µL. Dilute in EtOAc.
 - Success Criteria: Disappearance of Chloridothioate peak.
 - Failure Mode: If precursor remains, add 5% excess Thiol-SD and stir for 1h.

Step 5: Work-up

- Filter off the TEA·HCl salt.[\[1\]](#)
- Wash the filtrate with:
 - 1x 50 mL 5% HCl (removes residual amine).
 - 1x 50 mL 5% NaHCO₃ (neutralizes acid).
 - 2x 50 mL Brine.

- Dry organic layer over MgSO₄.
- Concentrate under reduced pressure (Rotavap) at 40°C.

Process Control & Data Analysis

Impurity Profiling

The "SD" grade primarily mitigates the formation of Impurity B (Hydrolysis).

Impurity Type	Structure / Origin	Cause of Formation	Mitigation Strategy
Impurity A	Dipropyl Disulfide	Oxidation of Thiol	Inadequate N ₂ purging; Old reagent.
Impurity B	O-ethyl O-(2,4-dichlorophenyl) phosphate	Hydrolysis (Moisture)	Use of 1-Propanethiol-SD; Wet solvent.
Impurity C	S,S-dipropyl phosphorodithioate	Double substitution	Excess thiol; Temperature > 20°C during addition.

Workflow Diagram

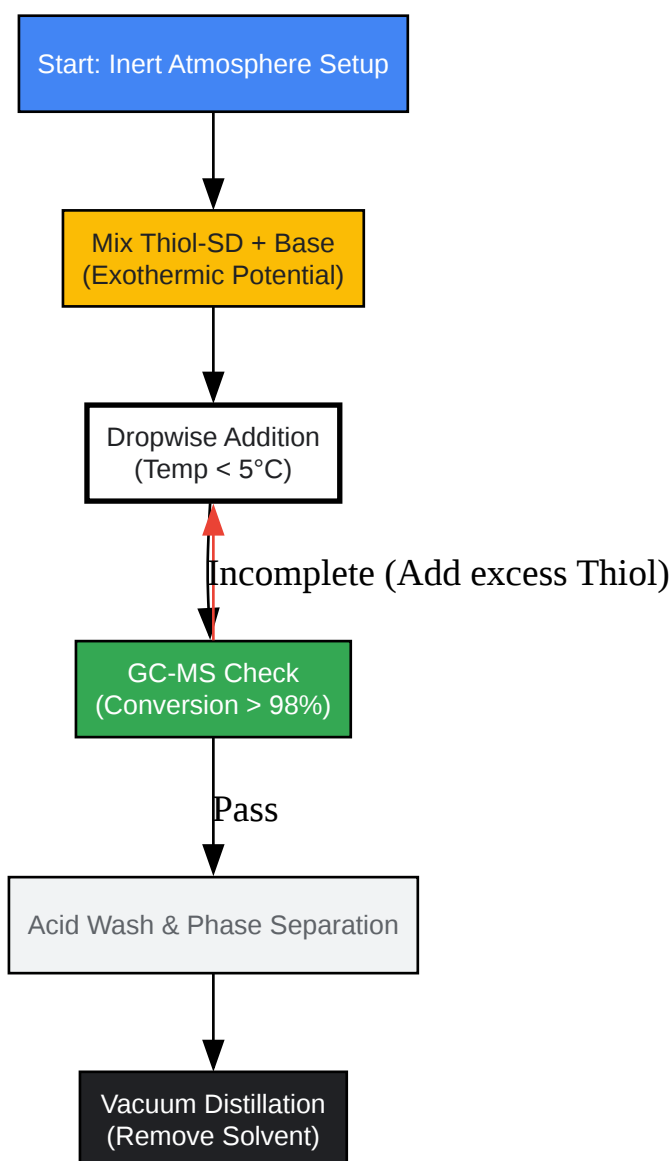

[Click to download full resolution via product page](#)

Figure 2: Operational workflow for the synthesis, emphasizing the decision loop at the monitoring stage.

Troubleshooting & Optimization

- Issue: Low Yield (< 80%).
 - Diagnosis: Volatility of 1-propanethiol resulted in loss before reaction.

- Fix: Use a jacketed dropping funnel cooled to 0°C or use a slight excess (1.1 eq) of the thiol.
- Issue: Product smells strongly of garlic/cabbage after workup.
 - Diagnosis: Residual unreacted thiol.
 - Fix: The final organic layer must be washed with a dilute Sodium Hypochlorite solution (0.5%) briefly to oxidize residual thiol, followed immediately by a thiosulfate wash to quench the oxidant.

References

- Preparation of O-ethyl S-n-propyl O-(2,4-dichlorophenyl) phosphorodithioate (Prothiofos).US Patent 4,064,203. (1977). Describes the fundamental condensation of phosphonochloridothioates with propyl mercaptan.
- Reactivity of Phosphorous Oxychloride and Thio-analogs.Common Organic Chemistry. (2023). Mechanisms of nucleophilic substitution on phosphorous centers.
- Safety Data Sheet: 1-Propanethiol.PubChem, National Library of Medicine. (Updated 2024). [\[2\]](#) Toxicity and handling data for propyl mercaptan.
- Metabolic Fate of Prothiofos.Journal of Environmental Science and Health. (2015). Discusses the bioactivation of the S-propyl moiety synthesized via this protocol.

Need Custom Synthesis?

BenchChem offers custom synthesis for rare earth carbides and specific isotopic labeling.

Email: info@benchchem.com or [Request Quote Online](#).

Sources

- [1. 1-Propanethiol | 107-03-9 \[chemicalbook.com\]](#)
- [2. Propyl mercaptan | C3H8S | CID 7848 - PubChem \[pubchem.ncbi.nlm.nih.gov\]](#)

- To cite this document: BenchChem. [Application Note: Optimized Synthesis of Propylthio-Based Organophosphates using 1-Propanethiol-SD]. BenchChem, [2026]. [Online PDF]. Available at: [<https://www.benchchem.com/product/b13418756/docs#application-note-optimized-synthesis-of-propylthio-based-organophosphates-using-1-propanethiol-sd>]

Disclaimer & Data Validity:

The information provided in this document is for Research Use Only (RUO) and is strictly not intended for diagnostic or therapeutic procedures. While BenchChem strives to provide accurate protocols, we make no warranties, express or implied, regarding the fitness of this product for every specific experimental setup.

Technical Support: The protocols provided are for reference purposes. Unsure if this reagent suits your experiment?

Need Industrial/Bulk Grade? [Request Custom Synthesis Quote](#)

BenchChem

Our mission is to be the trusted global source of essential and advanced chemicals, empowering scientists and researchers to drive progress in science and industry.

Contact

Address: 3281 E Guasti Rd
Ontario, CA 91761, United States
Phone: (601) 213-4426
Email: info@benchchem.com

[Contact our Ph.D. Support Team for a compatibility check](#)