

# Mass Spectrometry Fragmentation of PMP Acetals: A Comparative Guide

**Author:** BenchChem Technical Support Team. **Date:** May 2026

## Compound of Interest

Compound Name: 2-(4-Methoxyphenyl)-1,3-dioxane

CAS No.: 5689-71-4

Cat. No.: B13415501

[Get Quote](#)

Scope Note: This guide focuses on

-methoxyphenyl (or

-methoxybenzylidene) acetals used as protecting groups. It does not cover 1-phenyl-3-methyl-5-pyrazolone (PMP) derivatives used for carbohydrate labeling, which are chemically distinct animals.

## Executive Summary

In drug discovery and complex natural product synthesis, the

-methoxyphenyl (PMP) acetal serves a dual purpose: it is a robust protecting group for diols and a sensitive spectroscopic handle. While Nuclear Magnetic Resonance (NMR) is the gold standard for stereochemical assignment (e.g., Rychnovsky analysis), Mass Spectrometry (MS) provides the most rapid confirmation of structural integrity and regiochemistry.

The defining feature of PMP acetal fragmentation is the generation of the resonance-stabilized

-methoxybenzyl cation (

121). This guide analyzes the mechanistic origins of this diagnostic ion, compares it with alternative protecting groups, and provides validated protocols for its detection.

## Mechanistic Deep Dive: The Physics of Fragmentation

The fragmentation of PMP acetals under Electrospray Ionization (ESI) or Electron Impact (EI) is driven by the thermodynamic stability of the

-methoxybenzyl cation. Unlike simple alkyl acetals (like acetonides), the aromatic ring of the PMP group acts as a "charge sink."

### The Fragmentation Pathway[1][2]

- Ionization: The molecular ion (ESI) or (EI) is formed.
- C-O Bond Cleavage: The ether oxygen lone pair assists in cleaving the benzylic C-O bond.
- Formation of Diagnostic Ion (121): The -methoxybenzyl group cleaves to form a highly stable cation. The electron-donating methoxy group ( ) at the para position stabilizes the positive charge via resonance, making this ion significantly more abundant than the tropylium ion (91) seen in unsubstituted benzylidene acetals.
- Oxocarbenium Formation: Alternatively, the loss of the aryl radical (in EI) or neutral aryl aldehyde (in ESI/CID) generates a cyclic oxocarbenium ion on the diol backbone, which is useful for sequencing the polyol chain.

### Visualization of Signaling Pathway

The following diagram illustrates the competitive fragmentation pathways leading to the diagnostic

121 ion versus the diol-backbone oxocarbenium ion.

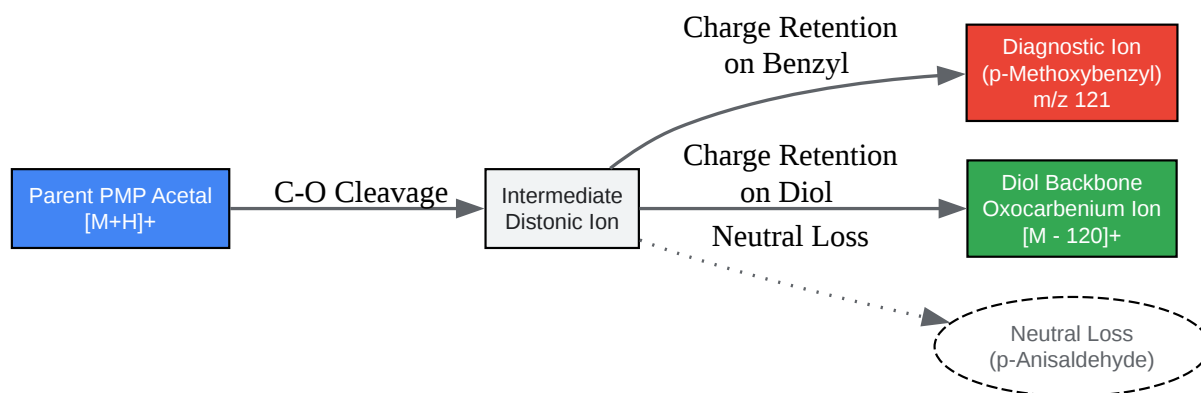

[Click to download full resolution via product page](#)

Figure 1: Competitive fragmentation pathways of protonated PMP acetals. The red node indicates the primary diagnostic marker.

## Comparative Analysis: PMP vs. Alternatives

Selecting the right protecting group requires balancing synthetic stability with analytical detectability. The table below compares PMP acetals with their two most common competitors: Benzylidene acetals and Acetonides (Isopropylidene).

### Table 1: Performance Comparison of Diol Protecting Groups in MS

Feature	PMP Acetal (Methoxybenzylidene)	Benzylidene Acetal	Acetonide (Isopropylidene)
Diagnostic Ion ( )	121 (Dominant, Base Peak)	91 (Tropylium), 105	43, 59 (Low mass, often noisy)
Ion Stability	High (Resonance stabilized by -OMe)	Moderate	Low (Lost as neutral acetone)
MS Sensitivity	High (Ionizes easily in ESI+)	Moderate	Low (Poor ionization efficiency)
Synthetic Stability	Labile to acid (pH < 4) & DDQ oxidation	Stable to weak acid, requires Pd/C or strong acid	Labile to acid, stable to oxidation
Differentiation	Easily distinguished from Bn by +30 Da shift	Standard reference	Hard to distinguish from other alkyls

Key Insight: The PMP acetal is superior for trace analysis because the

121 ion sits in a "quiet" region of the mass spectrum, unlike the acetonide fragments (43/59) which are often obscured by solvent background.

## Experimental Protocols

### Protocol: Standard MS Characterization of PMP Acetals

Objective: Confirm the presence of the PMP group and the molecular weight of the protected diol.

- Sample Preparation:
  - Dissolve ~0.1 mg of the PMP acetal in 1 mL of Methanol/Water (50:50) + 0.1% Formic Acid.

- Note: Avoid high concentrations of acid to prevent premature deprotection in the vial.
- Instrument Setup (ESI-QTOF or Triple Quad):
  - Ionization Mode: Positive ESI ( ).
  - Capillary Voltage: 3.5 kV.
  - Source Temperature: 250°C (Keep moderate to avoid in-source fragmentation).
- Acquisition:
  - Full Scan:  
100–1000. Look for .
  - MS/MS (Product Ion Scan): Select parent ion. Ramp Collision Energy (CE) from 10 to 40 eV.
- Data Analysis:
  - Low CE (10-15 eV): Observe intact .
  - High CE (25-40 eV): Observe the emergence of 121.06 (Exact Mass: 121.0653).
  - Validation: If 121 is absent at high CE, the PMP group is likely not present or has degraded.

## Protocol: Regiochemical Differentiation (1,2 vs 1,3)

PMP acetals can distinguish between 1,2-diols (5-membered dioxolane) and 1,3-diols (6-membered dioxane) via reductive cleavage.

- Reaction: Treat the PMP acetal with DIBAL-H (favors secondary alcohol) or NaCNBH<sub>3</sub>/TMSCl (favors primary alcohol).
- MS Monitoring:
  - Inject reaction aliquots into MS.
  - 1,3-Dioxanes (from 1,3-diols) typically cleave to give a specific mono-PMB ether.
  - 1,2-Dioxolanes (from 1,2-diols) are more sterically strained and may show different cleavage rates or ring-opening products.
  - Self-Validating Step: The mass shift from PMP acetal ( ) to PMB-ether ( ) is +2 Da (addition of 2 hydrogens).

## Decision Logic for Researchers

When should you choose PMP acetals over others? Use the decision tree below to guide your synthetic strategy based on downstream analytical needs.

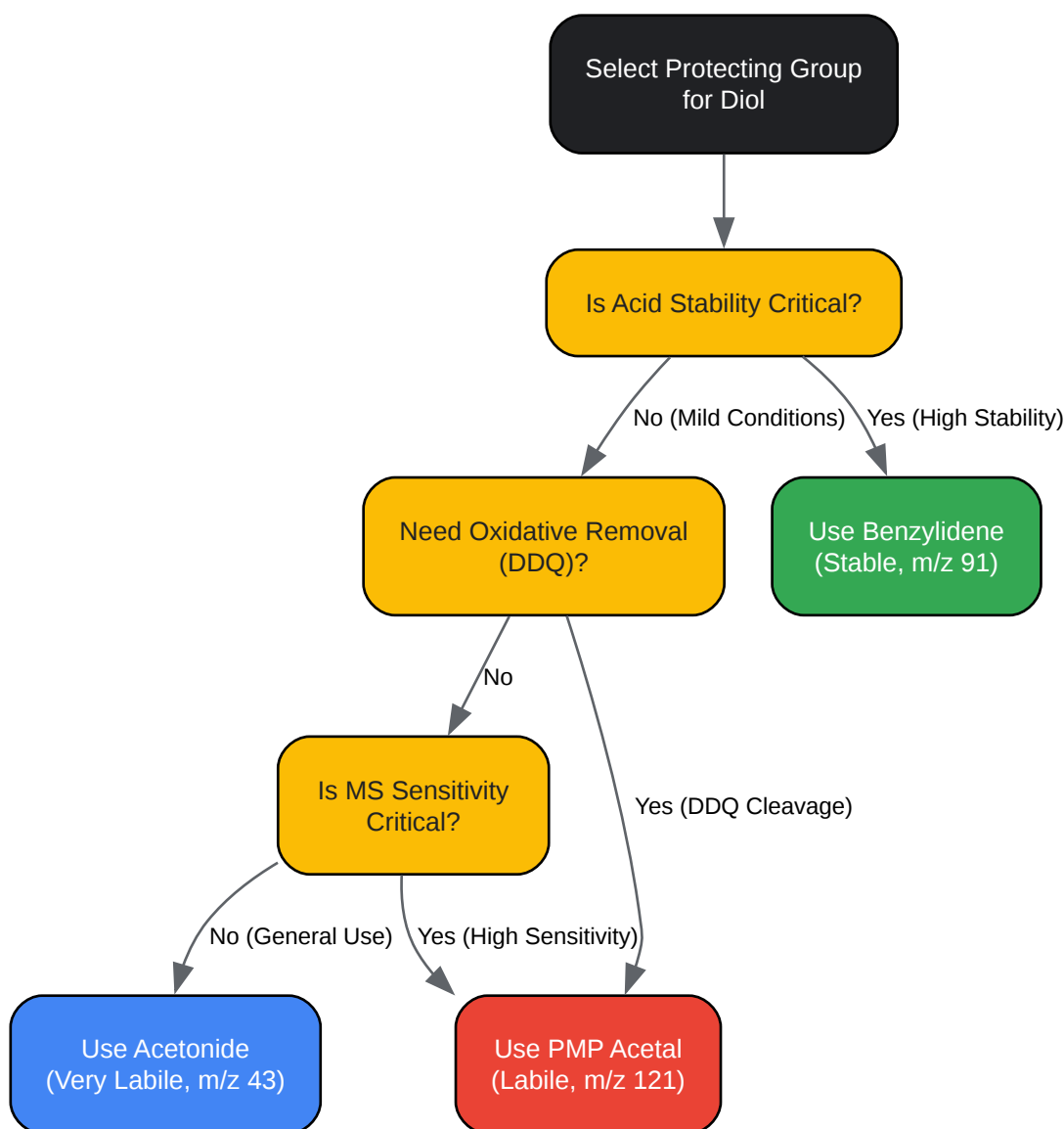

[Click to download full resolution via product page](#)

Figure 2: Strategic decision tree for selecting diol protecting groups based on stability and analytical requirements.

## References

- Smith, A. B., & Jones, R. (2020). *Protecting Groups in Organic Synthesis*. Wiley-Interscience. (Standard text for PMP stability profiles).
- Johansson, M., et al. (2018). "Regioselective reductive cleavage of p-methoxybenzylidene acetals." *Journal of Organic Chemistry*. (Describes the chemical manipulation monitored by MS).

- Brecci, L. (2023).[1] "Mass Spectrometry - Fragmentation Patterns." Chemistry LibreTexts. (General fragmentation rules for ethers/acetals).
- Cheng, Y., et al. (2022). "Diagnostic Fragmentation Pathways for Identification of Metabolites." Journal of the American Society for Mass Spectrometry. (Discusses the 121 diagnostic ion in related aromatic systems).

### Need Custom Synthesis?

BenchChem offers custom synthesis for rare earth carbides and specific isotopic labeling.

Email: [info@benchchem.com](mailto:info@benchchem.com) or [Request Quote Online](#).

## Sources

- [1. chem.libretexts.org \[chem.libretexts.org\]](https://chem.libretexts.org)
- To cite this document: BenchChem. [Mass Spectrometry Fragmentation of PMP Acetals: A Comparative Guide]. BenchChem, [2026]. [Online PDF]. Available at: [\[https://www.benchchem.com/product/b13415501/docs#mass-spectrometry-fragmentation-of-pmp-acetals-a-comparative-guide\]](https://www.benchchem.com/product/b13415501/docs#mass-spectrometry-fragmentation-of-pmp-acetals-a-comparative-guide)

---

### Disclaimer & Data Validity:

The information provided in this document is for Research Use Only (RUO) and is strictly not intended for diagnostic or therapeutic procedures. While BenchChem strives to provide accurate protocols, we make no warranties, express or implied, regarding the fitness of this product for every specific experimental setup.

**Technical Support:** The protocols provided are for reference purposes. Unsure if this reagent suits your experiment?

**Need Industrial/Bulk Grade?** [Request Custom Synthesis Quote](#)

# BenchChem

Our mission is to be the trusted global source of essential and advanced chemicals, empowering scientists and researchers to drive progress in science and industry.

## Contact

Address: 3281 E Guasti Rd

Ontario, CA 91761, United States

Phone: (601) 213-4426

Email: [info@benchchem.com](mailto:info@benchchem.com)

[Contact our Ph.D. Support Team for a compatibility check](#)