

Application Note: Solvent-Free Synthesis of Aryloxy Propanones[1]

Author: BenchChem Technical Support Team. **Date:** May 2026

Compound of Interest

Compound Name: *1-(3-Methoxyphenoxy)-2-propanone*

CAS No.: 6437-63-4

Cat. No.: B13412132

[Get Quote](#)

Executive Summary

Aryloxy propanones (specifically 1-aryloxy-2-propanones) are critical intermediates in the synthesis of

-adrenergic blockers (e.g., propranolol, acebutolol) and various agrochemicals. Traditional synthesis relies on the Williamson etherification of phenols with

-halo ketones in volatile organic solvents (acetone, acetonitrile) under reflux. These methods suffer from long reaction times (8–24 hours), moderate yields (40–60%), and significant hazardous waste generation.

This guide details two solvent-free protocols—Microwave-Assisted Organic Synthesis (MAOS) and Mechanochemical Grinding—that reduce reaction times to minutes and increase yields to >90%. Crucially, this note integrates the use of Potassium Iodide (KI) as a catalytic additive, a "field-proven" modification that drives the reaction via the in situ Finkelstein exchange, overcoming the poor electrophilicity of chloroacetone.

Scientific Foundation & Mechanism

The Challenge of Conventional Synthesis

The direct alkylation of phenols with chloroacetone is kinetically sluggish due to the moderate leaving group ability of chloride. In bulk solvent, solvation shells around the phenoxide anion further reduce nucleophilicity. Furthermore, chloroacetone is a potent lachrymator, making prolonged reflux hazardous.

The Solvent-Free Advantage

Removing the solvent creates a highly concentrated reaction matrix where the collision frequency between the phenoxide and the electrophile is maximized.

- Microwave (MW) Activation: Direct coupling of microwave energy with polar reagents (chloroacetone, phenoxide ion pairs) causes rapid internal heating, accelerating the rate significantly beyond convective heating.
- Mechanochemistry: Physical grinding generates "hot spots" and fresh surface area on the solid base (), promoting rapid deprotonation.

Mechanistic Pathway & Catalysis

The reaction follows an

pathway. To enhance the rate, we employ Potassium Iodide (KI). KI reacts with chloroacetone to form iodoacetone in situ. Since iodide is a better leaving group than chloride, the subsequent attack by phenoxide is much faster.

DOT Diagram 1: Catalytic Cycle & Reaction Mechanism

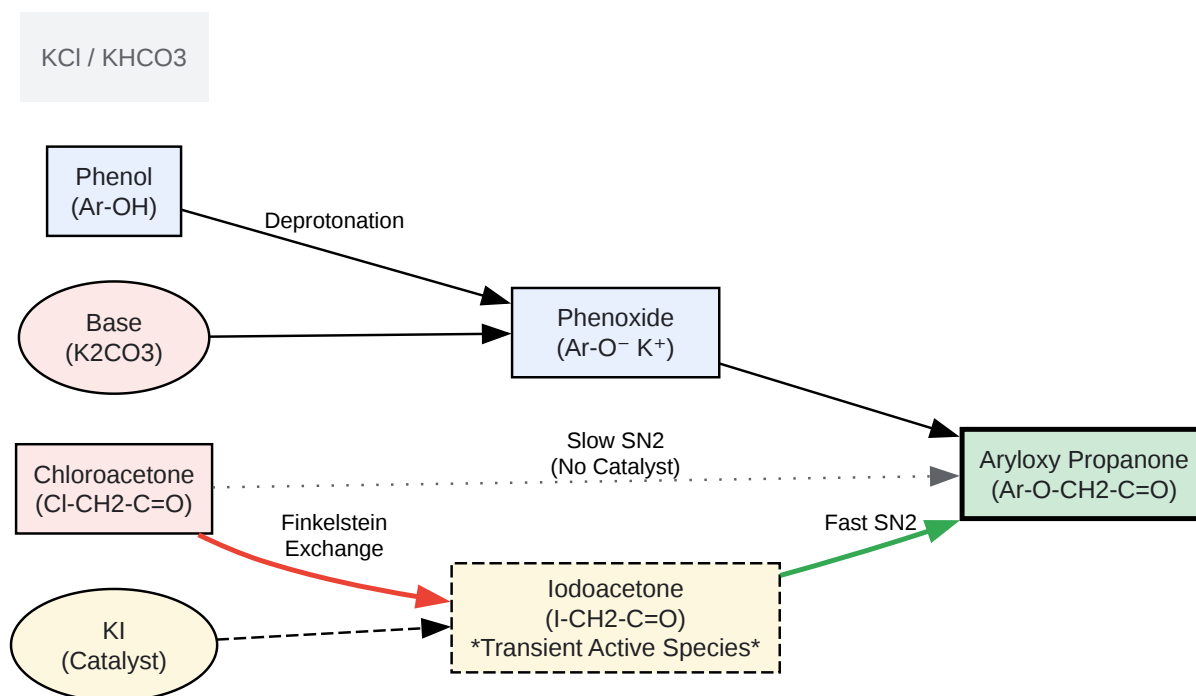

[Click to download full resolution via product page](#)

Caption: Mechanism showing the catalytic role of KI in converting Chloroacetone to the highly reactive Iodoacetone intermediate.

Experimental Protocols

Safety Pre-Requisites

- Chloroacetone: Potent lachrymator (tear gas). MUST be handled in a functioning fume hood. Neutralize spills with aqueous ammonia.
- Microwave Safety: Use only dedicated synthesis reactors (e.g., CEM, Anton Paar). Do not use domestic microwaves due to lack of pressure/temp control.

Method A: Microwave-Assisted Synthesis (High Throughput)

Best for: Rapid library synthesis, optimization studies.

Reagents:

- Substituted Phenol (1.0 equiv)
- Chloroacetone (1.1 equiv)
- Potassium Carbonate (, anhydrous, 2.0 equiv)[1]
- Potassium Iodide (KI, 0.1 equiv)
- Tetrabutylammonium Bromide (TBAB, 0.05 equiv) - Optional, acts as Phase Transfer Catalyst.

Protocol:

- Preparation: In a 10 mL microwave process vial, mix the Phenol (e.g., 10 mmol) and (20 mmol).
- Activation: Add Chloroacetone (11 mmol), KI (1 mmol), and TBAB (0.5 mmol). Cap the vial immediately to contain vapors.
- Irradiation: Place in the microwave reactor.
 - Temp: 100°C
 - Time: 5–10 minutes
 - Stirring: High
 - Power: Dynamic (Max 150W)
- Workup: Cool to RT. Add water (20 mL) to dissolve inorganic salts. The product often separates as an oil or solid.
 - Solid: Filter, wash with water, recrystallize (EtOH/Water).
 - Oil:[2] Extract with Ethyl Acetate (

mL), dry over

, evaporate.

Method B: Mechanochemical Grinding (Greenest Approach)

Best for: Large scale, energy efficiency, labs without MW reactors.

Reagents:

- Substituted Phenol (1.0 equiv)
- Chloroacetone (1.1 equiv)
- Potassium Hydroxide (KOH) or
(2.0 equiv)
- KI (0.1 equiv)

Protocol:

- Grinding: Place Phenol and Base in a mortar. Grind with a pestle for 2–3 minutes until a fine, uniform powder/paste forms (formation of phenoxide).
- Addition: Add KI and Chloroacetone dropwise to the paste.
- Reaction: Grind vigorously for 10–20 minutes.
 - Observation: The mixture will likely become sticky or liquefy (eutectic formation) and may generate heat (exothermic).
 - Monitoring: Check TLC (Hexane:EtOAc 8:2) every 5 mins.
- Workup: Transfer the paste to a beaker containing ice water (50 mL). Stir well. Filter the precipitated solid product.[\[3\]](#)

Representative Data & Comparison

The following table summarizes typical results comparing traditional reflux methods with the protocols defined above.

Parameter	Conventional Reflux	Method A: Microwave	Method B: Grinding
Solvent	Acetone (Volatile, VOC)	None (Solvent-Free)	None (Solvent-Free)
Catalyst	None	KI + TBAB	KI
Time	8 – 16 Hours	5 – 10 Minutes	15 – 30 Minutes
Yield	45 – 60%	92 – 96%	85 – 92%
Energy	High (Prolonged Heating)	Low (Targeted Heating)	Very Low (Manual/Mill)
Workup	Solvent evaporation required	Simple water precipitation	Simple water precipitation

Workflow Visualization

DOT Diagram 2: Experimental Workflow Decision Tree

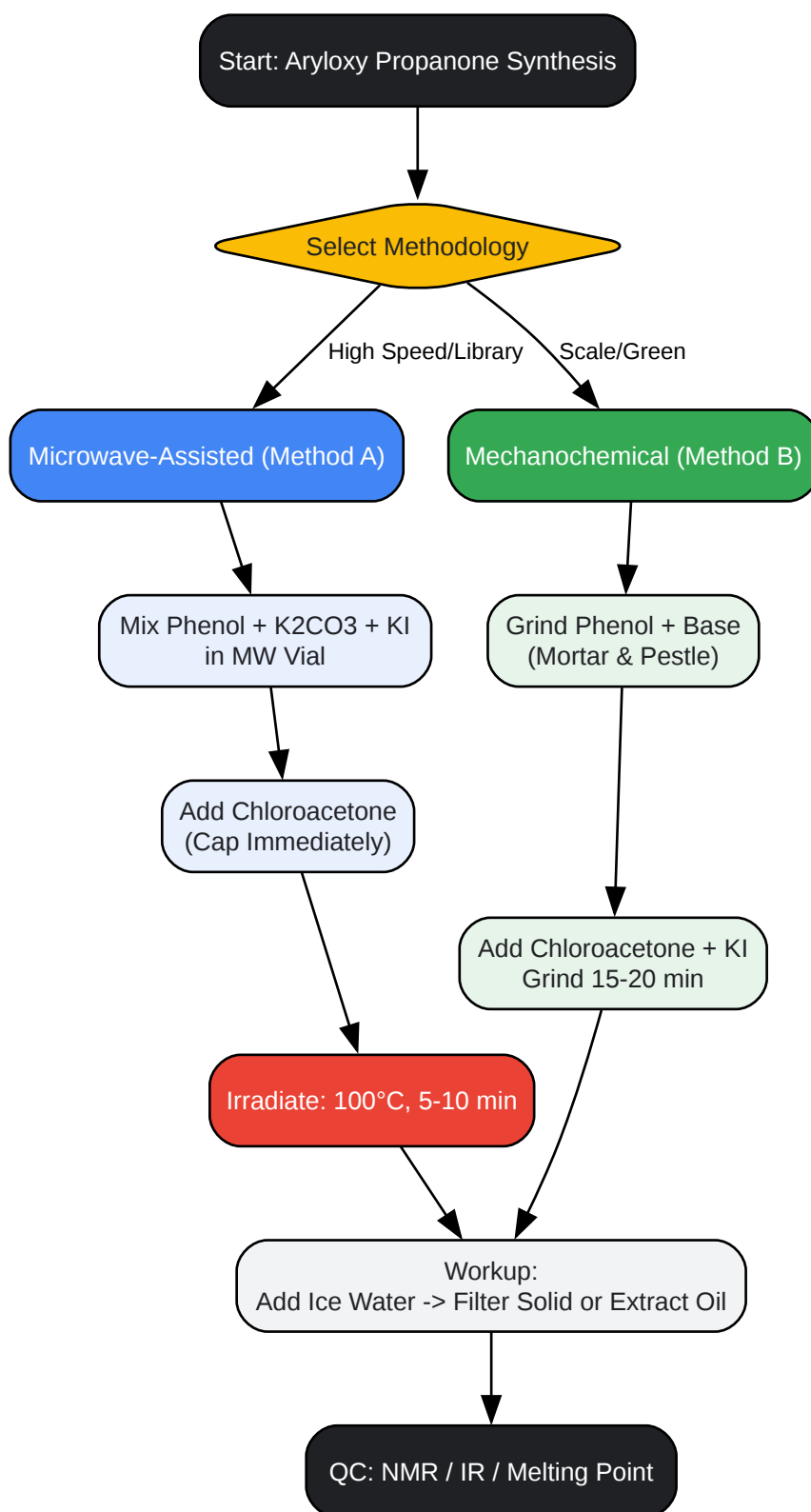

[Click to download full resolution via product page](#)

Caption: Decision matrix and process flow for selecting and executing solvent-free synthesis.

Troubleshooting & QC

- Low Yield:
 - Cause: Chloroacetone degradation or moisture in
.
 - Fix: Use freshly distilled chloroacetone. Dry
in an oven at 120°C before use. Ensure KI is added; without it, the reaction is significantly slower.
- O- vs C-Alkylation:
 - Issue: Phenols can undergo C-alkylation (on the ring).
 - Control: The use of hard bases like
and polar aprotic conditions (or solvent-free) favors O-alkylation. If C-alkylation is observed, ensure the mixture is not overheated (>120°C).
- Sticky Paste (Grinding):
 - Issue: Reaction mixture becomes too viscous to grind.
 - Fix: Add a small quantity (drops) of glycerol or PEG-400 as a green grinding auxiliary (Liquid Assisted Grinding - LAG).

References

- Microwave-Assisted Synthesis of Phenoxyacetalides: Title: Microwave Assisted Synthesis of New Phenoxyacetalides Bearing Anaesthetic Properties.[4] Source: ResearchGate (2025). URL:[[Link](#)] (Validates MW efficiency for phenoxide alkylation).
- General Solvent-Free Protocols: Title: Microwave-Assisted Organic Synthesis: An Eco-Friendly Method of Green Chemistry. Source: MDPI (2025). URL:[[Link](#)] (Authoritative source on Green Chemistry principles and MW safety).

- Mechanistic Insight (KI Catalysis): Title: Aryloxyacetones - Sciencemadness Discussion (Historical/Practical Data). Source: Sciencemadness.org. URL:[[Link](#)] (Provides critical practical insight into the KI/Finkelstein modification for this specific substrate).
- Solid-State/Grinding Synthesis: Title: A Facile Solvent Free Synthesis of 3-arylidenechroman-4-ones Using Grinding Technique. Source: E-Journal of Chemistry (via ResearchGate). URL:[[Link](#)] (Validates the grinding protocol for similar aryloxy precursors).

Need Custom Synthesis?

BenchChem offers custom synthesis for rare earth carbides and specific isotopic labeling.

Email: info@benchchem.com or [Request Quote Online](#).

Sources

- 1. [rsc.org](https://www.rsc.org) [[rsc.org](https://www.rsc.org)]
- 2. [journal.nsps.org.ng](https://www.journal.nsps.org.ng) [[journal.nsps.org.ng](https://www.journal.nsps.org.ng)]
- 3. [pdfs.semanticscholar.org](https://www.pdfsemanticscholar.org) [[pdfs.semanticscholar.org](https://www.pdfsemanticscholar.org)]
- 4. [researchgate.net](https://www.researchgate.net) [[researchgate.net](https://www.researchgate.net)]
- To cite this document: BenchChem. [Application Note: Solvent-Free Synthesis of Aryloxy Propanones[1]]. BenchChem, [2026]. [Online PDF]. Available at: [<https://www.benchchem.com/product/b13412132/docs#application-note-solvent-free-synthesis-of-aryloxy-propanones-1>]

Disclaimer & Data Validity:

The information provided in this document is for Research Use Only (RUO) and is strictly not intended for diagnostic or therapeutic procedures. While BenchChem strives to provide accurate protocols, we make no warranties, express or implied, regarding the fitness of this product for every specific experimental setup.

Technical Support: The protocols provided are for reference purposes. Unsure if this reagent suits your experiment?

Need Industrial/Bulk Grade? [Request Custom Synthesis Quote](#)

BenchChem

Our mission is to be the trusted global source of essential and advanced chemicals, empowering scientists and researchers to drive progress in science and industry.

Contact

Address: 3281 E Guasti Rd
Ontario, CA 91761, United States
Phone: (601) 213-4426
Email: info@benchchem.com

[Contact our Ph.D. Support Team for a compatibility check](#)