

# Introduction: The GABAA Receptor as a Therapeutic Target

**Author:** BenchChem Technical Support Team. **Date:** April 2026

## Compound of Interest

Compound Name: NS5818  
Cat. No.: B13411943

[Get Quote](#)

The  $\gamma$ -aminobutyric acid type A (GABAA) receptor is the principal mediator of fast inhibitory neurotransmission in the central nervous system (CNS).[1] These receptors are ligand-gated ion channels that, upon binding the neurotransmitter GABA, open an intrinsic chloride ( $\text{Cl}^-$ ) channel.[2] The resulting influx of chloride ions hyperpolarizes the neuron, reducing its excitability and the likelihood of firing an action potential.[1][2] This fundamental role in regulating neuronal activity makes the GABAA receptor a critical therapeutic target for a host of neurological and psychiatric conditions, including anxiety, epilepsy, sleep disorders, and depression.[3][4]

Positive Allosteric Modulators (PAMs) are compounds that do not activate the receptor directly but bind to a distinct allosteric site, enhancing the effect of the endogenous ligand, GABA.[1] This modulation provides a mechanism for fine-tuning inhibitory neurotransmission. Classical PAMs, such as benzodiazepines (e.g., Diazepam), have been cornerstone therapies for decades but are associated with undesirable side effects like sedation, cognitive impairment, and dependence, largely due to their non-selective action across various GABAA receptor subtypes.[3][5]

The GABAA receptor is a heteropentameric complex assembled from a diverse family of 19 subunits (e.g.,  $\alpha$ ,  $\beta$ ,  $\gamma$ ). The specific subunit composition dictates the receptor's location,

physiological function, and pharmacological properties. For instance,  $\alpha 1$ -containing receptors are linked to sedation, while  $\alpha 2/\alpha 3$  subunits are associated with anxiolytic effects.[5][6] This heterogeneity offers a compelling opportunity for modern drug discovery: the development of novel, subtype-selective PAMs that can deliver targeted therapeutic benefits with an improved safety profile. This guide details the core methodologies, from initial discovery and chemical synthesis to rigorous characterization, that underpin the development of the next generation of GABAA PAMs.

## Discovery of Novel PAMs: Screening Strategies

The identification of new GABAA PAMs begins with screening large libraries of chemical compounds to find "hits" that modulate receptor activity. Modern discovery workflows integrate both computational and experimental techniques for efficient hit identification.[7][8]

### High-Throughput Screening (HTS)

High-Throughput Screening (HTS) enables the rapid evaluation of thousands of compounds.[1] A common approach for GABAA receptors is the use of fluorescence-based assays that measure changes in neuronal membrane potential.[1][9]

A typical HTS workflow involves several stages, from initial screening to hit confirmation and lead optimization. This process is designed to systematically filter a large chemical library down to a few promising candidates for further development.

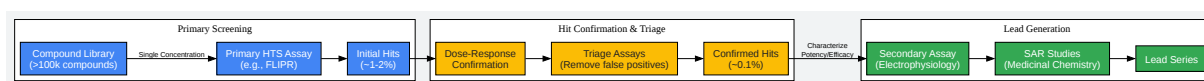

[Click to download full resolution via product page](#)

Caption: A typical drug discovery workflow for identifying novel GABA<sub>A</sub> PAMs.

### In Silico and Structure-Based Design

Computational methods, or in silico screening, are increasingly used to identify potential PAMs.[7][8] This can involve virtual screening of compound databases against a homology model of the GABAA receptor.[10] As high-resolution structures of GABAA receptors in complex with modulators become available, structure-based drug design allows for the rational optimization of hit compounds to improve their affinity, selectivity, and pharmacokinetic properties.[8]

## Synthesis of Novel GABAA PAMs

Once a promising chemical scaffold is identified, medicinal chemists synthesize a series of analogues to explore the structure-activity relationship (SAR) and optimize the compound's properties. Imidazobenzodiazepines, imidazopyridazines, and pyrazoloquinolinones are examples of heterocyclic scaffolds that have been successfully developed into novel, subtype-selective PAMs.[\[11\]](#)[\[12\]](#)[\[13\]](#)

The synthesis of these complex molecules often involves multi-step reaction sequences. For example, the synthesis of an imidazobenzodiazepine core might start from commercially available materials and proceed through several key transformations, such as condensation, cyclization, and functional group modification, to build the final molecule.[\[14\]](#)

For instance, the synthesis of the novel anxiolytic KRM-II-81, an oxazole derivative, was achieved from an imidazobenzodiazepine precursor via a two-step reduction-oxidation protocol to form a key aldehyde intermediate, which was then used to construct the final oxazole ring.[\[14\]](#) Such synthetic efforts aim to fine-tune the molecule's interaction with specific residues within the GABAA receptor's allosteric binding site, thereby conferring subtype selectivity.

## Characterization of Novel PAMs: Key Experiments

Rigorous characterization is essential to determine the potency, efficacy, selectivity, and mechanism of action of newly synthesized compounds. This involves a suite of in vitro assays.

### Signaling Pathway

GABAA PAMs enhance the receptor's response to GABA. The binding of GABA to its orthosteric site between the  $\alpha$  and  $\beta$  subunits triggers the opening of the chloride channel. PAMs, such as benzodiazepines and newer subtype-selective compounds, bind to a different site—typically the interface between the  $\alpha$  and  $\gamma$  subunits—and allosterically increase the channel's opening frequency or duration in the presence of GABA, thereby potentiating the inhibitory current.[\[1\]](#)[\[2\]](#)

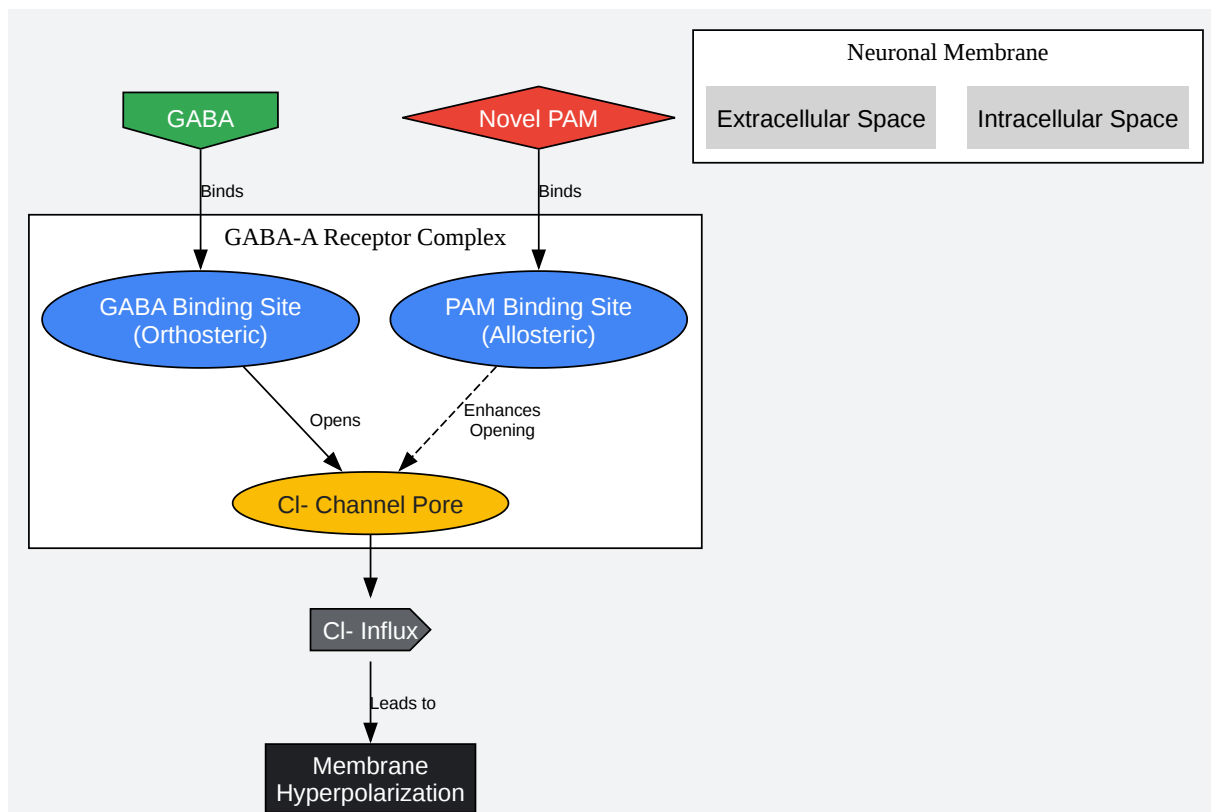

[Click to download full resolution via product page](#)

Caption: Simplified signaling pathway of a GABA<sub>A</sub> receptor modulated by a PAM.

## Quantitative Data of Novel PAMs

The pharmacological properties of novel PAMs are quantified to compare their potency and subtype selectivity. Binding affinity (K<sub>i</sub>) indicates how tightly a compound binds to the receptor, while functional potentiation (EC<sub>50</sub> and % potentiation) measures its effect on GABA-evoked currents. The tables below summarize representative data for novel subtype-selective PAMs.

Table 1: Binding Affinities (K<sub>i</sub>, nM) of Novel PAMs at Different α-Subtype Receptors

Compound	$\alpha 1\beta 3\gamma 2$	$\alpha 2\beta 3\gamma 2$	$\alpha 3\beta 3\gamma 2$	$\alpha 5\beta 3\gamma 2$	Reference
PF-06372865	0.82	0.49	0.44	2.1	[12]
MRK-409	0.40	0.21	0.23	0.32	[6]
TPA023	2.0	0.54	0.53	2.3	[6]
(+)-ROD188*	>30,000	>30,000	>30,000	>30,000	[15]

\*Note: (+)-ROD188 acts at a novel site distinct from the benzodiazepine site, hence its low affinity in [<sup>3</sup>H]Flumazenil binding assays.

Table 2: Functional Potentiation of Novel PAMs

Compound	Receptor Subtype	EC50 (nM)	Max Potentiation (% of GABA response)	Reference
PF-06372865	$\alpha 2\beta 3\gamma 2$	11	~50%	[6][12]
	$\alpha 3\beta 3\gamma 2$	3.5	~50%	[6][12]
	$\alpha 1\beta 3\gamma 2$	190	~10%	[6][12]
TPA023	$\alpha 2\beta 2\gamma 2$	3.1	~40%	[16]
	$\alpha 3\beta 2\gamma 2$	2.3	~40%	[16]

| |  $\alpha 1\beta 2\gamma 2$  | 150 | ~5% (Negligible) |[16] |

## Experimental Protocols

Detailed and reproducible protocols are the bedrock of drug characterization. The following sections describe standard methodologies for assessing the binding and functional effects of novel GABAA PAMs.

## Radioligand Binding Assay

This assay determines the binding affinity ( $K_i$ ) of a test compound by measuring its ability to displace a specific radioligand from the receptor. For the benzodiazepine binding site, [ $^3\text{H}$ ]Flunitrazepam or [ $^3\text{H}$ ]Ro 15-1788 are commonly used.[17][18]

Objective: To determine the  $K_i$  of a novel compound at specific GABAA receptor subtypes expressed in cell membranes.

Methodology:

- Membrane Preparation:
  - Culture HEK293 cells stably expressing the desired GABAA receptor subunit combination (e.g.,  $\alpha 1\beta 2\gamma 2$ ).
  - Harvest cells and homogenize in a cold buffer (e.g., 50 mM Tris-HCl, pH 7.4).
  - Perform a series of centrifugations to isolate the cell membrane fraction.[19] The final pellet is resuspended in the binding buffer and protein concentration is determined.[19]
- Binding Reaction:
  - In a 96-well plate, incubate the prepared membranes with a fixed concentration of radioligand (e.g., 2 nM [ $^3\text{H}$ ]Flunitrazepam).[18]
  - Add varying concentrations of the unlabeled test compound.
  - To determine non-specific binding, a separate set of wells includes a high concentration of a known non-radioactive ligand (e.g., 5  $\mu\text{M}$  Diazepam).[18]
  - Incubate the plate at 4°C for 60-90 minutes to reach equilibrium.[18]
- Termination and Detection:
  - Rapidly terminate the reaction by filtering the contents of each well through a glass fiber filter mat using a cell harvester. This separates the bound radioligand from the unbound.
  - Wash the filters multiple times with ice-cold buffer to remove any remaining unbound radioligand.[18]

- Measure the radioactivity retained on the filters using a liquid scintillation counter.
- Data Analysis:
  - Calculate specific binding by subtracting non-specific binding from total binding.
  - Plot the percentage of specific binding against the logarithm of the test compound concentration.
  - Fit the data to a sigmoidal dose-response curve to determine the IC50 value (the concentration of test compound that displaces 50% of the radioligand).
  - Convert the IC50 to a Ki value using the Cheng-Prusoff equation.

## Two-Electrode Voltage Clamp (TEVC) Electrophysiology

TEVC is a robust technique for studying the function of ion channels expressed in large cells, such as *Xenopus laevis* oocytes.<sup>[11][20]</sup> It allows for precise control of the cell's membrane potential while measuring the currents flowing through the expressed GABAA receptors.

Objective: To measure the potentiation of GABA-induced chloride currents by a novel PAM.

Methodology:

- Oocyte Preparation:
  - Harvest oocytes from a female *Xenopus laevis* frog.
  - Inject the oocytes with cRNAs encoding the desired  $\alpha$ ,  $\beta$ , and  $\gamma$  subunits of the GABAA receptor.
  - Incubate the oocytes for 2-5 days to allow for receptor expression on the cell surface.
- Recording Setup:
  - Place a single oocyte in a recording chamber continuously perfused with a buffer solution (e.g., Ringer's solution).

- Impale the oocyte with two microelectrodes filled with KCl: one to measure the membrane voltage and one to inject current.[20][21]
- Use a voltage-clamp amplifier to hold the oocyte's membrane potential at a fixed value (e.g., -60 mV).[22]
- Data Acquisition:
  - Establish a baseline current by perfusing the chamber with buffer.
  - Apply a low, non-saturating concentration of GABA (e.g., an EC<sub>5</sub>-EC<sub>20</sub> concentration) to elicit a stable inward chloride current.[23]
  - Once the GABA response reaches a steady state, co-apply the same concentration of GABA along with the test compound (novel PAM).
  - Record the change in current. An increase in the inward current indicates positive modulation.[24]
  - Wash out the compounds with buffer to allow the current to return to baseline.
- Data Analysis:
  - Measure the peak current amplitude in the presence of GABA alone and in the presence of GABA plus the PAM.
  - Calculate the percent potentiation.
  - Repeat the procedure with varying concentrations of the PAM to construct a dose-response curve and determine its EC<sub>50</sub> value.

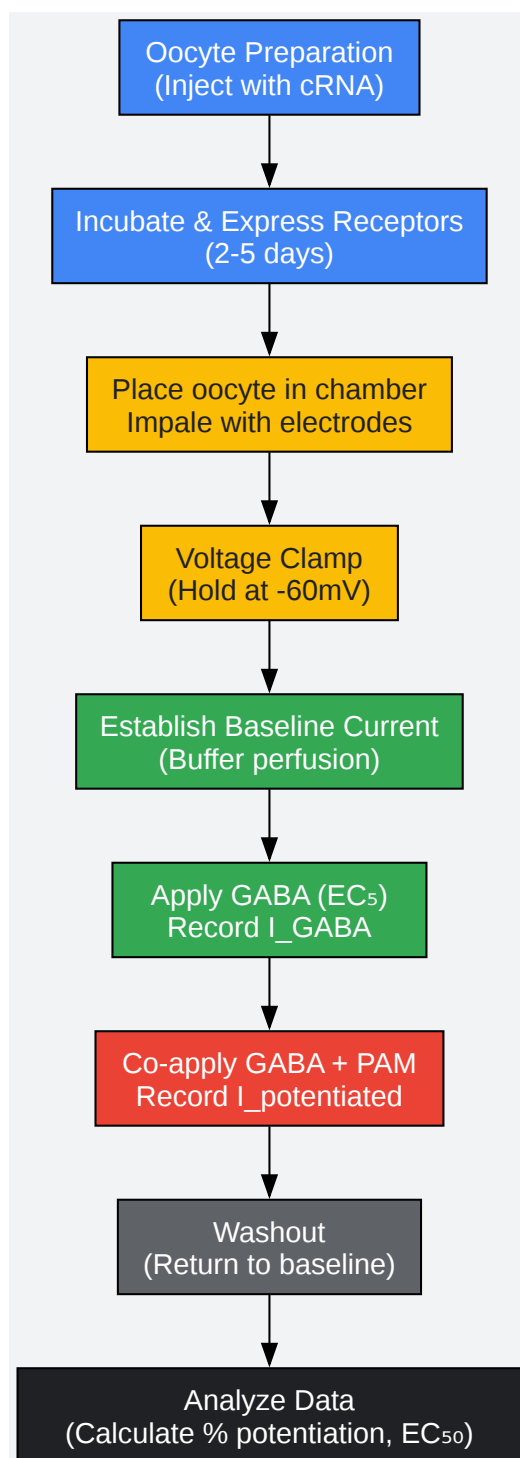

[Click to download full resolution via product page](#)

Caption: Experimental workflow for a Two-Electrode Voltage Clamp (TEVC) assay.

## Conclusion and Future Directions

The discovery and development of novel GABAA PAMs have shifted from a paradigm of broad-spectrum activity to one of targeted, subtype-selective modulation. By leveraging integrated discovery platforms that combine high-throughput screening with structure-based design, researchers are identifying novel chemical entities with greater precision. Rigorous characterization using electrophysiology and binding assays is crucial for elucidating the pharmacological profiles of these compounds, paving the way for PAMs with improved therapeutic windows.

Future efforts will likely focus on developing PAMs with even greater subtype selectivity, including those that target extrasynaptic  $\delta$ -containing receptors or novel allosteric sites. The continued elucidation of high-resolution GABAA receptor structures will undoubtedly accelerate these efforts, enabling the rational design of next-generation therapeutics to treat a wide range of debilitating neurological and psychiatric disorders.

#### *Need Custom Synthesis?*

*BenchChem offers custom synthesis for rare earth carbides and specific isotopic labeling.*

*Email: [info@benchchem.com](mailto:info@benchchem.com) or [Request Quote Online](#).*

## References

- [1. benchchem.com \[benchchem.com\]](https://www.benchchem.com)
- [2. GABA receptor - Wikipedia \[en.wikipedia.org\]](https://en.wikipedia.org/wiki/GABA_receptor)
- [3. GABAkinases - Advances in the discovery, development, and commercialization of positive allosteric modulators of GABAA receptors - PubMed \[pubmed.ncbi.nlm.nih.gov\]](https://pubmed.ncbi.nlm.nih.gov/)
- [4. Synthesis and Receptor Binding Studies of  \$\alpha 5\$  GABAAR Selective Novel Imidazodiazepines Targeted for Psychiatric and Cognitive Disorders - PMC \[pmc.ncbi.nlm.nih.gov\]](https://pmc.ncbi.nlm.nih.gov/)
- [5. Part I: Design and Synthesis of Novel Drugs to Treat Asthma By Targeting GABAA Receptors in the Lung Part II: Design and Synthesis of Novel  \$A2/\alpha 3\$  Subtype Selective GABAAR Ligands for CNS Disorders \[minds.wisconsin.edu\]](https://minds.wisconsin.edu/)
- [6. orca.cardiff.ac.uk \[orca.cardiff.ac.uk\]](https://orca.cardiff.ac.uk/)
- [7. Integrated workflow for the identification of new GABAA R positive allosteric modulators based on the in silico screening with further in vitro validation. Case study using Enamine's](#)

stock chemical space - PubMed [[pubmed.ncbi.nlm.nih.gov](https://pubmed.ncbi.nlm.nih.gov)]

- 8. [researchgate.net](https://www.researchgate.net) [[researchgate.net](https://www.researchgate.net)]
- 9. Establishment of a High Throughput Screening System for GABAA1 Modulators in Living Cells - PubMed [[pubmed.ncbi.nlm.nih.gov](https://pubmed.ncbi.nlm.nih.gov)]
- 10. Discovery of Novel GABAAR Allosteric Modulators Through Reinforcement Learning - PubMed [[pubmed.ncbi.nlm.nih.gov](https://pubmed.ncbi.nlm.nih.gov)]
- 11. Identification of novel positive allosteric modulators and null modulators at the GABAA receptor  $\alpha+\beta$ - interface - PubMed [[pubmed.ncbi.nlm.nih.gov](https://pubmed.ncbi.nlm.nih.gov)]
- 12. [pubs.acs.org](https://pubs.acs.org) [[pubs.acs.org](https://pubs.acs.org)]
- 13. Allosteric GABAA Receptor Modulators—A Review on the Most Recent Heterocyclic Chemotypes and Their Synthetic Accessibility - PMC [[pmc.ncbi.nlm.nih.gov](https://pubmed.ncbi.nlm.nih.gov)]
- 14. Synthesis and characterization of a novel gamma-aminobutyric acid type A (GABAA) receptor ligand that combines outstanding metabolic stability, pharmacokinetics, and anxiolytic efficacy - PMC [[pmc.ncbi.nlm.nih.gov](https://pubmed.ncbi.nlm.nih.gov)]
- 15. A novel positive allosteric modulator of the GABAA receptor: the action of (+)-ROD188 - PMC [[pmc.ncbi.nlm.nih.gov](https://pubmed.ncbi.nlm.nih.gov)]
- 16. [researchgate.net](https://www.researchgate.net) [[researchgate.net](https://www.researchgate.net)]
- 17. Saturation assays of radioligand binding to receptors and their allosteric modulatory sites - PubMed [[pubmed.ncbi.nlm.nih.gov](https://pubmed.ncbi.nlm.nih.gov)]
- 18. GABAA Receptor Ligands Often Interact with Binding Sites in the Transmembrane Domain and in the Extracellular Domain—Can the Promiscuity Code Be Cracked? - PMC [[pmc.ncbi.nlm.nih.gov](https://pubmed.ncbi.nlm.nih.gov)]
- 19. PDSP - GABA [[kidbdev.med.unc.edu](https://www.kidbdev.med.unc.edu)]
- 20. [researchgate.net](https://www.researchgate.net) [[researchgate.net](https://www.researchgate.net)]
- 21. [biophys.uni-frankfurt.de](https://www.biophys.uni-frankfurt.de) [[biophys.uni-frankfurt.de](https://www.biophys.uni-frankfurt.de)]
- 22. [researchgate.net](https://www.researchgate.net) [[researchgate.net](https://www.researchgate.net)]
- 23. [researchgate.net](https://www.researchgate.net) [[researchgate.net](https://www.researchgate.net)]
- 24. Modulation of the mammalian GABAA receptor by type I and type II positive allosteric modulators of the  $\alpha 7$  nicotinic acetylcholine receptor - PMC [[pmc.ncbi.nlm.nih.gov](https://pubmed.ncbi.nlm.nih.gov)]
- To cite this document: BenchChem. [Introduction: The GABAA Receptor as a Therapeutic Target]. BenchChem, [2026]. [Online PDF]. Available at: [<https://www.benchchem.com/product/b13411943/docs#introduction-the-gabaa-receptor-as-a-therapeutic-target>]

**Disclaimer & Data Validity:**

The information provided in this document is for Research Use Only (RUO) and is strictly not intended for diagnostic or therapeutic procedures. While BenchChem strives to provide accurate protocols, we make no warranties, express or implied, regarding the fitness of this product for every specific experimental setup.

**Technical Support:** The protocols provided are for reference purposes. Unsure if this reagent suits your experiment?

**Need Industrial/Bulk Grade?** [Request Custom Synthesis Quote](#)

## BenchChem

Our mission is to be the trusted global source of essential and advanced chemicals, empowering scientists and researchers to drive progress in science and industry.

### Contact

Address: 3281 E Guasti Rd

Ontario, CA 91761, United States

Phone: (601) 213-4426

Email: [info@benchchem.com](mailto:info@benchchem.com)

[Contact our Ph.D. Support Team for a compatibility check](#)