

# Mass spectrometry fragmentation pattern of 2-(2-Bromophenoxy)-N-methylethanamine

**Author:** BenchChem Technical Support Team. **Date:** May 2026

## Compound of Interest

Compound Name: 2-(2-Bromophenoxy)-N-methylethanamine

CAS No.: 915920-44-4

Cat. No.: B1341840

[Get Quote](#)

An In-Depth Guide to the Mass Spectrometry Fragmentation of **2-(2-Bromophenoxy)-N-methylethanamine**: A Comparative Analysis

## Introduction

**2-(2-Bromophenoxy)-N-methylethanamine** is a molecule of interest in synthetic chemistry and drug discovery, often serving as a building block for more complex pharmaceutical agents. Accurate structural confirmation is paramount in these fields, and mass spectrometry (MS) is an indispensable tool for this purpose. Understanding the fragmentation pattern of a molecule under ionization provides a unique fingerprint, allowing for its unambiguous identification and differentiation from structural isomers and related compounds.

This guide serves as a technical resource for researchers and scientists, offering a detailed analysis of the expected mass spectrometry fragmentation pattern of **2-(2-Bromophenoxy)-N-methylethanamine**. We will explore the primary cleavage pathways under Electron Ionization (EI), compare its fragmentation with that of structural analogues, and provide a standardized protocol for experimental verification.

## Theoretical Fragmentation Pathways

The structure of **2-(2-Bromophenoxy)-N-methylethanamine** contains several key features that dictate its fragmentation behavior: a brominated aromatic ring, an ether linkage, and a secondary amine side chain. The interplay of these functional groups leads to a predictable and informative mass spectrum. The molecular ion ( $M^+$ ) for this compound will exhibit a characteristic isotopic signature due to the presence of bromine, which has two major isotopes,  $^{79}\text{Br}$  and  $^{81}\text{Br}$ , in nearly a 1:1 natural abundance.<sup>[1][2]</sup> This results in two molecular ion peaks of almost equal intensity at  $m/z$  229 and 231.

The most probable fragmentation pathways are driven by the formation of the most stable positive ions.<sup>[3][4]</sup>

- **Alpha-Cleavage ( $\alpha$ -Cleavage):** This is the most characteristic fragmentation pathway for aliphatic amines.<sup>[5][6]</sup> The cleavage of the carbon-carbon bond adjacent (alpha) to the nitrogen atom results in the formation of a highly stable, resonance-stabilized iminium cation.<sup>[3]</sup> For **2-(2-Bromophenoxy)-N-methylethanamine**, this is the predominant fragmentation, leading to the formation of the base peak.
- **Ether Linkage Cleavage:** The C-O bonds of the ether can also cleave. The most likely scenario is the cleavage of the alkyl C-O bond, which is weaker than the aryl C-O bond, leading to the formation of a bromophenoxy cation.
- **Benzylic-type Cleavage:** Cleavage of the bond between the ether oxygen and the ethyl side chain is another favorable pathway, resulting in a stable bromophenoxy radical and a charged amine fragment.
- **Loss of Halogen:** Direct loss of the bromine radical from the molecular ion is a common fragmentation route for halogenated compounds.<sup>[1]</sup>

The primary fragmentation pathways are visualized in the diagram below.

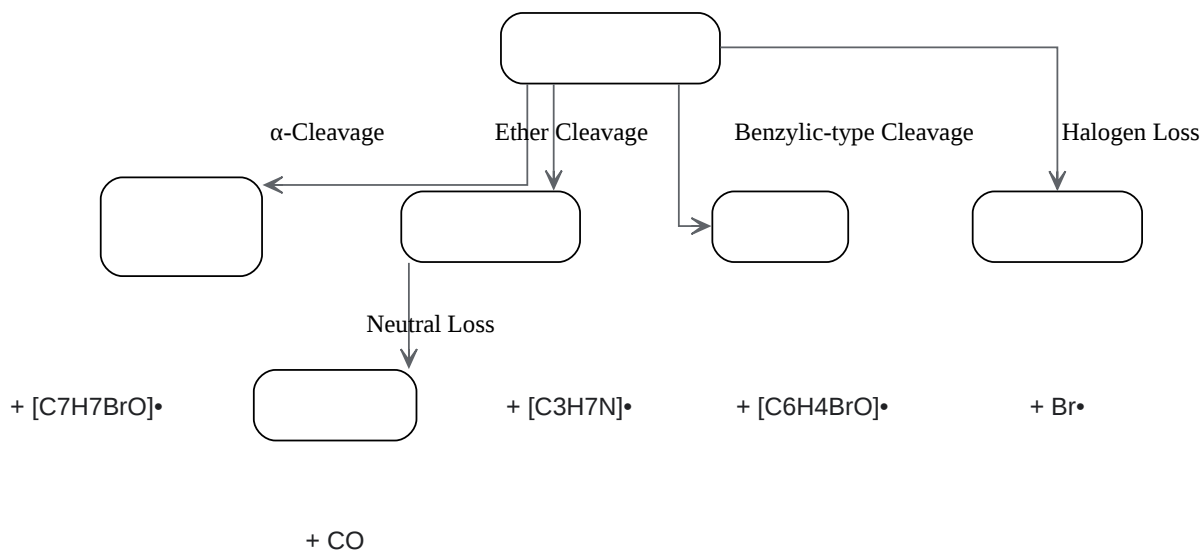

[Click to download full resolution via product page](#)

Caption: Predicted EI fragmentation of **2-(2-Bromophenoxy)-N-methylethanamine**.

## Comparative Fragmentation Analysis

To fully appreciate the unique fragmentation signature, it is instructive to compare it with structurally related molecules.

m/z (Ion)	2-(2-Bromophenoxy)-N-methylethanamine (Target)	2-Phenoxy-N-methylethanamine (Non-halogenated Analogue)	2-(2-Bromophenoxy)ethylanamine (Primary Amine Analogue)
Molecular Ion	229/231 (Distinct 1:1 isotope pattern)	151 (Single peak)	215/217 (Distinct 1:1 isotope pattern)
Base Peak	44 ([CH <sub>2</sub> =NHCH <sub>3</sub> ] <sup>+</sup> )	44 ([CH <sub>2</sub> =NHCH <sub>3</sub> ] <sup>+</sup> )	30 ([CH <sub>2</sub> =NH <sub>2</sub> ] <sup>+</sup> )
Key Fragments	171/173 ([BrC <sub>6</sub> H <sub>4</sub> O] <sup>+</sup> )	93 ([C <sub>6</sub> H <sub>5</sub> O] <sup>+</sup> )	171/173 ([BrC <sub>6</sub> H <sub>4</sub> O] <sup>+</sup> )
58 ([CH <sub>2</sub> CH <sub>2</sub> NHCH <sub>3</sub> ] <sup>+</sup> )	58 ([CH <sub>2</sub> CH <sub>2</sub> NHCH <sub>3</sub> ] <sup>+</sup> )	44 ([CH <sub>2</sub> CH <sub>2</sub> NH <sub>2</sub> ] <sup>+</sup> )	
155/157 ([BrC <sub>6</sub> H <sub>4</sub> ] <sup>+</sup> )	77 ([C <sub>6</sub> H <sub>5</sub> ] <sup>+</sup> )	155/157 ([BrC <sub>6</sub> H <sub>4</sub> ] <sup>+</sup> )	
150 ([M-Br] <sup>+</sup> )	N/A	136 ([M-Br] <sup>+</sup> )	

#### Analysis of Comparisons:

- **Effect of the Bromine Atom:** The most obvious difference is the presence of the M/M+2 isotopic pattern in the bromine-containing compounds, which is a powerful diagnostic tool.<sup>[1]</sup> <sup>[2]</sup> The bromine also directs fragmentation, enabling the loss of a Br radical. Comparing the target molecule to its non-halogenated analogue, we see that fragments containing the aromatic ring are shifted by the mass of bromine (78/80 Da).
- **Effect of N-Methylation:** Comparing the target molecule (a secondary amine) with its primary amine analogue reveals a critical difference in the base peak. The alpha-cleavage of the secondary amine yields a fragment at m/z 44, while the primary amine produces a characteristic fragment at m/z 30.<sup>[7]</sup> This allows for clear differentiation between primary and secondary N-methyl amines in this structural class.
- **Effect of Isomeric Position (ortho-, meta-, para-):** The primary fragmentation pathways, especially the dominant alpha-cleavage that generates the m/z 44 base peak, are independent of the bromine's position on the aromatic ring. While minor differences in the relative intensities of ring-containing fragments might occur due to subtle stability effects, the major m/z values will remain identical, making it difficult to distinguish between positional isomers by EI-MS alone without high-resolution mass spectrometry or reference standards.

## Experimental Protocol: GC-MS Analysis

Acquiring a high-quality mass spectrum is crucial for reliable identification. Gas Chromatography-Mass Spectrometry (GC-MS) with electron ionization is a standard method for analyzing volatile and semi-volatile compounds like the topic molecule.



[Click to download full resolution via product page](#)

Caption: General workflow for GC-MS analysis.

### Step-by-Step Methodology:

- **Sample Preparation:** Prepare a dilute solution of the sample (typically 0.1-1 mg/mL) in a volatile solvent compatible with the GC system, such as methanol or ethyl acetate.
- **GC Instrument Parameters (Typical):**
  - Injection Port: Split/splitless injector, set to 250 °C.
  - Carrier Gas: Helium, at a constant flow rate (e.g., 1 mL/min).
  - GC Column: A standard non-polar column, such as a 30 m x 0.25 mm DB-5ms or equivalent.
  - Oven Program: Start at 100 °C, hold for 1 minute, then ramp at 15 °C/min to 280 °C and hold for 5 minutes.
- **Mass Spectrometry Parameters (Typical for EI):**
  - Ionization Mode: Electron Ionization (EI).

- Electron Energy: 70 eV. This is a standard energy that promotes reproducible fragmentation and allows for comparison with library spectra.[8]
- Ion Source Temperature: 230 °C.
- Mass Analyzer: Quadrupole or Time-of-Flight (TOF).
- Scan Range: m/z 40-350 to ensure capture of the molecular ion and all significant fragments.
- Data Analysis:
  - Analyze the resulting total ion chromatogram (TIC) to identify the peak corresponding to the compound.
  - Extract the mass spectrum from this peak.
  - Identify the molecular ion peaks (m/z 229/231) and confirm the 1:1 isotopic ratio.
  - Identify the base peak (expected at m/z 44) and other major fragment ions.
  - Compare the acquired spectrum against a reference library like those from NIST or Wiley for confirmation.[9][10][11]

## Conclusion

The mass spectrometry fragmentation of **2-(2-Bromophenoxy)-N-methylethanamine** is highly predictable and informative. The fragmentation is dominated by a characteristic alpha-cleavage of the N-methylethanamine side chain, producing a stable iminium ion at m/z 44, which is typically the base peak. The presence of bromine provides a definitive isotopic signature in the molecular ion (m/z 229/231) and any fragments containing the aromatic ring (e.g., m/z 171/173). This detailed fragmentation pattern, when compared with structural analogues, allows for confident identification and differentiation from related compounds, making mass spectrometry an essential tool for its characterization.

## References

- Doc Brown's Chemistry. (n.d.). Mass spectrum of N-methylethanamine (ethylmethylanine). Retrieved from [[Link](#)]
- Gu, C., et al. (2014). Dependence of mass spectrometric fragmentation on the bromine substitution pattern of polybrominated diphenyl ethers. *Journal of Mass Spectrometry*, 49(6), 524-532. Retrieved from [[Link](#)]
- Al-Tannak, N. F., & Tose, L. V. (2018). Structural identification of compounds containing tertiary amine side chains using ESI-MS3 combined with fragmentation pattern matching to chemical analogues - Benzimidazole derivatives as a case study. *Rapid Communications in Mass Spectrometry*, 32(19), 1699-1710. Retrieved from [[Link](#)]
- Chemistry LibreTexts. (2023, August 29). Mass Spectrometry - Fragmentation Patterns. Retrieved from [[Link](#)]
- Lin, H.-Y., et al. (2018). Comparison of the Characteristic Mass Fragmentations of Phenethylamines and Tryptamines by Electron Ionization Gas Chromatography Mass Spectrometry, Electrospray and Matrix-Assisted Laser Desorption Ionization Mass Spectrometry. *Molecules*, 23(7), 1563. Retrieved from [[Link](#)]
- University of Arizona. (n.d.). Mass Spectrometry: Fragmentation. Retrieved from [[Link](#)]
- Wiley Science Solutions. (n.d.). Mass Spectral Databases. Retrieved from [[Link](#)]
- Wiley Science Solutions. (2023). Wiley Registry® / NIST Mass Spectral Library 2023. Retrieved from [[Link](#)]
- Diablo Analytical. (n.d.). NIST Mass Spectral Library. Retrieved from [[Link](#)]
- Chemistry LibreTexts. (2021, December 10). 1.7.4: Mass Spectrometry - Fragmentation Patterns. Retrieved from [[Link](#)]
- J-G-M-C. (2023, June 2). Fragmentation in Mass Spectrometry. Retrieved from [[Link](#)]
- Chemguide. (n.d.). Fragmentation patterns in the mass spectra of organic compounds. Retrieved from [[Link](#)]

- Doc Brown's Chemistry. (n.d.). Mass spectrum of 2-bromopropane. Retrieved from [[Link](#)]

### Need Custom Synthesis?

BenchChem offers custom synthesis for rare earth carbides and specific isotopic labeling.

Email: [info@benchchem.com](mailto:info@benchchem.com) or [Request Quote Online](#).

## Sources

- 1. [chemistry.miamioh.edu](http://chemistry.miamioh.edu) [[chemistry.miamioh.edu](http://chemistry.miamioh.edu)]
- 2. C<sub>3</sub>H<sub>7</sub>Br CH<sub>3</sub>CHBrCH<sub>3</sub> mass spectrum of 2-bromopropane fragmentation pattern of m/z m/e ions for analysis and identification of isopropyl bromide image diagram doc brown's advanced organic chemistry revision notes [[docbrown.info](http://docbrown.info)]
- 3. [youtube.com](http://youtube.com) [[youtube.com](http://youtube.com)]
- 4. [chemguide.co.uk](http://chemguide.co.uk) [[chemguide.co.uk](http://chemguide.co.uk)]
- 5. [chem.libretexts.org](http://chem.libretexts.org) [[chem.libretexts.org](http://chem.libretexts.org)]
- 6. [whitman.edu](http://whitman.edu) [[whitman.edu](http://whitman.edu)]
- 7. Comparison of the Characteristic Mass Fragmentations of Phenethylamines and Tryptamines by Electron Ionization Gas Chromatography Mass Spectrometry, Electrospray and Matrix-Assisted Laser Desorption Ionization Mass Spectrometry [[mdpi.com](http://mdpi.com)]
- 8. [pdf.benchchem.com](http://pdf.benchchem.com) [[pdf.benchchem.com](http://pdf.benchchem.com)]
- 9. Mass Spectral Databases - Wiley Science Solutions [[sciencesolutions.wiley.com](http://sciencesolutions.wiley.com)]
- 10. [agsanalitica.com](http://agsanalitica.com) [[agsanalitica.com](http://agsanalitica.com)]
- 11. [diabloanalytical.com](http://diabloanalytical.com) [[diabloanalytical.com](http://diabloanalytical.com)]
- To cite this document: BenchChem. [Mass spectrometry fragmentation pattern of 2-(2-Bromophenoxy)-N-methylethanamine]. BenchChem, [2026]. [Online PDF]. Available at: [<https://www.benchchem.com/product/b1341840/docs#mass-spectrometry-fragmentation-pattern-of-2-2-bromophenoxy-n-methylethanamine>]

---

### Disclaimer & Data Validity:

The information provided in this document is for Research Use Only (RUO) and is strictly not intended for diagnostic or therapeutic procedures. While BenchChem strives to provide

accurate protocols, we make no warranties, express or implied, regarding the fitness of this product for every specific experimental setup.

**Technical Support:** The protocols provided are for reference purposes. Unsure if this reagent suits your experiment?

**Need Industrial/Bulk Grade?** [Request Custom Synthesis Quote](#)

## BenchChem

Our mission is to be the trusted global source of essential and advanced chemicals, empowering scientists and researchers to drive progress in science and industry.

### Contact

Address: 3281 E Guasti Rd

Ontario, CA 91761, United States

Phone: (601) 213-4426

Email: [info@benchchem.com](mailto:info@benchchem.com)

[Contact our Ph.D. Support Team for a compatibility check](#)