

# leico-4F: A Technical Guide for Advanced Photovoltaic Research

**Author:** BenchChem Technical Support Team. **Date:** April 2026

## Compound of Interest

Compound Name: *leico-4F*  
Cat. No.: *B13400239*

[Get Quote](#)

An In-depth Technical Guide for Researchers, Scientists, and Drug Development Professionals

## Abstract

**leico-4F** is a prominent non-fullerene acceptor (NFA) that has garnered significant attention within the organic electronics community. Its unique chemical structure, characterized by an A-D-A (Acceptor-Donor-Acceptor) configuration, imparts favorable optoelectronic properties, making it a crucial component in high-performance organic solar cells (OSCs) and organic photodetectors (OPDs). This guide provides a comprehensive overview of **leico-4F**, detailing its mechanism of action within photovoltaic devices, summarizing key performance data, and outlining standardized experimental protocols for its application and characterization. The information presented herein is intended to serve as a valuable resource for researchers and professionals engaged in the development of next-generation organic electronic devices.

## Introduction to leico-4F

**leico-4F**, with the CAS number 2089044-02-8, is a small molecule NFA possessing a low band-gap and exhibiting low energy loss in photovoltaic devices.<sup>[1]</sup> Its structure features an electron-donating indaceno[1,2-b:5,6-b']dithiophene (IDT) core flanked by two electron-withdrawing 2-(5,6-difluoro-3-oxo-2,3-dihydro-1H-inden-1-ylidene)malononitrile (IC-2F) units, with thiophene

spacers.[1] This molecular design leads to strong light absorption in the near-infrared (NIR) region, with a maximum absorption around 860 nm, which is a significant red-shift compared to other NFAs like ITIC.[1] This broad absorption profile makes **leico-4F** particularly effective in harvesting a larger portion of the solar spectrum, thereby enhancing the efficiency of organic solar cells.

## Mechanism of Action in Organic Solar Cells

The primary role of **leico-4F** in an organic solar cell is to facilitate the conversion of light into electrical current. This process can be broken down into several key steps, as illustrated in the energy level diagram and charge generation pathway below. In a typical bulk heterojunction (BHJ) solar cell, **leico-4F** is blended with an electron donor material, such as the polymer PTB7-Th.

- **Light Absorption and Exciton Generation:** When photons from sunlight strike the active layer of the solar cell, they are absorbed by both the donor (e.g., PTB7-Th) and the acceptor (**leico-4F**) materials. This absorption of energy excites an electron from the Highest Occupied Molecular Orbital (HOMO) to the Lowest Unoccupied Molecular Orbital (LUMO), creating a tightly bound electron-hole pair known as an exciton.
- **Exciton Diffusion:** The newly formed excitons diffuse through the donor or acceptor domains until they reach the interface between the two materials.
- **Charge Separation (Dissociation):** At the donor-acceptor interface, the energy difference between the LUMO levels of the donor and acceptor materials provides the driving force for the exciton to dissociate. The electron is transferred from the donor's LUMO to the acceptor's (**leico-4F**) LUMO, while the hole remains in the donor's HOMO. This charge separation is a critical step in generating free charge carriers.
- **Charge Transport:** Once separated, the free electrons travel through the interconnected network of the **leico-4F** acceptor domains towards the electron-collecting electrode (cathode). Simultaneously, the holes move through the donor polymer domains towards the hole-collecting electrode (anode).
- **Charge Collection:** The electrons and holes are collected at their respective electrodes, generating a photocurrent and completing the photovoltaic circuit.

The efficiency of this entire process is highly dependent on the energetic alignment of the donor and acceptor materials, as well as the morphology of the blend film.

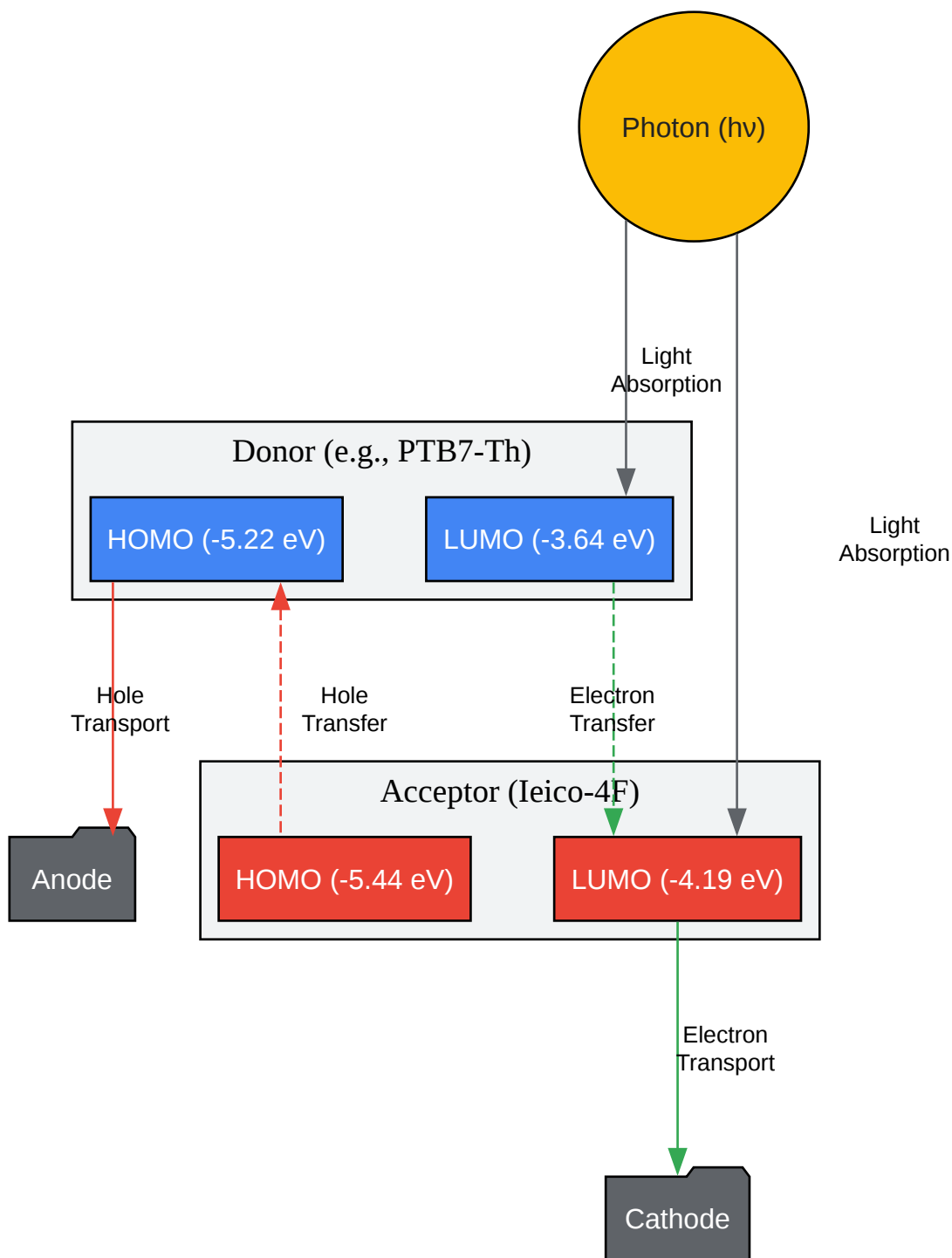

[Click to download full resolution via product page](#)

**Caption:** Energy level diagram of a PTB7-Th:leico-4F organic solar cell.

## Quantitative Data Summary

The performance of organic solar cells incorporating **leico-4F** is highly dependent on the choice of donor material, blend ratio, and fabrication conditions. The following tables summarize key photovoltaic parameters and charge transport properties reported for **leico-4F**-based devices.

Table 1: Photovoltaic Performance of **leico-4F** Based Organic Solar Cells

Donor Material	Device Architecture	Open-Circuit Voltage (VOC) [V]	Short-Circuit Current Density (JSC) [mA/cm <sup>2</sup> ]	Fill Factor (FF) [%]	Power Conversion Efficiency (PCE) [%]
PTB7-Th	ITO/ZnO/PTB7-Th:leico-4F/MoOx/Ag	0.71	27.3	66	12.8
PTB7-Th (ternary with BIT-4F-T)	ITO/ZnO/PTB7-Th:BIT-4F-T:leico-4F/MoOx/Ag	-	-	-	14.0[1]
PTB7-Th (ternary with PC71BM)	ITO/ZnO/PTB7-Th:PC71BM:leico-4F/MoOx/Ag	-	-	-	9.8[2]
P3HT (ternary with PC71BM)	-	-	-	-	-

Note: Data is compiled from various sources and represents optimized device performance. "-" indicates data not available in the cited sources.

Table 2: Charge Transport Properties of **leico-4F**

Property	Value	Measurement Technique
Electron Mobility ( $\mu\text{e}$ )	$8.1 \times 10^{-4} \text{ cm}^2\text{V}^{-1}\text{s}^{-1}$	Space-Charge-Limited Current (SCLC)
Hole Mobility ( $\mu\text{h}$ )	-	-

Note: Mobility values can vary depending on the film processing and measurement conditions.

## Experimental Protocols

This section provides a detailed methodology for the fabrication and characterization of a standard inverted organic solar cell using a PTB7-Th:**leico-4F** active layer.

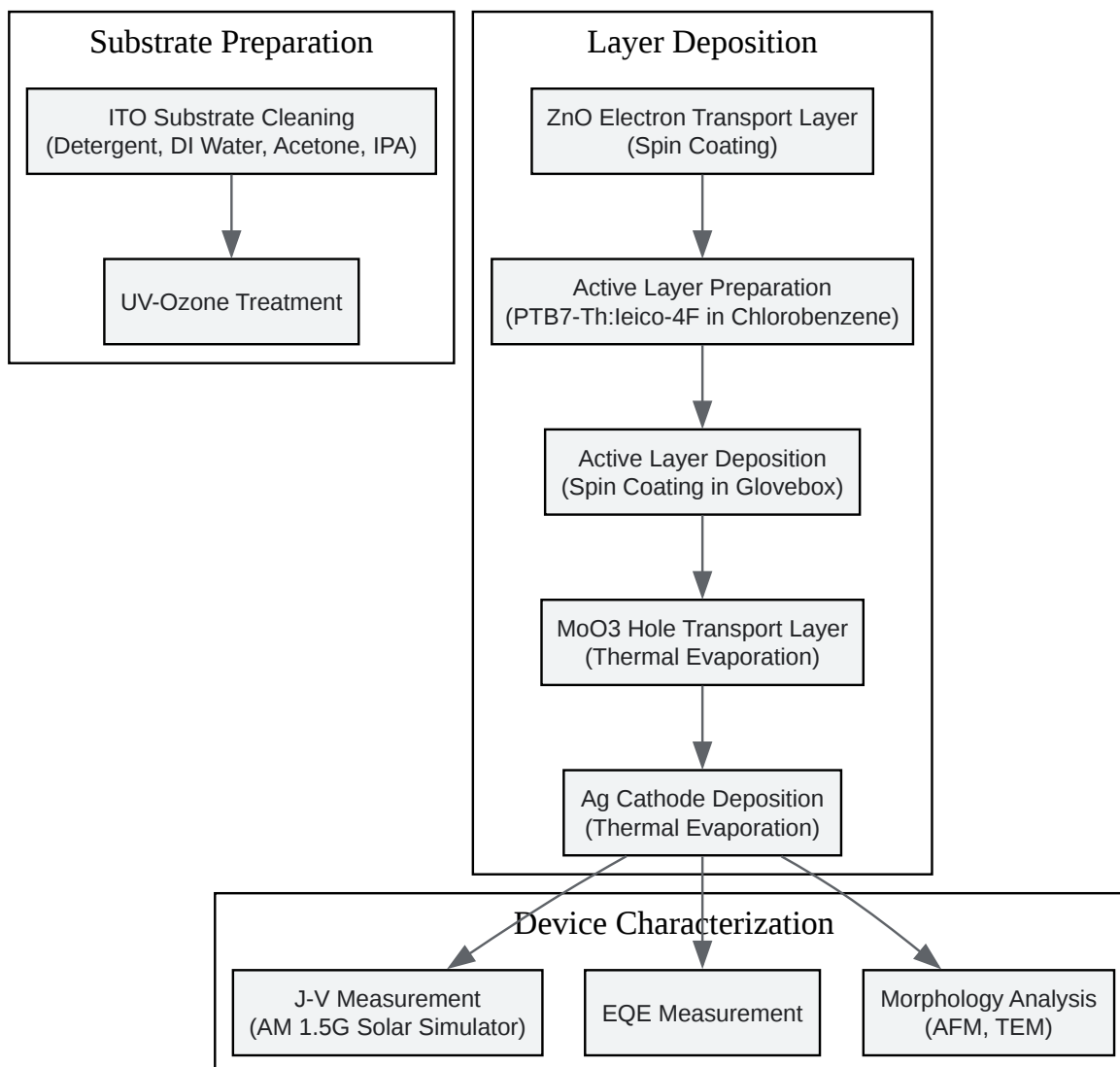

[Click to download full resolution via product page](#)

**Caption:** Experimental workflow for **leico-4F** based organic solar cell fabrication.

## Materials and Reagents

- Substrate: Indium Tin Oxide (ITO) coated glass
- Electron Transport Layer (ETL): Zinc Oxide (ZnO) nanoparticle solution

- Donor Polymer: PTB7-Th (Poly[[4,8-bis[(2-ethylhexyl)oxy]benzo[1,2-b:4,5-b']dithiophene-2,6-diyl][3-fluoro-2-[(2-ethylhexyl)carbonyl]thieno[3,4-b]thiophenediyl]])
- Acceptor: **leico-4F**
- Hole Transport Layer (HTL): Molybdenum(VI) oxide (MoO<sub>3</sub>)
- Cathode: Silver (Ag)
- Solvent: Chlorobenzene (CB)
- Cleaning Solvents: Deionized water, acetone, isopropanol (IPA)

## Device Fabrication Procedure

- ITO Substrate Cleaning:
  - The ITO-coated glass substrates are sequentially cleaned in an ultrasonic bath with detergent, deionized water, acetone, and isopropanol for 15 minutes each.
  - The cleaned substrates are then dried with a nitrogen gun.
  - Finally, the substrates are treated with UV-ozone for 15 minutes to improve the surface wettability and work function.
- ZnO Electron Transport Layer Deposition:
  - A solution of ZnO nanoparticles is spin-coated onto the cleaned ITO substrates.
  - The substrates are then annealed at a specified temperature (e.g., 200°C) for a certain duration (e.g., 30 minutes) to form a uniform ZnO layer.<sup>[2]</sup>
- Active Layer Preparation and Deposition:
  - A blend solution of PTB7-Th and **leico-4F** is prepared in chlorobenzene at a specific concentration (e.g., 20 mg/mL) and donor:acceptor ratio (e.g., 1:1.5 by weight).
  - The solution is typically stirred overnight at an elevated temperature to ensure complete dissolution.

- The active layer solution is then spin-coated onto the ZnO layer inside a nitrogen-filled glovebox to prevent degradation from oxygen and moisture. The spin speed and time are optimized to achieve the desired film thickness (e.g., 100 nm).[2]
- MoO<sub>3</sub> Hole Transport Layer and Ag Cathode Deposition:
  - A thin layer of MoO<sub>3</sub> (e.g., 5-10 nm) is deposited on top of the active layer by thermal evaporation under high vacuum.
  - Subsequently, a thicker layer of Ag (e.g., 100 nm) is deposited as the top electrode, also via thermal evaporation.

## Device Characterization

- Current Density-Voltage (J-V) Characteristics: The photovoltaic performance of the fabricated devices is measured under simulated AM 1.5G solar illumination (100 mW/cm<sup>2</sup>) using a solar simulator. Key parameters such as VOC, JSC, FF, and PCE are extracted from the J-V curves.
- External Quantum Efficiency (EQE): EQE measurements are performed to determine the ratio of collected charge carriers to incident photons at various wavelengths. This provides insights into the spectral response of the solar cell and helps to verify the measured JSC.
- Charge Carrier Mobility: The electron and hole mobilities of the active layer blend are typically measured using the space-charge-limited current (SCLC) method with dedicated single-carrier devices.
- Morphology Characterization: The morphology of the PTB7-Th:**leico-4F** blend film is investigated using techniques such as Atomic Force Microscopy (AFM) and Transmission Electron Microscopy (TEM) to understand the phase separation and domain sizes, which are crucial for efficient charge transport.

## Conclusion

**leico-4F** stands out as a highly promising non-fullerene acceptor for organic photovoltaics due to its strong near-infrared absorption and favorable electronic properties. The mechanism of action within a solar cell relies on the efficient generation, separation, and transport of charge

carriers at the interface with a suitable donor material. By carefully optimizing the device architecture, blend morphology, and fabrication protocols, **leico-4F** has been instrumental in achieving high power conversion efficiencies. The data and experimental guidelines presented in this technical guide offer a solid foundation for researchers to further explore and enhance the potential of **leico-4F** in advanced organic electronic applications.

#### *Need Custom Synthesis?*

*BenchChem offers custom synthesis for rare earth carbides and specific isotopic labeling.*

*Email: [info@benchchem.com](mailto:info@benchchem.com) or [Request Quote Online](#).*

## References

- [1. ossila.com](https://ossila.com) [[ossila.com](https://ossila.com)]
- [2. researchgate.net](https://researchgate.net) [[researchgate.net](https://researchgate.net)]
- To cite this document: BenchChem. [leico-4F: A Technical Guide for Advanced Photovoltaic Research]. BenchChem, [2026]. [Online PDF]. Available at: [<https://www.benchchem.com/product/b13400239/docs#leico-4f-a-technical-guide-for-advanced-photovoltaic-research>]

---

#### **Disclaimer & Data Validity:**

The information provided in this document is for Research Use Only (RUO) and is strictly not intended for diagnostic or therapeutic procedures. While BenchChem strives to provide accurate protocols, we make no warranties, express or implied, regarding the fitness of this product for every specific experimental setup.

**Technical Support:** The protocols provided are for reference purposes. Unsure if this reagent suits your experiment?

**Need Industrial/Bulk Grade?** [Request Custom Synthesis Quote](#)

# BenchChem

Our mission is to be the trusted global source of essential and advanced chemicals, empowering scientists and researchers to drive progress in science and industry.

## Contact

Address: 3281 E Guasti Rd

Ontario, CA 91761, United States

Phone: (601) 213-4426

Email: [info@benchchem.com](mailto:info@benchchem.com)

[Contact our Ph.D. Support Team for a compatibility check](#)