

Comparative Technical Analysis: Benzyl Azide vs. (2-Azidoethoxy)benzene in High-Fidelity Bioconjugation

Author: BenchChem Technical Support Team. **Date:** May 2026

Compound of Interest

Compound Name: (2-Azidoethoxy)benzene

CAS No.: 70659-90-4

Cat. No.: B1340148

[Get Quote](#)

Executive Summary

This technical guide analyzes the structural, kinetic, and safety distinctions between Benzyl Azide (BnN

) and **(2-Azidoethoxy)benzene** (Ph-O-Et-N

). While both serve as fundamental aryl-linked azide precursors in Click Chemistry (CuAAC), their divergent physicochemical profiles dictate their suitability for specific applications. Benzyl azide offers a rigid, hyper-conjugated linker often used as a kinetic standard, whereas **(2-azidoethoxy)benzene** provides a flexible, hydrophilic tether capable of secondary coordination effects. This guide provides actionable protocols for their synthesis, purification, and safe handling, grounded in physical organic chemistry.

Structural & Electronic Architecture

The core difference between these two molecules lies in the linker composition, which governs both their electronic reactivity and their hydrodynamic properties.

Benzyl Azide (Hard Linker)[1]

- Structure: Phenyl ring directly attached to a methylene () spacer holding the azide.
- Electronic Effect: The benzylic position allows for hyperconjugation. The transition state during cycloaddition is stabilized by the aromatic ring's ability to delocalize developing charge, making BnN a highly reactive "standard" in CuAAC.
- Hydrophobicity: High. The methylene linker adds no polarity, resulting in poor aqueous solubility without co-solvents.

(2-Azidoethoxy)benzene (Soft Linker)

- Structure: Phenyl ring attached to an ethylene glycol-like spacer (-O-CH-CH-).
-CH-
-).
- Electronic Effect: The oxygen atom exerts a negative inductive effect (-I) on the alkyl chain, slightly deactivating the azide nucleophilicity compared to an alkyl azide. However, the oxygen atom acts as a Lewis base. In Cu(I)-catalyzed reactions, this oxygen can transiently coordinate with the copper center, potentially accelerating the reaction via anchimeric assistance (chelation-controlled catalysis).
- Flexibility: The ether linkage introduces rotational freedom, reducing steric strain in bioconjugation events.

Synthetic Pathways & Validation Protocols

Visualization of Synthetic Workflows

The following diagram contrasts the direct substitution route of Benzyl Azide with the two-step etherification-substitution route for **(2-Azidoethoxy)benzene**.

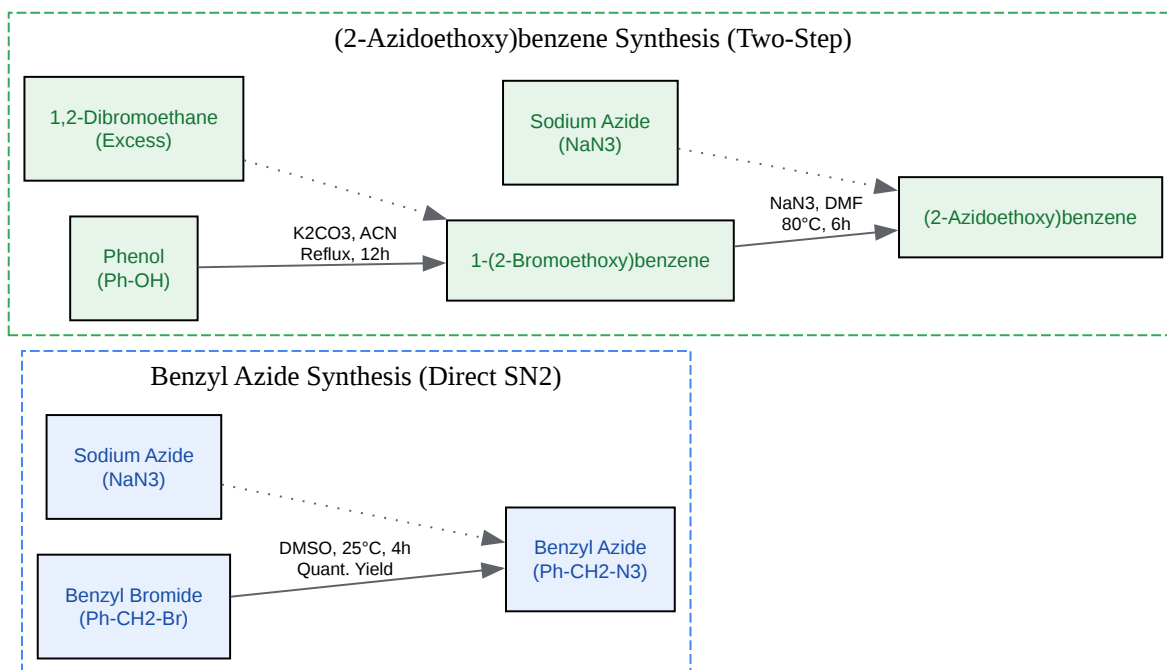

[Click to download full resolution via product page](#)

Caption: Comparative synthetic workflows. Path A (Blue) utilizes direct nucleophilic substitution. Path B (Green) requires Williamson ether synthesis followed by azidation.

Detailed Protocols

Protocol A: Benzyl Azide (Standard)[1]

- Reagents: Benzyl bromide (1.0 eq), Sodium azide (1.2 eq), DMSO (0.5 M).
- Procedure:
 - Dissolve NaN
 - in DMSO (highly exothermic solvation; allow to cool).
 - Add Benzyl bromide dropwise at 0°C to prevent thermal runaway.

- Stir at RT for 4 hours.
- Workup: Dilute with H₂O, extract with Et₂O. Wash organic layer 3x with H₂O to remove DMSO. Dry over MgSO₄.
- Validation: IR peak at ~2100 cm⁻¹ (Azide stretch).
H NMR: Singlet at 4.35 ppm (CH₂).

Protocol B: (2-Azidoethoxy)benzene (Ether Linker)

- Step 1 (Etherification): Phenol (1.0 eq) + 1,2-Dibromoethane (3.0 eq) + K₂CO₃ in Acetonitrile (Reflux). Note: Excess dibromoethane prevents dimerization.
- Step 2 (Azidation): Crude bromoether + NaN₃ (1.5 eq) in DMF at 80°C.
- Validation:
H NMR shows two triplets:
4.15 (O-CH₂) and 3.60 (N₂CH₂).

-CH

). The upfield shift of the CH

adjacent to the azide (relative to oxygen) confirms substitution.

Reactivity Profiling: The "Oxygen Effect" in CuAAC

In Copper-Catalyzed Azide-Alkyne Cycloaddition (CuAAC), the reaction rate is often governed by the ability of the azide to coordinate with the Cu(I)-acetylide complex.

Chelation-Assisted Mechanism

Unlike Benzyl Azide, **(2-azidoethoxy)benzene** possesses a Lewis-basic ether oxygen. In non-coordinating solvents (e.g., Toluene, DCM), this oxygen can stabilize the Cu(I) intermediate, effectively increasing the local concentration of the catalyst near the reactive center.

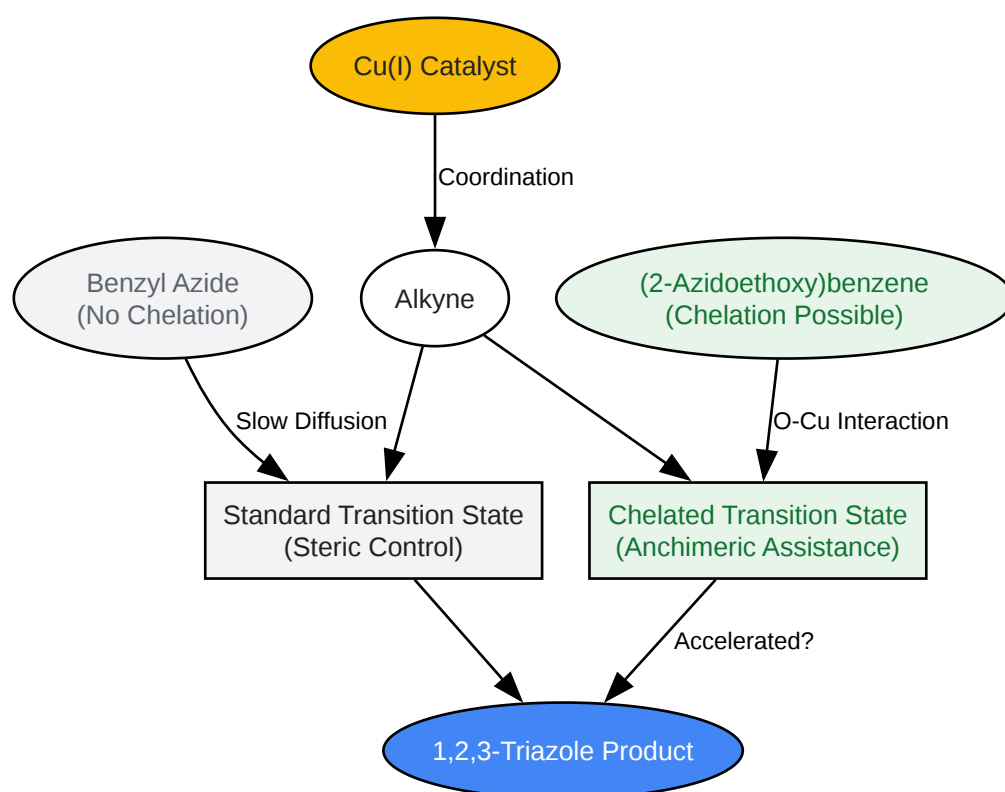

[Click to download full resolution via product page](#)

Caption: Mechanistic divergence. The ether oxygen in **(2-azidoethoxy)benzene** can stabilize the Cu-intermediate (Green Path), potentially altering kinetics compared to the steric-only

Benzyl Azide path.

Safety & Handling Protocols

Safety in organic azide chemistry is dictated by the Carbon-to-Nitrogen (C/N) Ratio.^[2] The general rule of thumb for safe isolation is

Comparative Safety Metrics

Metric	Benzyl Azide	(2-Azidoethoxy)benzene
Formula	C	C
	H	H
	N	N
		O
Molecular Weight	133.15 g/mol	163.18 g/mol
C/N Ratio	$7 / 3 = 2.33$	$(8 + 1) / 3 = 3.0$
Classification	High Hazard	Moderate Hazard
Volatility	Volatile Oil	Low Volatility Oil
Thermal Stability	Decomposes >180°C	Stable >200°C

Critical Handling Rules

- Benzyl Azide:
 - NEVER distill to dryness.
 - NEVER use rotary evaporation bath >40°C.
 - Store as a solution (e.g., 0.5 M in Toluene) whenever possible to mitigate shock sensitivity.
 - Risk:^[3]^[4]^[5] Low C/N ratio places it on the borderline of explosive potential.

- **(2-Azidoethoxy)benzene:**
 - Meets the "Rule of 3" (Ratio = 3.0).
 - Can be handled safely as a neat oil in small quantities (<5g).
 - Preferred for scale-up due to higher molecular weight and lower vapor pressure.

Application Case Studies

Case 1: Fragment-Based Drug Discovery (FBDD)

- Choice: Benzyl Azide. [\[2\]](#)[\[6\]](#)[\[5\]](#)[\[7\]](#)[\[8\]](#)[\[9\]](#)[\[10\]](#)
- Reasoning: When screening small aromatic fragments, the benzyl linker is minimal. It does not introduce polar surface area (PSA) that might artificially improve solubility, giving a "truer" read of the fragment's binding affinity.

Case 2: PROTAC Linker Design

- Choice: **(2-Azidoethoxy)benzene**.
- Reasoning: PROTACs require flexible linkers to allow the E3 ligase and target protein to adopt a productive ternary complex. The ether oxygen improves water solubility (critical for large PROTAC molecules) and the ethylene spacer provides the necessary "flop" that a rigid benzyl group lacks.

References

- Reactivity of Benzyl Azide: R. Huisgen, 1,3-Dipolar Cycloadditions. Past and Future, *Angew. Chem. Int. Ed.*, 1963, 2, 565.
- Safety of Organic Azides: Bräse, S., et al., Organic Azides: An Exploding Diversity of a Unique Class of Compounds, *Angew. Chem. Int. Ed.*, 2005, 44, 5188.
- CuAAC Mechanism & Chelation: Meldal, M., & Tornøe, C. W., Cu-Catalyzed Azide–Alkyne Cycloaddition, *Chem. Rev.*, 2008, 108, 2952.

- Synthesis of Phenoxyethyl Azides: Organic Syntheses, Coll. Vol. 10, p.207 (2004). (General protocol adaptation).
- Benzyl Azide Safety Data: PubChem Compound Summary for CID 12152.

Need Custom Synthesis?

BenchChem offers custom synthesis for rare earth carbides and specific isotopic labeling.

Email: info@benchchem.com or [Request Quote Online](#).

Sources

- [1. beilstein-archives.org \[beilstein-archives.org\]](https://beilstein-archives.org)
- [2. pdf.benchchem.com \[pdf.benchchem.com\]](https://pdf.benchchem.com)
- [3. Benzyl azide | C7H7N3 | CID 12152 - PubChem \[pubchem.ncbi.nlm.nih.gov\]](https://pubchem.ncbi.nlm.nih.gov)
- [4. beilstein-journals.org \[beilstein-journals.org\]](https://beilstein-journals.org)
- [5. BJOC - Azide–alkyne cycloaddition \(click\) reaction in biomass-derived solvent Cyrene™ under one-pot conditions \[beilstein-journals.org\]](https://beilstein-journals.org)
- [6. BENZYL AZIDE | 622-79-7 \[chemicalbook.com\]](https://chemicalbook.com)
- [7. fishersci.com \[fishersci.com\]](https://fishersci.com)
- [8. Benzyl azide 0.5M dichloromethane, = 95.0 HPLC 622-79-7 \[sigmaaldrich.com\]](https://sigmaaldrich.com)
- [9. On the Question of Zwitterionic Intermediates in the \[3+2\] Cycloaddition Reactions between Aryl Azides and Ethyl Propiolate - PMC \[pmc.ncbi.nlm.nih.gov\]](https://pmc.ncbi.nlm.nih.gov)
- [10. researchgate.net \[researchgate.net\]](https://researchgate.net)
- To cite this document: BenchChem. [Comparative Technical Analysis: Benzyl Azide vs. (2-Azidoethoxy)benzene in High-Fidelity Bioconjugation]. BenchChem, [2026]. [Online PDF]. Available at: [<https://www.benchchem.com/product/b1340148/docs#comparative-technical-analysis-benzyl-azide-vs-2-azidoethoxy-benzene-in-high-fidelity-bioconjugation>]

Disclaimer & Data Validity:

The information provided in this document is for Research Use Only (RUO) and is strictly not intended for diagnostic or therapeutic procedures. While BenchChem strives to provide

accurate protocols, we make no warranties, express or implied, regarding the fitness of this product for every specific experimental setup.

Technical Support: The protocols provided are for reference purposes. Unsure if this reagent suits your experiment?

Need Industrial/Bulk Grade? [Request Custom Synthesis Quote](#)

BenchChem

Our mission is to be the trusted global source of essential and advanced chemicals, empowering scientists and researchers to drive progress in science and industry.

Contact

Address: 3281 E Guasti Rd

Ontario, CA 91761, United States

Phone: (601) 213-4426

Email: info@benchchem.com

[Contact our Ph.D. Support Team for a compatibility check](#)