

Comparative Guide: Dielectric Performance of Phthalonitrile Resins in High-Frequency Electronics

Author: BenchChem Technical Support Team. **Date:** April 2026

Compound of Interest

Compound Name: 4,5-Di(3-pyridinyloxy)phthalonitrile

CAS No.: 147699-68-1

Cat. No.: B134272

[Get Quote](#)

Executive Summary

As 5G and 6G telecommunication standards push operating frequencies into the millimeter-wave (mmWave) spectrum (30–300 GHz), the demand for materials with ultra-low dielectric constant (

) and dissipation factor (

) has intensified. Traditional thermosets like epoxy and polyimide often fail to balance these dielectric requirements with the extreme thermal stability needed for aerospace and advanced semiconductor packaging.

Phthalonitrile (PN) resins have emerged as a superior alternative, offering a unique combination of glass transition temperatures (

) exceeding 400°C and tunable dielectric properties.[1] This guide provides an objective, data-driven comparison of PN resins against standard alternatives, detailing the mechanistic drivers

of their performance and providing validated experimental protocols for synthesis and characterization.

Comparative Landscape: Phthalonitrile vs. Alternatives

The following matrix compares standard Phthalonitrile resins against high-performance competitors. Note that while Cyanate Esters are the current gold standard for low loss, modified PN resins offer superior thermal survivability.

Table 1: Performance Matrix of High-Temperature Thermosets

Property	Phthalonitrile (Standard)	Fluorinated Phthalonitrile	High-Temp Epoxy	Polyimide (PI)	Cyanate Ester (CE)
Dielectric Constant (@ 10 GHz)	3.0 – 3.5	2.4 – 2.8	3.5 – 4.0	3.1 – 3.4	2.6 – 2.9
Dissipation Factor (@ 10 GHz)	0.01 – 0.02	0.002 – 0.007	0.015 – 0.03	0.005 – 0.01	0.003 – 0.006
Glass Transition ()	> 400°C	> 400°C	150 – 220°C	250 – 350°C	250 – 290°C
Water Absorption	< 1.5%	< 0.8%	1.0 – 3.0%	1.5 – 3.0%	< 1.0%
Processing Window	Wide (Melt stable)	Excellent	Narrow	Solvent-heavy	Sensitive to moisture
Primary Limitation	Brittleness	Cost	Low Thermal Stability	High / Water uptake	Hydrolytic instability

Analyst Insight: While Cyanate Esters offer excellent native dielectric properties, they degrade rapidly above 300°C. Fluorinated Phthalonitriles (e.g., PBDP) bridge this gap, matching CE's dielectric performance while maintaining the extreme thermal resistance characteristic of the PN class.

Mechanistic Analysis: Engineering Low Dielectric Loss

To optimize PN resins for electronics, researchers must manipulate the polymer network to minimize dipolar polarization.

Structural Modification Strategies

- **Fluorination:** Introducing C–F bonds (e.g., using decafluorobiphenyl backbones) reduces electronic polarizability due to the small atomic radius and high electronegativity of fluorine. This also increases free volume, further lowering dielectric loss.
- **Porosity Introduction:** Incorporating Hollow Glass Microspheres (HGM) or creating nanoporous structures introduces air () into the matrix.
- **Crosslink Density Control:** A highly crosslinked network restricts the physical movement of dipoles, reducing orientational polarization at lower frequencies.

Curing Mechanism & Network Formation

The dielectric performance is heavily influenced by the curing degree. Incomplete curing leaves residual polar nitrile groups (-CN), which increase dielectric loss.

. A complete cure transforms these into stable, non-polar heterocyclic rings (triazine, phthalocyanine, isoindoline).

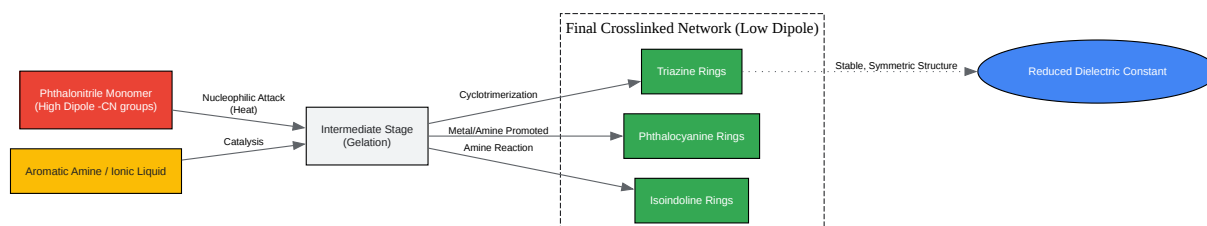

[Click to download full resolution via product page](#)

Figure 1: Transformation of polar nitrile monomers into stable, low-polarity heterocyclic networks during curing.

Experimental Protocols

Synthesis of Fluorinated Phthalonitrile (PBDP)

Objective: Synthesize a low-melting, fluorinated PN resin to minimize dielectric loss.

Reagents:

- Bisphenol A (BPA)
- Decafluorobiphenyl (DFBP)
- 4-Nitrophthalonitrile[2][3]
- Potassium Carbonate ()

- Solvent: N,N-Dimethylformamide (DMF) or DMAc

Protocol:

- Nucleophilic Substitution (Step 1): Dissolve BPA and DFBP in DMF. Add
. Heat to 60°C for 4 hours to form the fluorinated precursor.
- End-Capping (Step 2): Add 4-nitrophthalonitrile to the reaction mixture. Raise temperature to 80-100°C for 6-8 hours.
- Precipitation: Pour the cooled mixture into dilute HCl/water solution to precipitate the crude resin.
- Purification: Wash repeatedly with hot water and ethanol to remove residual salts and solvents. Dry in a vacuum oven at 80°C for 12 hours.
- Validation: Confirm structure via FTIR (Look for -CN peak at ~2230
and C-F peaks at 1000-1350
).

Dielectric Measurement (Waveguide Method)

Objective: Accurately measure

and

in the Q-band (30–50 GHz).

Equipment:

- Vector Network Analyzer (VNA) (e.g., Anritsu or Keysight)
- WR-22 or WR-28 Waveguide fixtures
- Thru-Reflect-Line (TRL) Calibration Kit

Workflow:

- Sample Prep: Machine the cured resin into a rectangular block exactly matching the waveguide inner dimensions (e.g., 7.112 mm x 3.556 mm for WR-28). Critical: Air gaps introduce significant error.
- Calibration: Perform TRL calibration to remove cable and fixture errors.
- S-Parameter Extraction: Insert sample. Measure
(Reflection) and
(Transmission).
- Nicholson-Ross-Weir (NRW) Conversion: Use the NRW algorithm to convert complex S-parameters into complex permittivity (

).

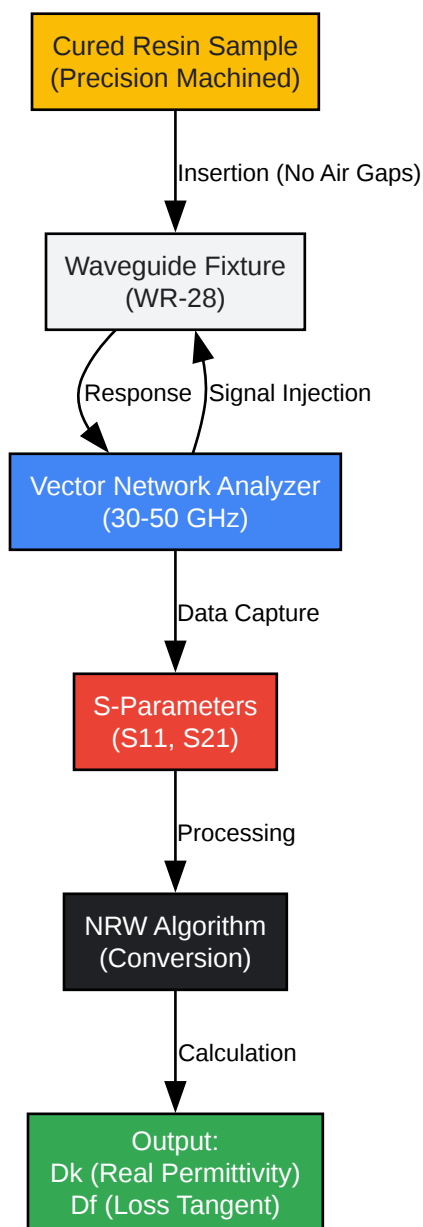

[Click to download full resolution via product page](#)

Figure 2: High-frequency dielectric characterization workflow using VNA and Waveguide.

Data Analysis: Quantitative Performance

The following data aggregates recent findings on modified PN resins compared to a control.

Table 2: Dielectric Properties of Modified Phthalonitrile Systems

Material System	Frequency	Dielectric Constant ()	Dissipation Factor ()	Reference
Pure PBDP (Fluorinated PN)	12 GHz	2.43	0.007	[1]
PBDP + 27.5% HGM (Microspheres)	12 GHz	1.85	0.004	[1]
Epoxy-PN Blend (50:50)	10 MHz	2.01	0.011	[2]
Standard PN (Control)	1 MHz	3.05	0.018	[3]
PN-Bismaleimide Copolymer	1 MHz	3.29	0.009	[4]

Key Takeaway: The introduction of Hollow Glass Microspheres (HGM) into a fluorinated PN matrix (PBDP) results in a composite with a

approaching 1.85, competing directly with PTFE but offering vastly superior thermal stability ().

References

- Rational Design of Fluorinated Phthalonitrile/Hollow Glass Microsphere Composite. MDPI. (2022).
- Preparation of fluorinated epoxy-phthalonitrile resins with excellent thermal stability and low dielectric constant. Journal of Applied Polymer Science. (2023).
- A high-performance functional phthalonitrile resin with a low melting point and a low dielectric constant. Soft Matter (RSC). (2020). [1]

- Advanced Design and Fabrication of High-Strength Phthalonitrile Thermosets With Low Dielectric Constants. *Journal of Applied Polymer Science*. (2018).
- Dielectric properties of the composite laminates. *ResearchGate*. (2019).

Need Custom Synthesis?

BenchChem offers custom synthesis for rare earth carbides and specific isotopic labeling.

Email: info@benchchem.com or [Request Quote Online](#).

Sources

- [1. papers.ssrn.com](https://papers.ssrn.com) [papers.ssrn.com]
- [2. tohoku.elsevierpure.com](https://tohoku.elsevierpure.com) [tohoku.elsevierpure.com]
- [3. A high-performance functional phthalonitrile resin with a low melting point and a low dielectric constant - Soft Matter \(RSC Publishing\)](https://pubs.rsc.org) [pubs.rsc.org]
- To cite this document: BenchChem. [Comparative Guide: Dielectric Performance of Phthalonitrile Resins in High-Frequency Electronics]. BenchChem, [2026]. [Online PDF]. Available at: [<https://www.benchchem.com/product/b134272/docs#comparative-guide-dielectric-performance-of-phthalonitrile-resins-in-high-frequency-electronics>]

Disclaimer & Data Validity:

The information provided in this document is for Research Use Only (RUO) and is strictly not intended for diagnostic or therapeutic procedures. While BenchChem strives to provide accurate protocols, we make no warranties, express or implied, regarding the fitness of this product for every specific experimental setup.

Technical Support: The protocols provided are for reference purposes. Unsure if this reagent suits your experiment?

Need Industrial/Bulk Grade? [Request Custom Synthesis Quote](#)

BenchChem

Our mission is to be the trusted global source of essential and advanced chemicals, empowering scientists and researchers to drive progress in science and industry.

Contact

Address: 3281 E Guasti Rd

Ontario, CA 91761, United States

Phone: (601) 213-4426

Email: info@benchchem.com

[Contact our Ph.D. Support Team for a compatibility check](#)