

Application Note & Protocols: Investigating Cell Proliferation with Adenosine 5'-monophosphate (AMP)

Author: BenchChem Technical Support Team. **Date:** April 2026

Compound of Interest

Compound Name: Adenosine5'-
monophosphatesodiumsalt

Cat. No.: B13397499

[Get Quote](#)

Abstract

Adenosine 5'-monophosphate (AMP) is a central molecule in cellular bioenergetics and signaling. While traditionally viewed as an intracellular energy sensor, extracellular AMP also exerts significant effects on cell fate, including proliferation. This document provides a comprehensive guide for researchers, scientists, and drug development professionals on designing and executing studies to investigate the impact of Adenosine 5'-monophosphate sodium salt on cell proliferation. We delve into the key signaling pathways, provide detailed, validated protocols for essential in vitro assays, and offer insights into data interpretation.

Introduction: The Dual Role of AMP in Cellular Growth

Adenosine 5'-monophosphate is a critical nucleotide present both inside and outside the cell. Intracellularly, the ratio of AMP/ATP is a key indicator of the cell's energy status. A rise in this ratio activates AMP-activated protein kinase (AMPK), a master regulator of metabolism that

generally shifts cells from anabolic (growth) to catabolic (energy-producing) states, often leading to an inhibition of proliferation.[1][2]

Extracellularly, AMP's role is more complex. It can be converted to adenosine by ecto-5'-nucleotidase (CD73), an enzyme often found on the cell surface.[3][4][5][6] Adenosine then acts on various adenosine receptors (A1, A2A, A2B, A3), which can have either pro-proliferative or anti-proliferative effects depending on the receptor subtype and cell type.[7][8][9] Therefore, the effect of exogenously applied AMP on cell proliferation can be multifaceted, involving direct activation of intracellular pathways or indirect effects through its conversion to adenosine.[10] Understanding these distinct mechanisms is crucial for designing and interpreting experiments.

Key Signaling Pathways

The AMPK Energy-Sensing Pathway

When cellular energy levels are low, as indicated by a high AMP:ATP ratio, AMPK is activated.[1][2] Activated AMPK then phosphorylates numerous downstream targets to restore energy homeostasis. A key consequence of AMPK activation is the inhibition of the mammalian target of rapamycin complex 1 (mTORC1) pathway, a central regulator of cell growth and proliferation.[1][11] This inhibition occurs through the phosphorylation of TSC2 and Raptor, components of the mTORC1 complex.[12] AMPK activation can also lead to cell cycle arrest, providing a direct link to the control of cell proliferation.[11][13][14]

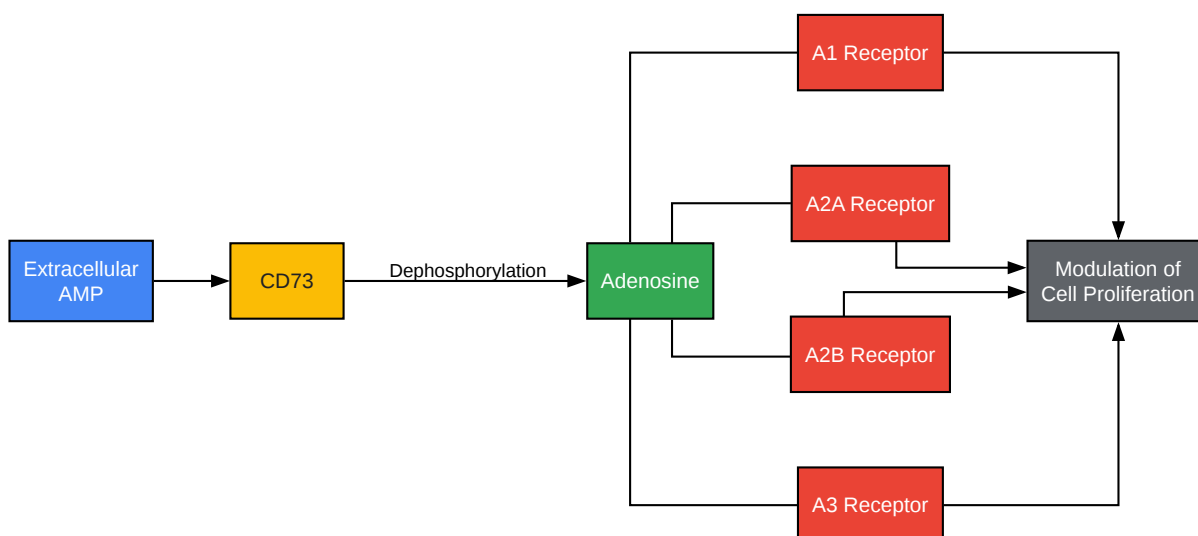
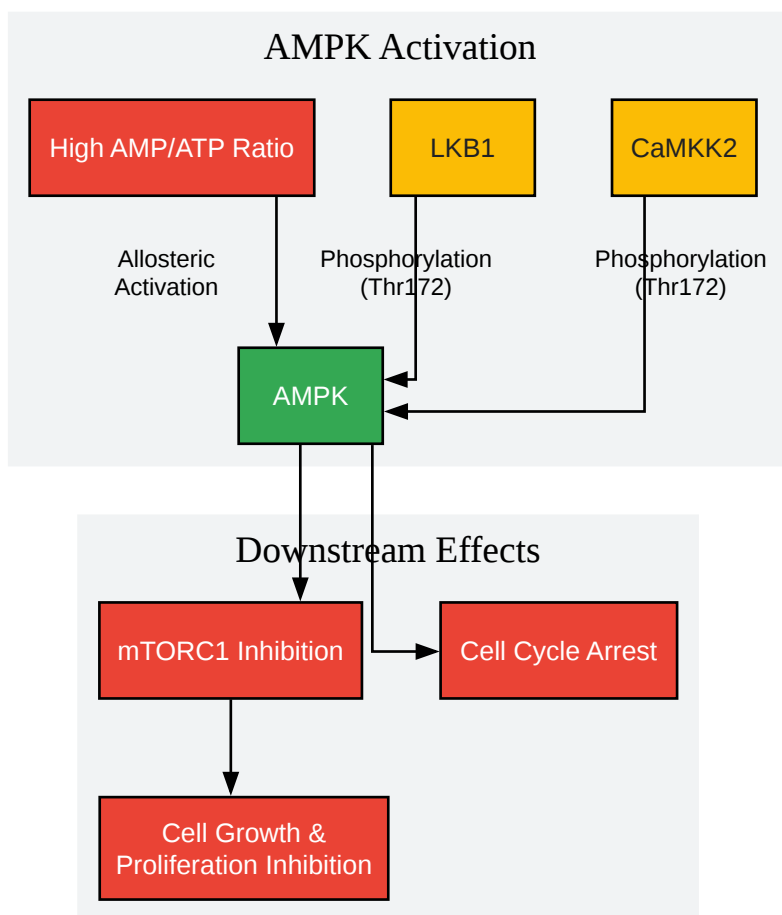

[Click to download full resolution via product page](#)

Caption: Extracellular AMP to adenosine conversion and receptor signaling.

Experimental Design & Considerations

Before proceeding with detailed protocols, it is essential to consider the experimental design.

Table 1: Key Experimental Considerations

Parameter	Recommendation	Rationale
Cell Line Selection	Choose cell lines with well-characterized metabolic profiles and expression of AMPK, CD73, and adenosine receptors.	The cellular response to AMP is highly dependent on the expression and activity of these key proteins.
AMP Concentration	Perform a dose-response study (e.g., 1 μ M to 10 mM).	To determine the optimal concentration for observing an effect and to identify potential toxicity.
Treatment Duration	Test multiple time points (e.g., 24, 48, 72 hours).	Proliferative effects can be time-dependent.
Controls	Include untreated (vehicle) controls. Consider using an AMPK activator (e.g., AICAR) or inhibitor (e.g., Compound C) as positive and negative controls for the AMPK pathway. Use adenosine receptor agonists/antagonists to dissect the role of the extracellular pathway.	To ensure observed effects are specific to the treatment and to elucidate the underlying mechanism.
Serum Conditions	Perform experiments in both serum-containing and serum-free/reduced-serum media.	Serum contains growth factors that can mask the effects of AMP. Serum-free conditions provide a more defined system.

Protocols for Cell Proliferation Assays

Here we provide detailed protocols for three widely used cell proliferation assays.

MTT Assay (Metabolic Activity)

The MTT assay is a colorimetric assay that measures the metabolic activity of cells, which is often proportional to the number of viable cells. [15] Mitochondrial dehydrogenases in living cells reduce the yellow tetrazolium salt MTT to purple formazan crystals. [15] Protocol:

- **Cell Seeding:** Seed cells in a 96-well plate at a predetermined optimal density and allow them to adhere overnight. [16] 2. **Treatment:** Remove the culture medium and add fresh medium containing various concentrations of Adenosine 5'-monophosphate sodium salt or controls.
- **Incubation:** Incubate the plate for the desired duration (e.g., 24, 48, 72 hours) at 37°C in a 5% CO₂ incubator. [17] 4. **MTT Addition:** Add 10 µL of MTT solution (5 mg/mL in PBS) to each well and incubate for 3-4 hours at 37°C. [17][18] 5. **Solubilization:** Carefully remove the medium and add 150 µL of MTT solvent (e.g., DMSO or a solution of 4 mM HCl, 0.1% NP40 in isopropanol) to each well to dissolve the formazan crystals. [16][18] 6. **Absorbance Measurement:** Shake the plate on an orbital shaker for 15 minutes to ensure complete dissolution. [18] Read the absorbance at 570-590 nm using a microplate reader. [15][18]

BrdU Incorporation Assay (DNA Synthesis)

The BrdU (5-bromo-2'-deoxyuridine) assay directly measures DNA synthesis by detecting the incorporation of the thymidine analog BrdU into the DNA of proliferating cells during the S-phase of the cell cycle. [19][20] Protocol:

- **Cell Seeding and Treatment:** Seed and treat cells with AMP as described in the MTT assay protocol.
- **BrdU Labeling:** Approximately 2-4 hours before the end of the treatment period, add BrdU labeling solution to each well to a final concentration of 10 µM. [21] Incubate for the appropriate time depending on the cell cycle length (typically 1-4 hours). [20] 3. **Fixation and Denaturation:**

- Remove the labeling medium and wash the cells with PBS.
- Fix the cells with a suitable fixative (e.g., 3.7% formaldehyde in PBS) for 15-30 minutes at room temperature. [19] * Permeabilize the cells with a detergent-based buffer (e.g., 0.1% Triton X-100 in PBS). [19] * Denature the DNA by incubating with 1-2 N HCl for 10-30 minutes at room temperature to expose the incorporated BrdU. [19][20] Neutralize with a buffering solution (e.g., 0.1 M sodium borate). [21]4. Immunodetection:
 - Block non-specific binding with a blocking buffer (e.g., PBS with 1% BSA).
 - Incubate with an anti-BrdU antibody for 1 hour at room temperature or overnight at 4°C. [19] * Wash and incubate with a fluorescently labeled secondary antibody. [19]5. Analysis: Analyze the cells using a fluorescence microscope or a flow cytometer. [22]

Colony Formation Assay (Clonogenic Survival)

The colony formation or clonogenic assay assesses the ability of a single cell to undergo enough divisions to form a colony (typically defined as >50 cells). It is a measure of long-term cell survival and reproductive integrity. Protocol:

- Cell Seeding: Prepare a single-cell suspension and seed a low number of cells (e.g., 200-1000 cells per well of a 6-well plate) in complete medium. [23]2. Treatment: Allow cells to adhere for 24 hours, then replace the medium with fresh medium containing the desired concentrations of AMP.
- Incubation: Incubate the plates for 7-14 days, allowing colonies to form. [24]Replace the treatment medium every 2-3 days. [24]4. Fixation and Staining:
 - Gently wash the colonies with PBS.
 - Fix the colonies with 100% methanol or 4% paraformaldehyde for 15-20 minutes. [23][24] * Stain the colonies with a 0.5% crystal violet solution for 10-30 minutes. [24]5. Quantification: Gently wash the wells with water and allow them to air dry. [24]Count the number of colonies in each well.

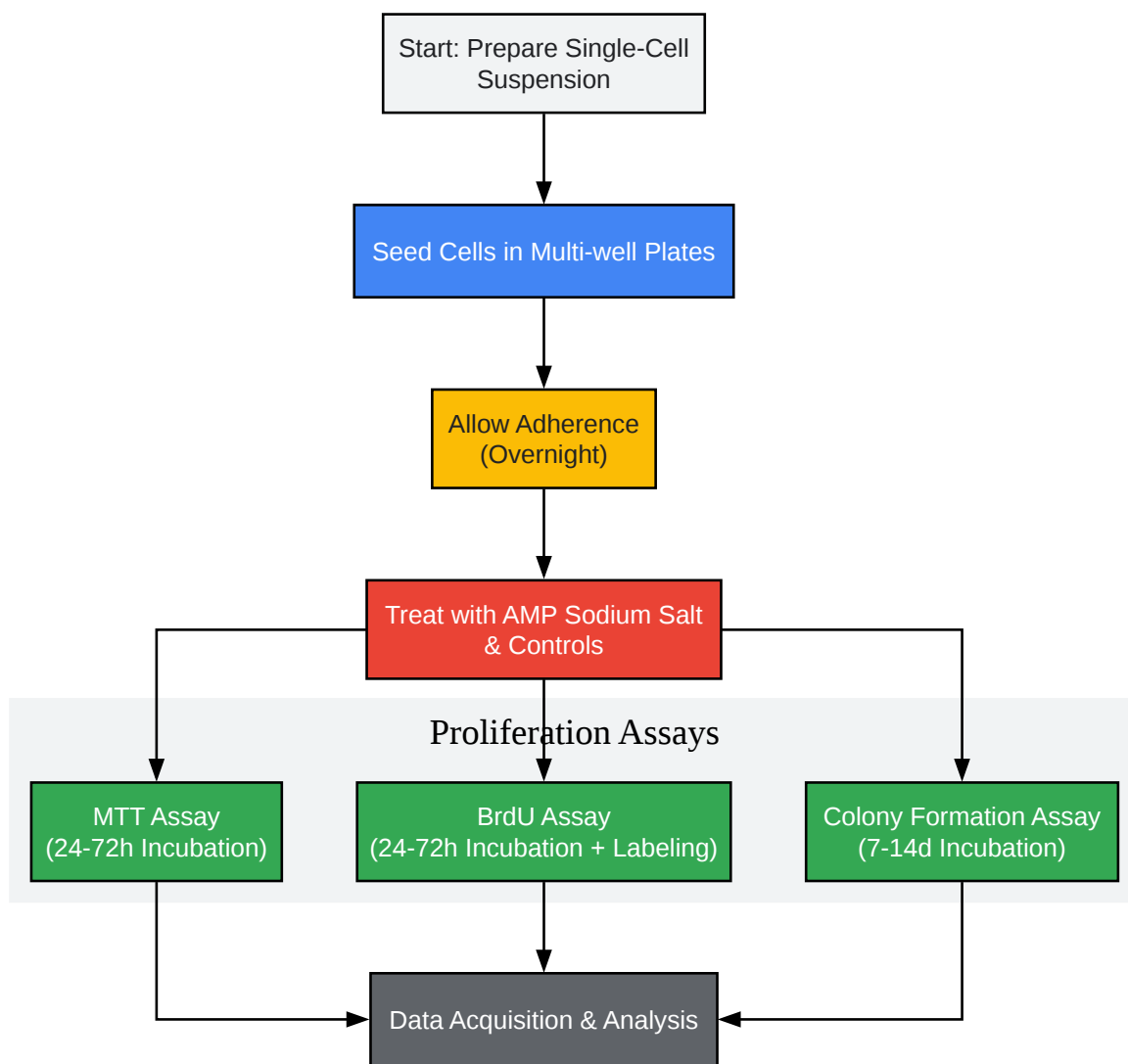

[Click to download full resolution via product page](#)

Caption: General experimental workflow for cell proliferation assays.

Data Interpretation & Troubleshooting

Table 2: Interpreting Potential Outcomes

Outcome	Possible Interpretation	Next Steps
Decreased Proliferation	AMP may be activating the AMPK pathway, leading to cell cycle arrest and inhibition of mTORC1. Alternatively, if converted to adenosine, it could be signaling through inhibitory adenosine receptors.	- Confirm AMPK activation via Western blot for phosphorylated AMPK and its downstream targets. - Use an AMPK inhibitor to see if the effect is reversed. - Use adenosine receptor antagonists to block the extracellular pathway.
Increased Proliferation	Extracellular AMP is likely being converted to adenosine, which is then signaling through pro-proliferative adenosine receptors (e.g., A2B).	- Measure adenosine levels in the culture medium. - Use a CD73 inhibitor to block the conversion of AMP to adenosine. - Use specific adenosine receptor antagonists to identify the involved receptor subtype.
No Change	The cell line may not express the necessary machinery (AMPK, CD73, responsive adenosine receptors) to respond to AMP. The concentrations or time points used may not have been optimal.	- Verify the expression of key proteins via Western blot or qPCR. - Re-evaluate the dose-response and time-course.

Troubleshooting:

- High background in MTT assay: Ensure the use of serum-free media during the MTT incubation step, as serum components can interfere with the assay. [15]* Weak signal in BrdU assay: Optimize the HCl concentration and incubation time for DNA denaturation, as this step is critical for antibody access to BrdU. [20]* Inconsistent colony formation: Ensure a true single-cell suspension is plated and that cells are evenly distributed in the wells.

Conclusion

The study of Adenosine 5'-monophosphate's effect on cell proliferation is a nuanced field requiring careful experimental design and interpretation. By understanding the underlying signaling pathways—both intracellular via AMPK and extracellular via adenosine conversion—researchers can effectively utilize the protocols outlined in this guide. These methods provide a robust framework for elucidating the role of AMP in cell cycle control and for identifying potential therapeutic applications in diseases characterized by dysregulated cell proliferation.

References

- Mihaylova, M. M., & Shaw, R. J. (2011). The AMPK signalling pathway coordinates cell growth, autophagy, and metabolism. *Nature cell biology*, 13(9), 1016–1023. Retrieved from [\[Link\]](#)
- Merighi, S., et al. (2017). Inhibition of A2A Adenosine Receptor Signaling in Cancer Cells Proliferation by the Novel Antagonist TP455. *Frontiers in Pharmacology*, 8, 873. Retrieved from [\[Link\]](#)
- Li, M., et al. (2019). The cyclic AMP signaling pathway: Exploring targets for successful drug discovery (Review). *International Journal of Molecular Medicine*, 43(3), 1135-1151. Retrieved from [\[Link\]](#)
- Chen, S., et al. (2022). Dual role of CD73 as a signaling molecule and adenosine-generating enzyme in colorectal cancer progression and immune evasion. *Journal of Translational Medicine*, 20(1), 578. Retrieved from [\[Link\]](#)
- CD73: Combating Tumor Immunosuppression by Targeting Adenosine. (2024). *Assay Genie*. Retrieved from [\[Link\]](#)
- Antonioli, L., et al. (2013). CD73 and adenosine generation in the creation of regulatory microenvironments. *Trends in immunology*, 34(2), 72–80. Retrieved from [\[Link\]](#)
- Zhu, H. (2012). Cell Proliferation Assay by Flow Cytometry (BrdU and PI Staining). *Bio-protocol*, 2(7), e198. Retrieved from [\[Link\]](#)

- Merighi, S., et al. (2002). Adenosine receptors as mediators of both cell proliferation and cell death of cultured human melanoma cells. *Journal of Investigative Dermatology*, 119(4), 924-933. Retrieved from [\[Link\]](#)
- Eigenbrodt, E., et al. (1997). Effect of extracellular AMP on cell proliferation and metabolism of breast cancer cell lines with high and low glycolytic rates. *The Journal of biological chemistry*, 272(8), 4941–4947. Retrieved from [\[Link\]](#)
- Sanli, T., et al. (2012). AMP-activated protein kinase (AMPK) beyond metabolism: a novel genomic stress sensor participating in the DNA damage response pathway. *Cancer biology & therapy*, 13(3), 156–169. Retrieved from [\[Link\]](#)
- Schuler, P. J., et al. (2019). Generation and Function of Non-cell-bound CD73 in Inflammation. *Frontiers in Immunology*, 10, 1729. Retrieved from [\[Link\]](#)
- Borowicz, S., et al. (2014). The soft agar colony formation assay. *Journal of visualized experiments : JoVE*, (92), e51998. Retrieved from [\[Link\]](#)
- BrdU Staining Protocol. (n.d.). Creative Diagnostics. Retrieved from [\[Link\]](#)
- Li, Y., et al. (2005). Cell-Signaling Evidence for Adenosine Stimulation of Coronary Smooth Muscle Proliferation via the A1 Adenosine Receptor. *Circulation Research*, 97(4), 367-374. Retrieved from [\[Link\]](#)
- Miyamoto, T., et al. (2016). AMPK Causes Cell Cycle Arrest in LKB1-Deficient Cells via Activation of CAMKK2. *Cell reports*, 16(7), 1747–1755. Retrieved from [\[Link\]](#)
- Kalender, A., et al. (2014). Discrete mechanisms of mTOR and cell cycle regulation by AMPK agonists independent of AMPK. *Proceedings of the National Academy of Sciences of the United States of America*, 111(4), E439-E448. Retrieved from [\[Link\]](#)
- Borea, P. A., et al. (2024). Current Understanding of the Role of Adenosine Receptors in Cancer. *International Journal of Molecular Sciences*, 25(15), 8171. Retrieved from [\[Link\]](#)
- dos Santos, R. S., et al. (2014). Adenosine uptake is the major effector of extracellular ATP toxicity in human cervical cancer cells. *Molecular biology of the cell*, 25(15), 2389–2398. Retrieved from [\[Link\]](#)

- Miyamoto, T., et al. (2016). AMPK Causes Cell Cycle Arrest in LKB1-deficient Cells via Activation of CAMKK2. *Cell reports*, 16(7), 1747–1755. Retrieved from [\[Link\]](#)
- Li, M., et al. (2019). The cyclic AMP signaling pathway: Exploring targets for successful drug discovery (Review). *International Journal of Molecular Medicine*, 43(3), 1135-1151. Retrieved from [\[Link\]](#)
- The Soft Agar Colony Formation Assay. (2014). JoVE. Retrieved from [\[Link\]](#)
- Ross, F. A., et al. (2020). AMP-Activated Protein Kinase: Do We Need Activators or Inhibitors to Treat or Prevent Cancer?. *International journal of molecular sciences*, 22(1), 187. Retrieved from [\[Link\]](#)
- Sathyajith, D. (2020). AMPK Signaling Pathway. News-Medical. Retrieved from [\[Link\]](#)
- Sharma, S., et al. (2021). Extracellular ATP Mediates Cancer Cell Migration and Invasion Through Increased Expression of Cyclooxygenase 2. *Frontiers in oncology*, 11, 655383. Retrieved from [\[Link\]](#)
- Sharma, S., et al. (2021). Extracellular ATP enhances cancer cell migration and invasion. ResearchGate. Retrieved from [\[Link\]](#)
- Jacobson, K. A., & Müller, C. E. (2018). Pharmacology of Adenosine Receptors: The State of the Art. *Physiological reviews*, 98(3), 1591–1620. Retrieved from [\[Link\]](#)
- Multiparametric Cell Proliferation and Cytotoxicity Assay. (n.d.). Agilent. Retrieved from [\[Link\]](#)
- Cell Viability Assay (MTT Assay) Protocol. (2023). protocols.io. Retrieved from [\[Link\]](#)
- Cytotoxicity assays of AMPs. (n.d.). ResearchGate. Retrieved from [\[Link\]](#)
- MTT Proliferation Assay Protocol. (2025). ResearchGate. Retrieved from [\[Link\]](#)

Need Custom Synthesis?

BenchChem offers custom synthesis for rare earth carbides and specific isotopic labeling.

Email: info@benchchem.com or [Request Quote Online](#).

Sources

- 1. The AMP-activated protein kinase (AMPK) signaling pathway coordinates cell growth, autophagy, & metabolism - PMC [[pmc.ncbi.nlm.nih.gov](https://pubmed.ncbi.nlm.nih.gov)]
- 2. [news-medical.net](https://www.news-medical.net) [[news-medical.net](https://www.news-medical.net)]
- 3. What are CD73 modulators and how do they work? [synapse.patsnap.com]
- 4. Dual role of CD73 as a signaling molecule and adenosine-generating enzyme in colorectal cancer progression and immune evasion - PMC [[pmc.ncbi.nlm.nih.gov](https://pubmed.ncbi.nlm.nih.gov)]
- 5. [assaygenie.com](https://www.assaygenie.com) [[assaygenie.com](https://www.assaygenie.com)]
- 6. CD73 and adenosine generation in the creation of regulatory microenvironments - PMC [[pmc.ncbi.nlm.nih.gov](https://pubmed.ncbi.nlm.nih.gov)]
- 7. Frontiers | Inhibition of A2A Adenosine Receptor Signaling in Cancer Cells Proliferation by the Novel Antagonist TP455 [[frontiersin.org](https://www.frontiersin.org)]
- 8. Adenosine receptors as mediators of both cell proliferation and cell death of cultured human melanoma cells - PubMed [pubmed.ncbi.nlm.nih.gov]
- 9. [mdpi.com](https://www.mdpi.com) [[mdpi.com](https://www.mdpi.com)]
- 10. [molbiolcell.org](https://www.molbiolcell.org) [[molbiolcell.org](https://www.molbiolcell.org)]
- 11. AMP-activated protein kinase (AMPK) beyond metabolism: A novel genomic stress sensor participating in the DNA damage response pathway - PMC [[pmc.ncbi.nlm.nih.gov](https://pubmed.ncbi.nlm.nih.gov)]
- 12. [pnas.org](https://www.pnas.org) [[pnas.org](https://www.pnas.org)]
- 13. [aacrjournals.org](https://www.aacrjournals.org) [[aacrjournals.org](https://www.aacrjournals.org)]
- 14. [mdpi.com](https://www.mdpi.com) [[mdpi.com](https://www.mdpi.com)]
- 15. MTT assay protocol | Abcam [[abcam.com](https://www.abcam.com)]
- 16. [researchgate.net](https://www.researchgate.net) [[researchgate.net](https://www.researchgate.net)]
- 17. [merckmillipore.com](https://www.merckmillipore.com) [[merckmillipore.com](https://www.merckmillipore.com)]
- 18. [cyrusbio.com.tw](https://www.cyrusbio.com.tw) [[cyrusbio.com.tw](https://www.cyrusbio.com.tw)]
- 19. BrdU Labeling & Detection Protocol | Thermo Fisher Scientific - JP [[thermofisher.com](https://www.thermofisher.com)]
- 20. BrdU staining and BrdU assay protocol | Abcam [[abcam.com](https://www.abcam.com)]
- 21. [bio-protocol.org](https://www.bio-protocol.org) [[bio-protocol.org](https://www.bio-protocol.org)]
- 22. BrdU Staining Protocol for Flow Cytometry | Thermo Fisher Scientific - HK [[thermofisher.com](https://www.thermofisher.com)]

- [23. ossila.com \[ossila.com\]](#)
- [24. benchchem.com \[benchchem.com\]](#)
- To cite this document: BenchChem. [Application Note & Protocols: Investigating Cell Proliferation with Adenosine 5'-monophosphate (AMP)]. BenchChem, [2026]. [Online PDF]. Available at: [<https://www.benchchem.com/product/b13397499/docs#application-note-protocols-investigating-cell-proliferation-with-adenosine-5-monophosphate-amp>]

Disclaimer & Data Validity:

The information provided in this document is for Research Use Only (RUO) and is strictly not intended for diagnostic or therapeutic procedures. While BenchChem strives to provide accurate protocols, we make no warranties, express or implied, regarding the fitness of this product for every specific experimental setup.

Technical Support: The protocols provided are for reference purposes. Unsure if this reagent suits your experiment?

Need Industrial/Bulk Grade? [Request Custom Synthesis Quote](#)

BenchChem

Our mission is to be the trusted global source of essential and advanced chemicals, empowering scientists and researchers to drive progress in science and industry.

Contact

Address: 3281 E Guasti Rd

Ontario, CA 91761, United States

Phone: (601) 213-4426

Email: info@benchchem.com

[Contact our Ph.D. Support Team for a compatibility check](#)