

Validating Peptide Sequences by Tandem Mass Spectrometry: A Comparative Guide

Author: BenchChem Technical Support Team. **Date:** February 2026

Compound of Interest

Compound Name: *Fmoc-3-(trifluoromethyl)-L-phenylalanine*

Cat. No.: *B13396454*

[Get Quote](#)

In the realms of proteomics, drug development, and molecular biology, the precise determination of a peptide's amino acid sequence is paramount. It forms the bedrock of protein identification, the characterization of post-translational modifications (PTMs), and the design of novel therapeutics.[1][2] Tandem mass spectrometry (MS/MS) has emerged as the cornerstone technology for peptide sequencing, offering unparalleled sensitivity and throughput.[1][3][4] This guide provides an in-depth comparison of the primary methodologies for validating peptide sequences using MS/MS, offering insights into experimental design and data interpretation to empower researchers in their scientific endeavors.

The Imperative of Sequence Validation

A peptide's function is intrinsically linked to its primary structure—the linear arrangement of amino acids. Even minor variations can dramatically alter its biological activity. Therefore, robust validation of a peptide's sequence is not merely a confirmatory step but a critical component of rigorous scientific investigation. This is especially crucial in applications such as the development of peptide-based drugs, where sequence accuracy directly impacts efficacy and safety, and in proteomics research for the unambiguous identification of proteins and their modified forms.[1]

Core Methodologies: A Comparative Overview

Two principal strategies dominate the landscape of peptide sequence validation by tandem mass spectrometry: database searching and de novo sequencing. While both leverage the

fragmentation patterns of peptides, they differ fundamentally in their approach.

Feature	Database Searching	De Novo Sequencing
Principle	Matches experimental MS/MS spectra against theoretical spectra generated from a protein sequence database.[5][6]	Derives the peptide sequence directly from the mass differences between fragment ions in an MS/MS spectrum.[7][8][9]
Requirement	A comprehensive protein sequence database for the organism of interest.[6]	No prior sequence information is required.[7][10]
Strengths	High-throughput and computationally efficient for known proteins. Generally provides higher confidence for peptides present in the database.[11]	Enables the identification of novel peptides, uncharacterized proteins, and sequences from organisms with unsequenced genomes. [10] Crucial for antibody sequencing and identifying unexpected variants.[10][12]
Limitations	Cannot identify peptides not present in the database (e.g., from novel proteins, mutations, or unexpected PTMs).[7] The completeness of the database is a critical limiting factor.[7]	Computationally intensive and can be more prone to errors, especially with lower quality spectra.[10][11] Incomplete fragment ion series can lead to ambiguous or incorrect sequence calls.[8]
Best Suited For	Large-scale proteome identification and quantification in well-characterized organisms.	Analysis of novel proteins, antibodies, venoms, and metaproteomics.[7] Confirmation of database search results and identification of unexpected modifications.[8]

The Tandem Mass Spectrometry Workflow: A Step-by-Step Protocol

The successful validation of a peptide sequence is contingent on a meticulously executed experimental workflow. This process can be broadly categorized into three key stages: sample preparation, LC-MS/MS analysis, and data interpretation.

Experimental Workflow Diagram

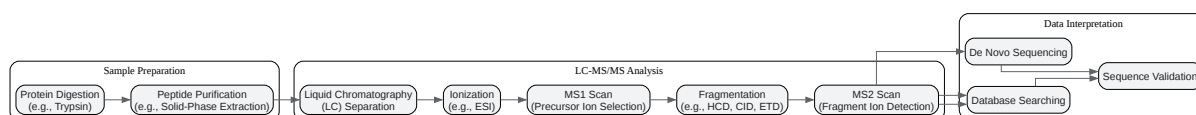

[Click to download full resolution via product page](#)

Caption: A generalized workflow for peptide sequence validation by tandem mass spectrometry.

Detailed Protocol:

- **Protein Digestion:** For protein samples, enzymatic digestion is necessary to generate peptides of a suitable size for MS analysis.^[1] Trypsin is the most commonly used protease due to its high specificity, cleaving C-terminal to arginine and lysine residues.
- **Peptide Purification:** The resulting peptide mixture is purified and concentrated using solid-phase extraction (SPE) to remove salts and other contaminants that can interfere with ionization.
- **Liquid Chromatography (LC) Separation:** The purified peptides are separated based on their hydrophobicity using reversed-phase liquid chromatography. This reduces the complexity of the sample entering the mass spectrometer at any given time.

- Ionization: As peptides elute from the LC column, they are ionized, most commonly by electrospray ionization (ESI), which generates multiply charged ions.
- MS1 Scan (Precursor Ion Selection): The mass spectrometer performs a survey scan (MS1) to determine the mass-to-charge (m/z) ratios of the intact peptide ions.
- Fragmentation: Selected precursor ions are isolated and subjected to fragmentation. Several techniques are available, each with its own advantages.
- MS2 Scan (Fragment Ion Detection): The m/z ratios of the resulting fragment ions are measured in a second scan (MS2), generating a tandem mass spectrum.
- Data Interpretation: The acquired MS/MS spectra are then interpreted using either database searching or de novo sequencing algorithms to determine the peptide sequence.

A Deeper Dive into Fragmentation Techniques

The choice of fragmentation method is a critical parameter that significantly influences the quality of the MS/MS spectrum and, consequently, the confidence in sequence validation. The three most prevalent techniques are Collision-Induced Dissociation (CID), Higher-Energy Collisional Dissociation (HCD), and Electron Transfer Dissociation (ETD).

Fragmentation Mechanisms Diagram

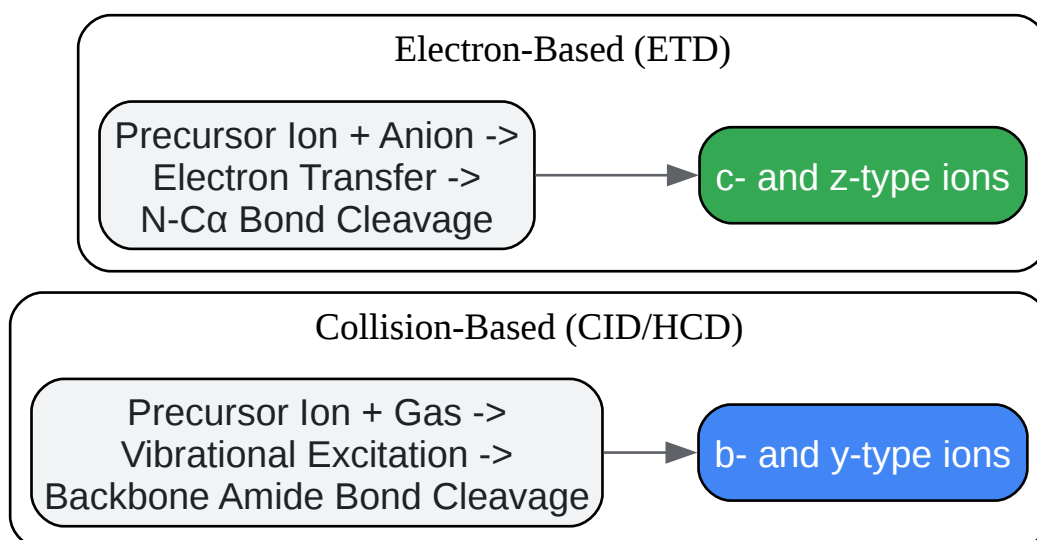

[Click to download full resolution via product page](#)

Need Custom Synthesis?

BenchChem offers custom synthesis for rare earth carbides and specific isotopic labeling.

Email: info@benchchem.com or [Request Quote Online](#).

Sources

- [1. Peptide Sequencing: Principles, Techniques, and Research Applications - Creative Proteomics \[creative-proteomics.com\]](#)
- [2. resolvemass.ca \[resolvemass.ca\]](#)
- [3. Peptide Sequencing: Methods, Applications, and Advances in Proteomics - MetwareBio \[metwarebio.com\]](#)
- [4. Applications of Tandem Mass Spectrometry \(MS/MS\) in Protein Analysis for Biomedical Research - PMC \[pmc.ncbi.nlm.nih.gov\]](#)
- [5. academic.oup.com \[academic.oup.com\]](#)
- [6. books.rsc.org \[books.rsc.org\]](#)
- [7. ijcai.org \[ijcai.org\]](#)
- [8. books.rsc.org \[books.rsc.org\]](#)
- [9. creative-biolabs.com \[creative-biolabs.com\]](#)
- [10. Advantages and Disadvantages of De Novo Peptide Sequencing | MtoZ Biolabs \[mtoz-biolabs.com\]](#)
- [11. Current algorithmic solutions for peptide-based proteomics data generation and identification - PMC \[pmc.ncbi.nlm.nih.gov\]](#)
- [12. academic.oup.com \[academic.oup.com\]](#)
- To cite this document: BenchChem. [Validating Peptide Sequences by Tandem Mass Spectrometry: A Comparative Guide]. BenchChem, [2026]. [Online PDF]. Available at: [\[https://www.benchchem.com/product/b13396454#validation-of-peptide-sequence-by-tandem-mass-spectrometry\]](https://www.benchchem.com/product/b13396454#validation-of-peptide-sequence-by-tandem-mass-spectrometry)

Disclaimer & Data Validity:

The information provided in this document is for Research Use Only (RUO) and is strictly not intended for diagnostic or therapeutic procedures. While BenchChem strives to provide accurate protocols, we make no warranties, express or implied, regarding the fitness of this product for every specific experimental setup.

Technical Support: The protocols provided are for reference purposes. Unsure if this reagent suits your experiment? [[Contact our Ph.D. Support Team for a compatibility check](#)]

Need Industrial/Bulk Grade? [Request Custom Synthesis Quote](#)

BenchChem

Our mission is to be the trusted global source of essential and advanced chemicals, empowering scientists and researchers to drive progress in science and industry.

Contact

Address: 3281 E Guasti Rd
Ontario, CA 91761, United States
Phone: (601) 213-4426
Email: info@benchchem.com