

PTB7-Th in Tandem Solar Cells: A Comparative Performance Analysis

Author: BenchChem Technical Support Team. **Date:** April 2026

Compound of Interest

Compound Name: PTB7-Th
Cat. No.: B13395056

Get Quote

The donor polymer **PTB7-Th** has demonstrated significant potential in enhancing the efficiency of organic photovoltaic (OPV) devices, particularly within tandem solar cell architectures. These complex structures, which stack multiple solar cell sub-units to capture a broader range of the solar spectrum, have seen notable performance improvements when incorporating this low-bandgap polymer. This guide provides a comparative analysis of **PTB7-Th**'s performance in various tandem configurations, supported by experimental data, and contrasts it with alternative polymer donors.

Performance of PTB7-Th in Tandem Architectures

PTB7-Th has been successfully integrated into both all-polymer and fullerene-based tandem solar cells, exhibiting promising power conversion efficiencies (PCEs). In a homo-tandem configuration, where both the front and rear cells utilize the same **PTB7-Th**:PC₇₁BM active layer blend, a remarkable PCE of 11.3% has been reported.[1] This demonstrates the material's versatility and effectiveness in a stacked geometry.

Furthermore, **PTB7-Th** has been employed in non-fullerene acceptor (NFA) based tandem solar cells, achieving a high efficiency of 14.11%.[2] In this architecture, **PTB7-Th** was paired with the NFA NOBDT in the rear sub-cell to complement a front sub-cell based on the wide-

bandgap polymer PBDB-T and the NFA F-M.[2] This highlights the adaptability of **PTB7-Th** in combination with a variety of acceptor materials to optimize light absorption and device performance.

A parallel-connected tandem device featuring **PTB7-Th** and a non-fullerene acceptor, 4TIC, has also demonstrated a high PCE of 11.20%. This configuration offers an alternative approach to the more common series-connected tandem cells.

Comparison with Alternative Polymer Donors

While **PTB7-Th** has shown impressive results, several other polymers are also utilized in high-performance tandem solar cells. For a comprehensive comparison, the performance of tandem cells based on PCE10 (a synonym for **PTB7-Th**) and J51 are also considered.

Donor Polymer	Acceptor(s)	Tandem Architecture	PCE (%)	Voc (V)	Jsc (mA/cm ²)	FF (%)	Reference
PTB7-Th	PC ₇₁ BM	Homo-Tandem (Series)	11.3	1.54	11.1	-	[1]
PTB7-Th	NOBDT (rear) / F-M (front)	Hetero-Tandem (Series)	14.11	-	12.15	-	[2]
P2F-DO	N2200	All-Polymer Homo-Tandem	6.70	1.58	7.31	58	[3]
PIDT-phanQ	PC ₆₁ BM / PC ₇₁ BM	Hetero-Tandem	8.5	1.71	6.91	65.7	[4]
PCPDTFBT	PC ₆₁ BM / PC ₇₁ BM	Hetero-Tandem	7.9	-	-	-	[4]

Note: Direct, side-by-side comparative data for PCE10 and J51 in tandem architectures under identical conditions is limited in the reviewed literature. The table presents a broader

comparison of different polymer-based tandem cells to provide context for **PTB7-Th**'s performance.

Experimental Protocols

Detailed experimental procedures are crucial for reproducing and building upon research findings. Below are generalized fabrication steps for a solution-processed organic tandem solar cell, based on common practices reported in the literature.

General Device Fabrication Protocol:

- **Substrate Preparation:** Indium tin oxide (ITO)-coated glass substrates are sequentially cleaned in ultrasonic baths of detergent, deionized water, acetone, and isopropanol. The substrates are then treated with UV-ozone or oxygen plasma to improve the work function and ensure a clean surface.[5]
- **Hole Transport Layer (HTL) Deposition:** A solution of PEDOT:PSS is typically spin-coated onto the cleaned ITO substrates and annealed. This layer facilitates the transport of holes to the anode.[5]
- **Front Cell Active Layer Deposition:** A solution of the wide-bandgap polymer donor and acceptor (e.g., **PTB7-Th**:PC₇₁BM) in a solvent like chlorobenzene with an additive such as 1,8-diiodooctane (DIO) is spin-coated in an inert atmosphere (e.g., a nitrogen-filled glovebox). The film is then annealed to optimize its morphology.
- **Interconnecting Layer (ICL) Deposition:** The ICL is a critical component that connects the front and rear sub-cells. A common ICL consists of a pH-neutral, alcohol-soluble polymer layer followed by a layer of ZnO nanoparticles. This layer must be optically transparent and electrically efficient to facilitate charge recombination between the sub-cells.
- **Rear Cell Active Layer Deposition:** The active layer for the rear cell, typically comprising a low-bandgap polymer donor like **PTB7-Th** and an acceptor, is then spin-coated on top of the ICL.
- **Electron Transport Layer (ETL) and Cathode Deposition:** Finally, an electron transport layer (e.g., Ca, Al) and a top metal electrode (e.g., Al) are deposited via thermal evaporation under high vacuum to complete the device.

Tandem Solar Cell Architecture

The fundamental structure of a series-connected tandem solar cell is designed to maximize the absorption of the solar spectrum and the overall output voltage.

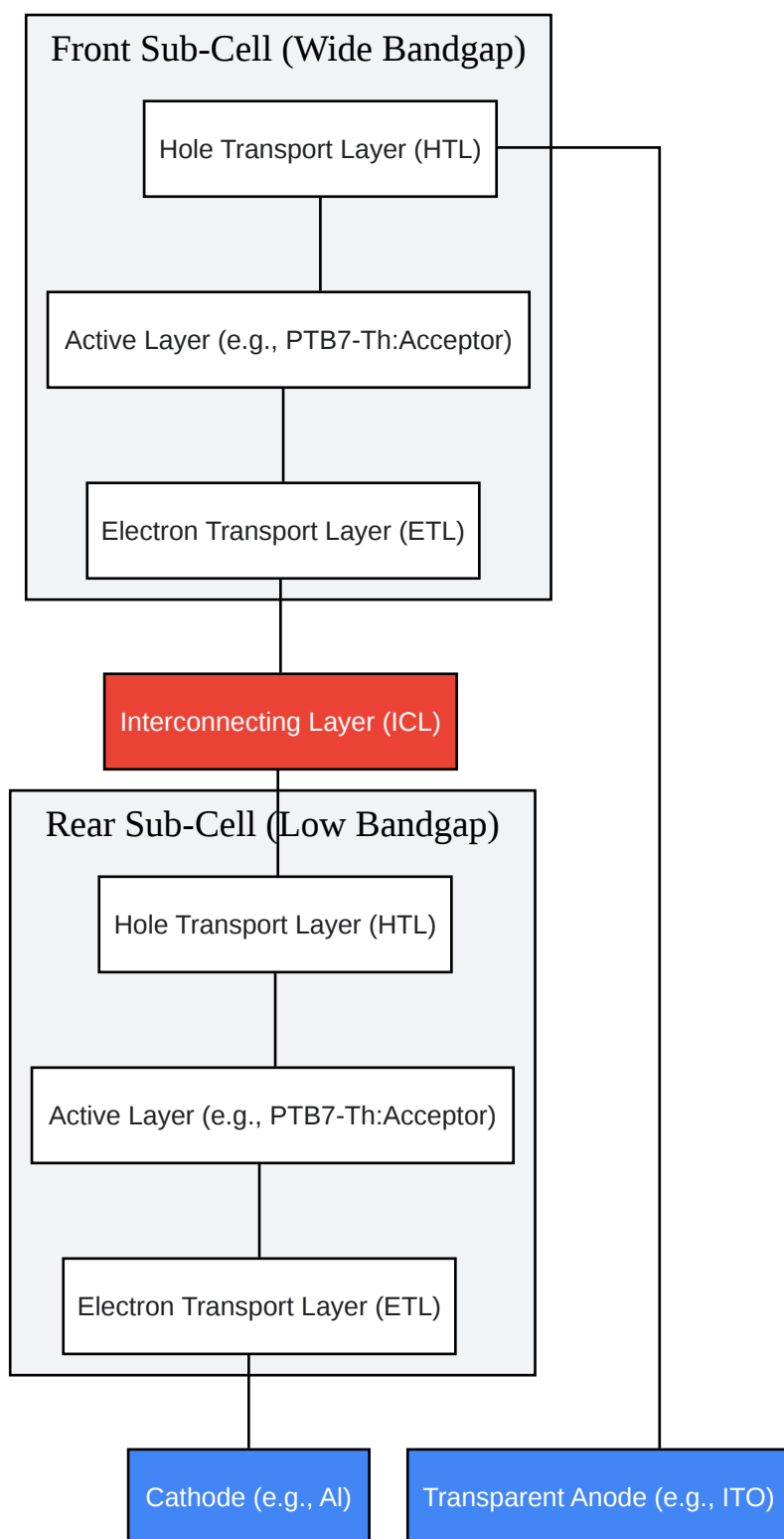

[Click to download full resolution via product page](#)

Caption: A schematic of a series-connected tandem solar cell architecture.

In conclusion, **PTB7-Th** stands out as a high-performing and versatile polymer donor for tandem solar cell applications. Its demonstrated success in various architectures, including both fullerene and non-fullerene based systems, underscores its importance in the ongoing development of more efficient organic photovoltaic technologies. Further research focusing on direct, side-by-side comparisons with other leading polymers under standardized conditions will be crucial for a definitive assessment of its relative performance.

Need Custom Synthesis?

BenchChem offers custom synthesis for rare earth carbides and specific isotopic labeling.

Email: info@benchchem.com or [Request Quote Online](#).

References

- [1. researchgate.net](https://www.researchgate.net) [[researchgate.net](https://www.researchgate.net)]
- [2. nanocenter.nankai.edu.cn](https://nanocenter.nankai.edu.cn) [nanocenter.nankai.edu.cn]
- [3. High efficiency all-polymer tandem solar cells - PMC](https://pubmed.ncbi.nlm.nih.gov/) [[pmc.ncbi.nlm.nih.gov](https://pubmed.ncbi.nlm.nih.gov/)]
- [4. ir.lib.nycu.edu.tw](https://ir.lib.nycu.edu.tw) [ir.lib.nycu.edu.tw]
- [5. researchgate.net](https://www.researchgate.net) [[researchgate.net](https://www.researchgate.net)]
- To cite this document: BenchChem. [PTB7-Th in Tandem Solar Cells: A Comparative Performance Analysis]. BenchChem, [2026]. [Online PDF]. Available at: [<https://www.benchchem.com/product/b13395056/docs#ptb7-th-in-tandem-solar-cells-a-comparative-performance-analysis>]

Disclaimer & Data Validity:

The information provided in this document is for Research Use Only (RUO) and is strictly not intended for diagnostic or therapeutic procedures. While BenchChem strives to provide accurate protocols, we make no warranties, express or implied, regarding the fitness of this product for every specific experimental setup.

Technical Support: The protocols provided are for reference purposes. Unsure if this reagent suits your experiment?

Need Industrial/Bulk Grade? [Request Custom Synthesis Quote](#)

BenchChem

Our mission is to be the trusted global source of essential and advanced chemicals, empowering scientists and researchers to drive progress in science and industry.

Contact

Address: 3281 E Guasti Rd
Ontario, CA 91761, United States
Phone: (601) 213-4426
Email: info@benchchem.com

[Contact our Ph.D. Support Team for a compatibility check](#)