

# A Comparative Guide to High-Efficiency PTB7-Th Solar Cells

**Author:** BenchChem Technical Support Team. **Date:** April 2026

## Compound of Interest

Compound Name: PTB7-Th  
Cat. No.: B13395056

[Get Quote](#)

The quest for efficient and stable organic solar cells (OSCs) has led to the development of a plethora of photoactive materials. Among them, the polymer donor **PTB7-Th** has emerged as a workhorse material, consistently delivering high power conversion efficiencies (PCEs) in various device architectures. This guide provides a comprehensive literature review of high-efficiency solar cells based on **PTB7-Th**, offering a comparative analysis of their performance with different acceptor materials and processing conditions. Detailed experimental protocols for fabricating high-performing devices are also presented to aid researchers in the field.

## Performance Benchmark of PTB7-Th Based Solar Cells

The versatility of **PTB7-Th** allows for its successful pairing with both fullerene and non-fullerene acceptors (NFAs), leading to impressive device performance. The following tables summarize the key photovoltaic parameters of high-efficiency **PTB7-Th** based solar cells reported in the literature.

Donor:Acceptor	Device Architecture	Voc (V)	Jsc (mA/cm <sup>2</sup> )	FF (%)	PCE (%)	Reference
PTB7-Th:PC71BM	Inverted	0.82	19.1	69.1	10.8	[1]
PTB7-Th:PC71BM	Inverted	~0.75	~17.5	~70	~9.0	[2][3]
PTB7-Th:ITCT	Inverted	0.95	15.13	72	10.42	[4]
PTB7-Th:O-IDTBR	Conventional	1.00	15.44	64.6	9.94	
PTB7-Th:Y6:PC71BM	Conventional	0.85	24.68	73.1	9.55	[5]
PTB7-Th:EH-IDTBr:T2-ORH	Conventional	1.05	17.51	63	11.55	[6]

## Experimental Protocols for High-Performance Devices

The fabrication of high-efficiency organic solar cells is highly sensitive to the processing conditions. Below are detailed experimental protocols for some of the top-performing **PTB7-Th** based devices.

### PTB7-Th:PC71BM based on Binary Solvent Additives[1]

- Device Structure: ITO/ZnO/PTB7-Th:PC71BM/MoO<sub>3</sub>/Ag

- Active Layer Solution: **PTB7-Th** and PC71BM (1:1.5 weight ratio) were dissolved in ortho-dichlorobenzene (o-DCB) to a total concentration of 25 mg/mL. A mixed solvent additive of 1,8-diiodooctane (DIO) and N-methyl-2-pyrrolidone (NMP) was added to the solution.
- Device Fabrication:
  - Patterned ITO-coated glass substrates were cleaned sequentially in an ultrasonic bath with detergent, deionized water, acetone, and isopropanol.
  - A ZnO precursor solution was spin-coated onto the ITO substrates and annealed at 200 °C for 60 minutes in air to form an electron transport layer.
  - The active layer solution was spin-coated on top of the ZnO layer in a nitrogen-filled glovebox.
  - A MoO<sub>3</sub> layer (10 nm) and an Ag electrode (100 nm) were thermally evaporated onto the active layer through a shadow mask.

## PTB7-Th:ITCT Non-Fullerene Solar Cell[4]

- Device Structure: ITO/ZnO/**PTB7-Th**:ITCT/MoO<sub>3</sub>/Ag
- Active Layer Solution: **PTB7-Th** and ITCT were dissolved in chlorobenzene with 0.1% DIO as an additive.
- Device Fabrication:
  - ITO-coated glass substrates were cleaned and treated with UV-ozone.
  - A ZnO nanoparticle layer was spin-coated and annealed.
  - The active layer solution was spin-coated in a glovebox.
  - The devices were then subjected to thermal annealing.
  - Finally, MoO<sub>3</sub> and Ag were thermally evaporated as the hole transport layer and top electrode, respectively.

## PTB7-Th:Y6:PC71BM Ternary Solar Cell[5]

- Device Structure: ITO/PEDOT:PSS/PTB7-Th:Y6:PC71BM/AZO/Al
- Active Layer Solution: PTB7-Th, Y6, and PC71BM were dissolved in chloroform.
- Device Fabrication:
  - ITO substrates were cleaned and spin-coated with a PEDOT:PSS layer, followed by annealing.
  - The ternary active layer solution was spin-coated in a glovebox.
  - An aluminum-doped zinc oxide (AZO) layer and an aluminum (Al) electrode were deposited by sputtering and thermal evaporation, respectively.

## Visualizing Key Processes and Structures

To better understand the fundamental aspects of PTB7-Th based solar cells, the following diagrams illustrate the device architecture, a typical experimental workflow, and the crucial energy level alignment.

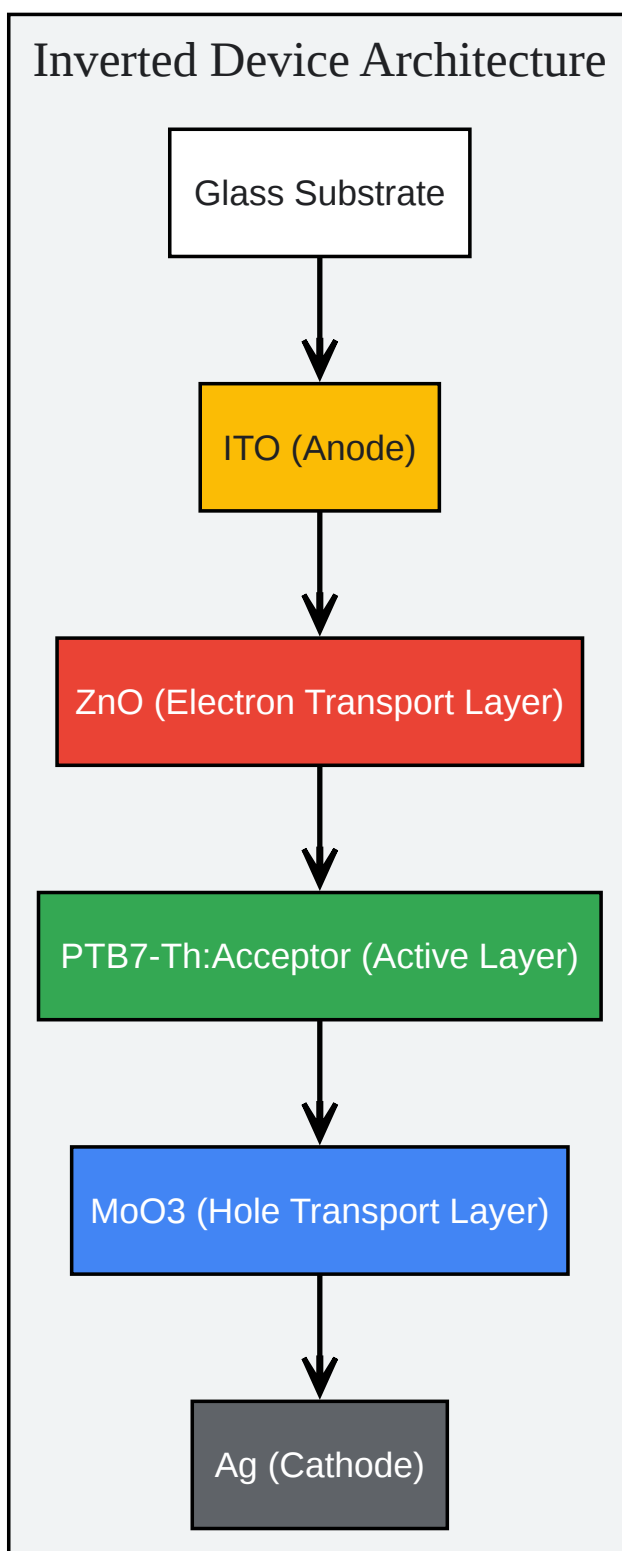

[Click to download full resolution via product page](#)

Caption: A typical inverted device architecture for **PTB7-Th** solar cells.

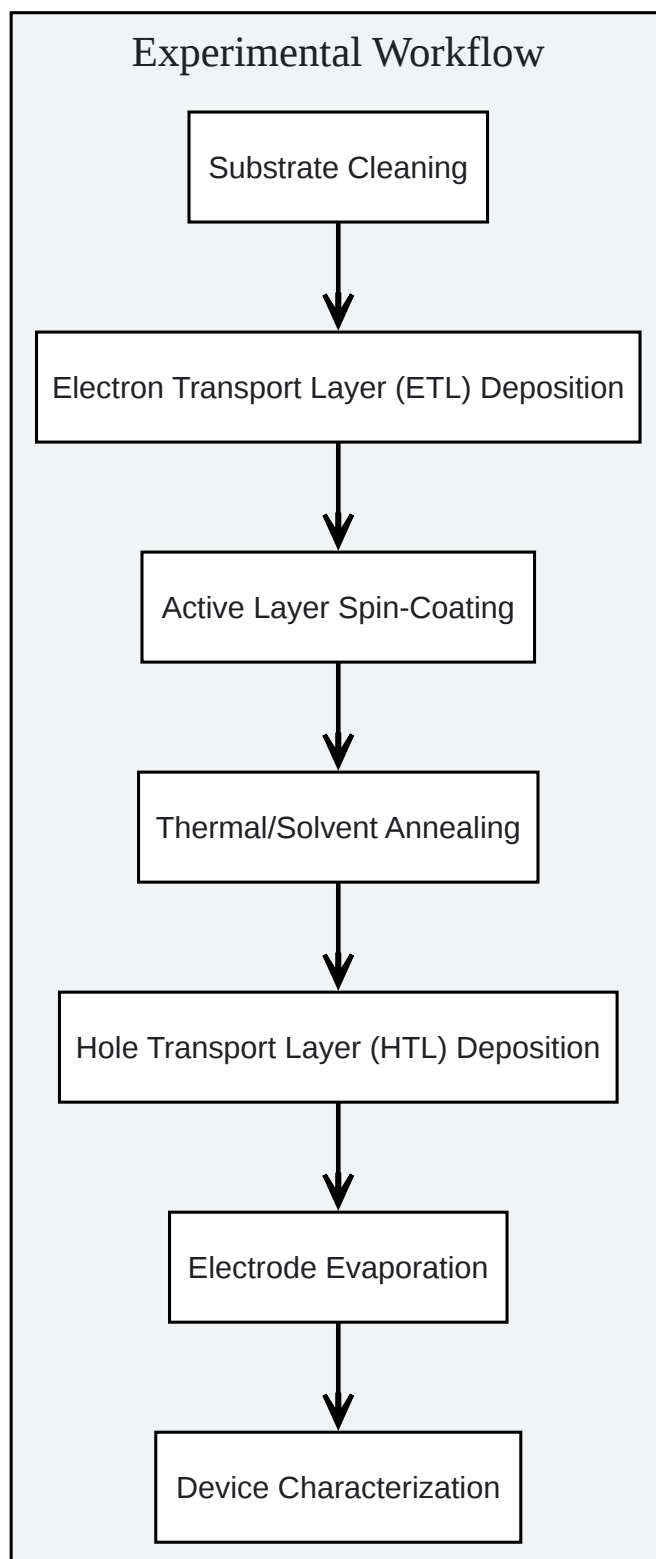

[Click to download full resolution via product page](#)

Caption: A generalized experimental workflow for fabricating organic solar cells.

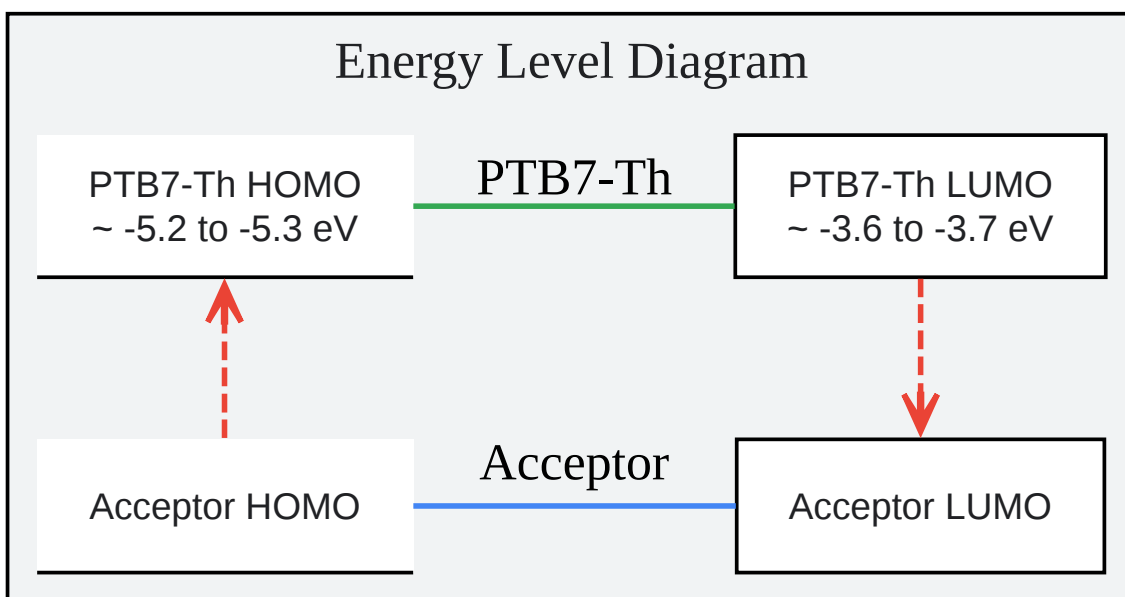

[Click to download full resolution via product page](#)

Caption: Energy level diagram illustrating charge transfer in a **PTB7-Th**:Acceptor blend.

### Need Custom Synthesis?

BenchChem offers custom synthesis for rare earth carbides and specific isotopic labeling.

Email: [info@benchchem.com](mailto:info@benchchem.com) or [Request Quote Online](#).

## References

- 1. 10.8% Efficiency Polymer Solar Cells Based on PTB7-Th and PC>71>BM via Binary Solvent Additives Treatment - 西安交通大学 [scholar.xjtu.edu.cn:443]
- 2. researchgate.net [researchgate.net]
- 3. academic.oup.com [academic.oup.com]
- 4. researchgate.net [researchgate.net]
- 5. researchgate.net [researchgate.net]
- 6. Enhanced efficiency and stability of PTB7-Th-based multi-non-fullerene solar cells enabled by the working mechanism of the coexisting alloy-like structure and energy transfer model - Journal of Materials Chemistry A (RSC Publishing) [pubs.rsc.org]

- To cite this document: BenchChem. [A Comparative Guide to High-Efficiency PTB7-Th Solar Cells]. BenchChem, [2026]. [Online PDF]. Available at: [<https://www.benchchem.com/product/b13395056/docs#a-comparative-guide-to-high-efficiency-ptb7-th-solar-cells>]

---

### Disclaimer & Data Validity:

The information provided in this document is for Research Use Only (RUO) and is strictly not intended for diagnostic or therapeutic procedures. While BenchChem strives to provide accurate protocols, we make no warranties, express or implied, regarding the fitness of this product for every specific experimental setup.

**Technical Support:** The protocols provided are for reference purposes. Unsure if this reagent suits your experiment?

**Need Industrial/Bulk Grade?** [Request Custom Synthesis Quote](#)

## BenchChem

Our mission is to be the trusted global source of essential and advanced chemicals, empowering scientists and researchers to drive progress in science and industry.

### Contact

Address: 3281 E Guasti Rd

Ontario, CA 91761, United States

Phone: (601) 213-4426

Email: [info@benchchem.com](mailto:info@benchchem.com)

[Contact our Ph.D. Support Team for a compatibility check](#)