

# An In-depth Technical Guide to Tyr-Somatostatin-14 Signaling Pathways

**Author:** BenchChem Technical Support Team. **Date:** April 2026

## Compound of Interest

Compound Name: Tyr-Somatostatin-14

Cat. No.: B13390110

[Get Quote](#)

For Researchers, Scientists, and Drug Development Professionals

This technical guide provides a comprehensive overview of the signaling pathways activated by **Tyr-Somatostatin-14**, a key synthetic analog of the endogenous peptide hormone somatostatin. This document details the molecular interactions, downstream signaling cascades, and provides standardized protocols for the experimental investigation of these pathways. The inclusion of quantitative data and visual diagrams is intended to facilitate research and development efforts in fields targeting the somatostatin receptor system.

## Introduction to Tyr-Somatostatin-14 and its Receptors

Somatostatin-14 is a cyclic tetradecapeptide that plays a crucial role in regulating a wide array of physiological processes, including neurotransmission, cell proliferation, and endocrine signaling.[1] **Tyr-Somatostatin-14** is a synthetic derivative of Somatostatin-14, modified with an N-terminal tyrosine residue. This modification is primarily introduced to enable radiolabeling, typically with iodine-125, which is essential for use as a tracer in radioligand binding assays and other quantitative studies.[2]

The biological effects of **Tyr-Somatostatin-14** are mediated through its interaction with a family of five distinct G protein-coupled receptors (GPCRs), designated as somatostatin receptors 1 through 5 (SSTR1, SSTR2, SSTR3, SSTR4, and SSTR5).[1][3] These receptors are expressed in various tissues and are often co-expressed in the same cell, leading to a complex and nuanced signaling response upon ligand binding.

## Core Signaling Pathways of Tyr-Somatostatin-14

Upon binding of **Tyr-Somatostatin-14** to its receptors, a conformational change is induced, leading to the activation of heterotrimeric G proteins. The primary signaling mechanism for all SSTR subtypes involves coupling to pertussis toxin-sensitive inhibitory G proteins (Gi/o).[4] This initiates a cascade of intracellular events that ultimately dictate the cellular response.

## Inhibition of Adenylyl Cyclase and Regulation of cAMP

The canonical signaling pathway activated by **Tyr-Somatostatin-14** across all SSTR subtypes is the inhibition of adenylyl cyclase (AC). The activated  $\alpha$ -subunit of the Gi/o protein directly inhibits AC activity, leading to a decrease in the intracellular concentration of the second messenger cyclic adenosine monophosphate (cAMP). This reduction in cAMP levels subsequently leads to decreased activation of protein kinase A (PKA), thereby modulating the phosphorylation state and activity of numerous downstream target proteins involved in processes such as hormone secretion and cell proliferation.

## Modulation of Ion Channels

**Tyr-Somatostatin-14** signaling also involves the regulation of ion channel activity. The  $\beta\gamma$ -subunits of the activated Gi/o protein can directly interact with and modulate the function of various ion channels. A key effect is the activation of G protein-coupled inwardly rectifying potassium (GIRK) channels, leading to potassium efflux and membrane hyperpolarization. This hyperpolarization makes the cell less excitable and contributes to the inhibitory effects of somatostatin on hormone secretion. Additionally, **Tyr-Somatostatin-14** signaling can lead to the inhibition of voltage-gated calcium channels (VGCCs), reducing calcium influx and further contributing to its inhibitory actions.

## Activation of Phosphotyrosine Phosphatases (PTPs)

Another important signaling arm of the SSTRs is the activation of phosphotyrosine phosphatases (PTPs), such as SHP-1 and SHP-2. Activation of PTPs leads to the dephosphorylation of key signaling molecules, including growth factor receptors and downstream kinases, thereby counteracting proliferative signals. This pathway is a major contributor to the anti-proliferative effects of somatostatin analogs.

## Regulation of the Mitogen-Activated Protein Kinase (MAPK) Pathway

The effect of **Tyr-Somatostatin-14** on the MAPK/ERK pathway is complex and can be either inhibitory or stimulatory depending on the SSTR subtype, cell type, and signaling context. The activation of PTPs can lead to the dephosphorylation and inactivation of components of the MAPK cascade, resulting in an anti-proliferative effect. Conversely, in some cellular contexts, the  $\beta\gamma$ -subunits of Gi/o can lead to the transactivation of receptor tyrosine kinases or activate other signaling intermediates that converge on the MAPK pathway, leading to its activation.

## Phospholipase C (PLC) Activation

While less common than the Gi/o-mediated pathways, some SSTR subtypes, notably SSTR2, have been shown to couple to Gq proteins, leading to the activation of phospholipase C (PLC). Activated PLC cleaves phosphatidylinositol 4,5-bisphosphate (PIP2) into diacylglycerol (DAG) and inositol 1,4,5-trisphosphate (IP3). DAG activates protein kinase C (PKC), while IP3 triggers the release of calcium from intracellular stores, leading to a transient increase in cytosolic calcium levels.

## Quantitative Data on Tyr-Somatostatin-14 Signaling

The following tables summarize the available quantitative data for the interaction of **Tyr-Somatostatin-14** and its parent compound, Somatostatin-14, with the different SSTR subtypes and their downstream signaling effects. Note: Specific quantitative data for **Tyr-Somatostatin-14** is limited. Data for Somatostatin-14 is provided as a close approximation.

Table 1: Receptor Binding Affinities (K<sub>i</sub> in nM)

| Ligand          | SSTR1     | SSTR2      | SSTR3     | SSTR4     | SSTR5      |
|-----------------|-----------|------------|-----------|-----------|------------|
| Somatostatin-14 | 1.3 ± 0.2 | 0.2 ± 0.03 | 0.6 ± 0.1 | 1.0 ± 0.2 | 0.4 ± 0.05 |

Data represents the mean ± SEM of multiple independent experiments. The affinity of **Tyr-Somatostatin-14** is expected to be comparable to Somatostatin-14.

Table 2: Functional Potencies (IC50/EC50 in nM)

| Assay  | SSTR Subtype | Tyr-Somatostatin-14 (or Somatostatin-14) |
|--|--------------|--|
| cAMP Inhibition (IC50)                             | SSTR1-5      | 0.1 - 10                                 |
| ERK1/2 Phosphorylation (EC50)                      | SSTR2, SSTR5 | 1 - 50                                   |
| Intracellular Ca <sup>2+</sup> Mobilization (EC50) | SSTR2        | 5 - 100                                  |

These values are approximate and can vary significantly depending on the cell line and experimental conditions.

## Experimental Protocols

This section provides detailed methodologies for key experiments used to characterize the signaling pathways of **Tyr-Somatostatin-14**.

### Radioligand Binding Assay

Objective: To determine the binding affinity (K<sub>i</sub>) of **Tyr-Somatostatin-14** for each SSTR subtype.

Materials:

- Cell lines stably expressing a single human SSTR subtype (e.g., CHO-K1 or HEK293 cells).

- Membrane preparation buffer: 50 mM Tris-HCl, pH 7.4, 5 mM MgCl<sub>2</sub>, 1 mM EGTA, and protease inhibitors.
- Assay buffer: 50 mM HEPES, pH 7.4, 5 mM MgCl<sub>2</sub>, 1 mM CaCl<sub>2</sub>, 0.2% BSA.
- Radioligand: [<sup>125</sup>I]**Tyr-Somatostatin-14**.
- Non-specific binding control: Unlabeled Somatostatin-14 (1 μM).
- Glass fiber filters (e.g., Whatman GF/C).
- Scintillation counter.

#### Procedure:

- Membrane Preparation:
  1. Culture cells to confluency.
  2. Harvest cells and homogenize in ice-cold membrane preparation buffer.
  3. Centrifuge the homogenate at 500 x g for 10 min at 4°C to remove nuclei and cellular debris.
  4. Centrifuge the supernatant at 40,000 x g for 30 min at 4°C to pellet the membranes.
  5. Resuspend the membrane pellet in assay buffer and determine protein concentration (e.g., using a BCA assay).
- Binding Assay:
  1. In a 96-well plate, add 50 μL of assay buffer, 50 μL of [<sup>125</sup>I]**Tyr-Somatostatin-14** (at a concentration near its K<sub>d</sub>), and 50 μL of competing unlabeled **Tyr-Somatostatin-14** at various concentrations.
  2. For total binding, add 50 μL of assay buffer instead of the competitor. For non-specific binding, add 50 μL of 1 μM unlabeled Somatostatin-14.

3. Initiate the binding reaction by adding 50  $\mu\text{L}$  of the membrane preparation (containing 10-50  $\mu\text{g}$  of protein).
  4. Incubate at 30°C for 60 minutes.
  5. Terminate the assay by rapid filtration through glass fiber filters pre-soaked in 0.5% polyethyleneimine.
  6. Wash the filters three times with ice-cold assay buffer.
  7. Measure the radioactivity retained on the filters using a gamma counter.
- Data Analysis:
    1. Calculate specific binding by subtracting non-specific binding from total binding.
    2. Plot the percentage of specific binding against the logarithm of the competitor concentration.
    3. Determine the IC50 value from the resulting sigmoidal curve using non-linear regression.
    4. Calculate the  $K_i$  value using the Cheng-Prusoff equation:  $K_i = \text{IC}_{50} / (1 + [L]/K_d)$ , where  $[L]$  is the concentration of the radioligand and  $K_d$  is its dissociation constant.

## cAMP Measurement Assay

Objective: To determine the potency (IC50) of **Tyr-Somatostatin-14** in inhibiting adenylyl cyclase activity.

Materials:

- Cells expressing the SSTR of interest.
- Stimulation buffer (e.g., HBSS with 20 mM HEPES, pH 7.4).
- Forskolin (an adenylyl cyclase activator).
- IBMX (a phosphodiesterase inhibitor).

- cAMP assay kit (e.g., HTRF, ELISA, or AlphaScreen).

Procedure:

- Seed cells in a 96-well plate and grow to 80-90% confluency.
- Replace the culture medium with stimulation buffer and pre-incubate for 30 minutes at 37°C.
- Add varying concentrations of **Tyr-Somatostatin-14** to the wells and incubate for 15 minutes.
- Add a fixed concentration of forskolin (e.g., 10  $\mu$ M) to all wells (except the basal control) and incubate for a further 15 minutes.
- Lyse the cells according to the cAMP assay kit manufacturer's instructions.
- Measure the intracellular cAMP levels using the chosen detection method.
- Data Analysis:
  1. Normalize the data to the forskolin-stimulated control.
  2. Plot the percentage of inhibition of the forskolin response against the logarithm of the **Tyr-Somatostatin-14** concentration.
  3. Determine the IC50 value using non-linear regression.

## ERK1/2 Phosphorylation Assay (Western Blot)

Objective: To assess the effect of **Tyr-Somatostatin-14** on the activation of the MAPK/ERK pathway.

Materials:

- Cells expressing the SSTR of interest.
- Serum-free culture medium.
- Lysis buffer (e.g., RIPA buffer with protease and phosphatase inhibitors).

- Primary antibodies: anti-phospho-ERK1/2 (p-ERK) and anti-total-ERK1/2 (t-ERK).
- HRP-conjugated secondary antibody.
- Chemiluminescent substrate.
- Western blotting equipment.

#### Procedure:

- Seed cells and grow to 80-90% confluency.
- Serum-starve the cells for 4-16 hours.
- Treat the cells with varying concentrations of **Tyr-Somatostatin-14** for different time points (e.g., 5, 15, 30 minutes).
- Lyse the cells in ice-cold lysis buffer.
- Determine the protein concentration of the lysates.
- Separate the proteins by SDS-PAGE and transfer them to a PVDF membrane.
- Block the membrane with 5% BSA or non-fat milk in TBST.
- Incubate the membrane with the anti-p-ERK primary antibody overnight at 4°C.
- Wash the membrane and incubate with the HRP-conjugated secondary antibody for 1 hour at room temperature.
- Detect the signal using a chemiluminescent substrate and an imaging system.
- Strip the membrane and re-probe with the anti-t-ERK antibody as a loading control.
- Data Analysis:
  1. Quantify the band intensities for p-ERK and t-ERK.
  2. Normalize the p-ERK signal to the t-ERK signal.

3. Plot the fold change in p-ERK/t-ERK ratio relative to the untreated control against the **Tyr-Somatostatin-14** concentration or time.
4. Determine the EC50 value if a dose-response is observed.

## Visualizing Signaling Pathways and Workflows

The following diagrams, generated using the DOT language for Graphviz, illustrate the core signaling pathways of **Tyr-Somatostatin-14** and a typical experimental workflow.

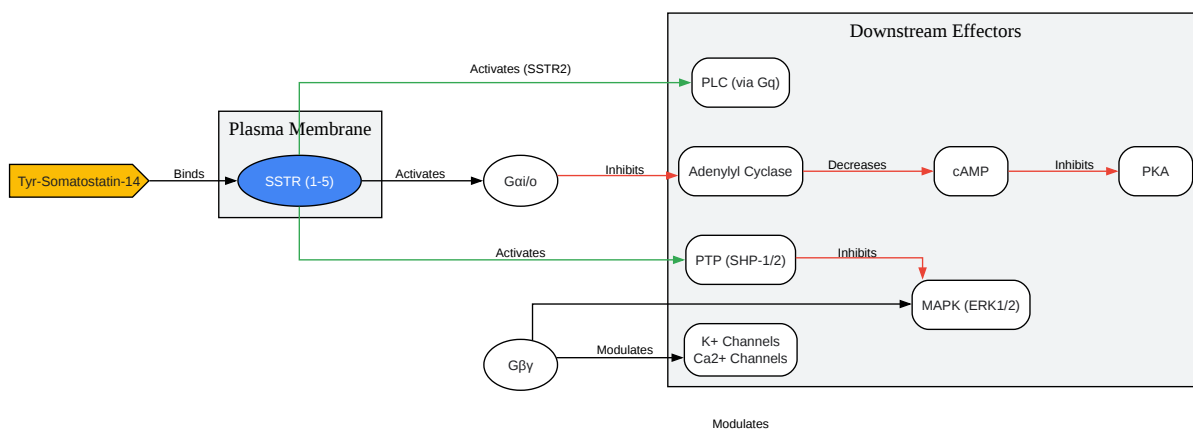

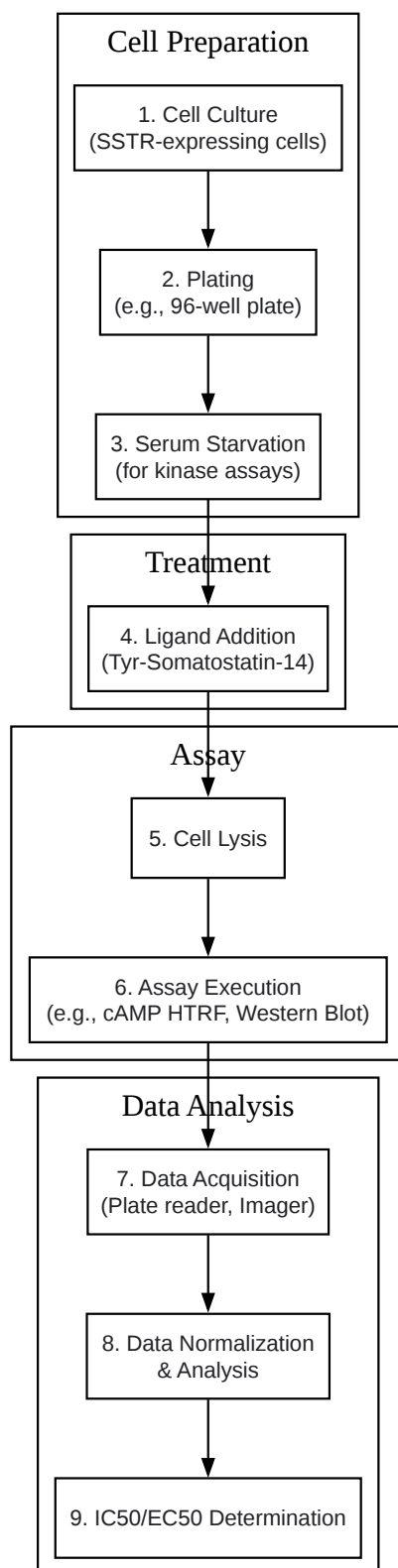

[Click to download full resolution via product page](#)

### Need Custom Synthesis?

BenchChem offers custom synthesis for rare earth carbides and specific isotopic labeling.

Email: [info@benchchem.com](mailto:info@benchchem.com) or [Request Quote Online](#).

## References

- [1. mdpi.com \[mdpi.com\]](https://www.mdpi.com)
- [2. Tyr-Somatostatin-14 Targeting Peptide - Creative Biolabs \[creative-biolabs.com\]](https://www.creative-biolabs.com)
- [3. Somatostatin receptors: from signaling to clinical practice - PubMed \[pubmed.ncbi.nlm.nih.gov\]](https://pubmed.ncbi.nlm.nih.gov)
- [4. Pituitary Somatostatin Receptor Signaling - PMC \[pmc.ncbi.nlm.nih.gov\]](https://pubmed.ncbi.nlm.nih.gov)
- To cite this document: BenchChem. [An In-depth Technical Guide to Tyr-Somatostatin-14 Signaling Pathways]. BenchChem, [2026]. [Online PDF]. Available at: [\[https://www.benchchem.com/product/b13390110/docs#an-in-depth-technical-guide-to-tyr-somatostatin-14-signaling-pathways\]](https://www.benchchem.com/product/b13390110/docs#an-in-depth-technical-guide-to-tyr-somatostatin-14-signaling-pathways)

---

### Disclaimer & Data Validity:

The information provided in this document is for Research Use Only (RUO) and is strictly not intended for diagnostic or therapeutic procedures. While BenchChem strives to provide accurate protocols, we make no warranties, express or implied, regarding the fitness of this product for every specific experimental setup.

**Technical Support:** The protocols provided are for reference purposes. Unsure if this reagent suits your experiment?

**Need Industrial/Bulk Grade?** [Request Custom Synthesis Quote](#)

# BenchChem

Our mission is to be the trusted global source of essential and advanced chemicals, empowering scientists and researchers to drive progress in science and industry.

## Contact

Address: 3281 E Guasti Rd

Ontario, CA 91761, United States

Phone: (601) 213-4426

Email: [info@benchchem.com](mailto:info@benchchem.com)

[Contact our Ph.D. Support Team for a compatibility check](#)