

# Application Notes: Mass Spectrometry Analysis of (3,5-Dimethoxyphenyl)acetic acid ethyl ester

**Author:** BenchChem Technical Support Team. **Date:** December 2025

## Compound of Interest

Compound Name: Ethyl 2-(3,5-dimethoxyphenyl)acetate

Cat. No.: B1339598

[Get Quote](#)

## Introduction

(3,5-Dimethoxyphenyl)acetic acid ethyl ester is an aromatic ester of significant interest in synthetic organic chemistry and serves as a potential building block in the development of pharmaceutical agents. Its structural characterization is crucial for quality control and metabolic studies. Mass spectrometry, coupled with chromatographic techniques such as Gas Chromatography (GC-MS) and Liquid Chromatography (LC-MS), provides a powerful tool for the identification and quantification of this compound. This document outlines the typical mass spectral fragmentation patterns and provides detailed protocols for its analysis.

## Molecular Structure and Properties

- Compound Name: (3,5-Dimethoxyphenyl)acetic acid ethyl ester
- Molecular Formula: C<sub>12</sub>H<sub>16</sub>O<sub>4</sub>
- Molecular Weight: 224.25 g/mol
- Structure:

(Where Ph-(OCH<sub>3</sub>)<sub>2</sub> represents the 3,5-dimethoxyphenyl group)

## Predicted Mass Spectral Fragmentation

While a direct experimental mass spectrum for (3,5-Dimethoxyphenyl)acetic acid ethyl ester is not readily available in public databases, its fragmentation pattern under electron ionization (EI) can be predicted based on the analysis of structurally similar compounds, such as ethyl 3,4-dimethoxyphenyl acetate and methyl 3,5-dimethoxyphenylacetate, and established fragmentation rules for esters and aromatic compounds.[1][2][3]

#### Key Fragmentation Pathways:

- **Molecular Ion Peak ( $M^+$ ):** The molecular ion peak is expected at  $m/z = 224$ . Due to the presence of a stable aromatic ring, this peak should be observable.[4]
- **Loss of the Ethoxy Group ( $-OC_2H_5$ ):** Cleavage of the bond between the carbonyl carbon and the ethoxy group results in the loss of an ethoxy radical, leading to a fragment at  $m/z = 179$ .
- **Loss of the Ethyl Group ( $-C_2H_5$ ):** Fragmentation can occur with the loss of an ethyl radical, yielding a fragment at  $m/z = 195$ .
- **McLafferty Rearrangement:** This is a common fragmentation pathway for esters. It involves the transfer of a gamma-hydrogen to the carbonyl oxygen, followed by the cleavage of the alpha-beta bond, resulting in the elimination of a neutral alkene (ethene in this case) and the formation of a radical cation.
- **Benzylic Cleavage:** The most prominent fragmentation is expected to be the cleavage of the bond between the methylene group and the aromatic ring, leading to the formation of a stable 3,5-dimethoxybenzyl cation at  $m/z = 151$ . This is often the base peak in the spectrum of similar compounds.
- **Tropylium Ion Formation:** The benzyl cation can rearrange to a more stable tropylium ion.
- **Fragments from the Dimethoxy-substituted Ring:** Further fragmentation of the 3,5-dimethoxybenzyl cation can occur through the loss of methyl radicals ( $-CH_3$ ) and formaldehyde ( $-CH_2O$ ) from the methoxy groups.

Table 1: Predicted Mass-to-Charge Ratios ( $m/z$ ) and Corresponding Fragment Ions for (3,5-Dimethoxyphenyl)acetic acid ethyl ester.

m/z	Predicted Fragment Ion	Fragmentation Pathway
224	$[\text{C}_{12}\text{H}_{16}\text{O}_4]^+$	Molecular Ion ( $\text{M}^+$ )
179	$[\text{M} - \text{OC}_2\text{H}_5]^+$	Loss of the ethoxy group
151	$[\text{C}_9\text{H}_{11}\text{O}_2]^+$	Benzylic cleavage (3,5-dimethoxybenzyl cation) - Likely Base Peak
121	$[\text{C}_8\text{H}_9\text{O}]^+$	Loss of formaldehyde from the m/z 151 fragment
91	$[\text{C}_7\text{H}_7]^+$	Tropylium ion from further fragmentation
77	$[\text{C}_6\text{H}_5]^+$	Phenyl cation

## Experimental Protocols

The following are generalized protocols for the analysis of (3,5-Dimethoxyphenyl)acetic acid ethyl ester using GC-MS and LC-MS. These should be optimized based on the specific instrumentation and sample matrix.

### Protocol 1: Gas Chromatography-Mass Spectrometry (GC-MS) Analysis

GC-MS is well-suited for the analysis of volatile and thermally stable compounds like (3,5-Dimethoxyphenyl)acetic acid ethyl ester.

#### 1. Sample Preparation:

- Dissolve a known amount of the sample in a suitable volatile solvent such as ethyl acetate or dichloromethane to a final concentration of approximately 1 mg/mL.
- If the sample is in a complex matrix, a liquid-liquid extraction or solid-phase extraction (SPE) may be necessary to isolate the analyte.[5]

#### 2. GC-MS Instrumentation and Conditions:

- Gas Chromatograph: Agilent 7890B GC or equivalent.[5]

- Mass Spectrometer: Agilent 5977A MSD or equivalent.[5]
- Column: HP-5MS (30 m x 0.25 mm i.d., 0.25 µm film thickness) or equivalent non-polar column.
- Injection Volume: 1 µL.
- Injector Temperature: 250°C.
- Injection Mode: Splitless.
- Carrier Gas: Helium at a constant flow rate of 1 mL/min.
- Oven Temperature Program:
  - Initial temperature: 80°C, hold for 2 minutes.
  - Ramp: Increase to 280°C at a rate of 10°C/min.
  - Hold: Hold at 280°C for 5 minutes.
- MS Transfer Line Temperature: 280°C.
- Ion Source Temperature: 230°C.
- Ionization Mode: Electron Ionization (EI) at 70 eV.
- Mass Range: Scan from m/z 40 to 400.

### 3. Data Analysis:

- Identify the peak corresponding to (3,5-Dimethoxyphenyl)acetic acid ethyl ester based on its retention time.
- Analyze the mass spectrum of the peak and compare the fragmentation pattern with the predicted values in Table 1.
- Use a spectral library (e.g., NIST) to search for similar compounds to aid in identification.

## Protocol 2: Liquid Chromatography-Mass Spectrometry (LC-MS/MS) Analysis

LC-MS is suitable for less volatile compounds or for samples in complex biological or environmental matrices.

### 1. Sample Preparation:

- Dissolve the sample in the mobile phase or a compatible solvent (e.g., acetonitrile/water mixture) to a concentration of approximately 1 µg/mL.
- For complex matrices, perform protein precipitation, liquid-liquid extraction, or solid-phase extraction (SPE) to clean up the sample.[6]
- Filter the final sample solution through a 0.22 µm syringe filter before injection.

## 2. LC-MS/MS Instrumentation and Conditions:

- Liquid Chromatograph: Agilent 1290 Infinity II LC or equivalent.
- Mass Spectrometer: Agilent 6470 Triple Quadrupole LC/MS or equivalent.
- Column: Zorbax Eclipse Plus C18 (100 mm x 2.1 mm, 1.8  $\mu$ m) or equivalent reversed-phase column.
- Mobile Phase A: 0.1% formic acid in water.
- Mobile Phase B: 0.1% formic acid in acetonitrile.
- Gradient Elution:
  - Start with 10% B.
  - Linearly increase to 95% B over 10 minutes.
  - Hold at 95% B for 2 minutes.
  - Return to 10% B and equilibrate for 3 minutes.
- Flow Rate: 0.3 mL/min.
- Column Temperature: 40°C.
- Injection Volume: 5  $\mu$ L.
- Ionization Mode: Electrospray Ionization (ESI), positive mode.
- Ion Source Parameters:
  - Gas Temperature: 300°C.
  - Gas Flow: 5 L/min.
  - Nebulizer: 45 psi.
  - Sheath Gas Temperature: 350°C.
  - Sheath Gas Flow: 11 L/min.
- Capillary Voltage: 3500 V.
- MS/MS Analysis: Use Multiple Reaction Monitoring (MRM) for quantification. Select precursor and product ion transitions based on initial full scan and product ion scan experiments. A potential transition would be the molecular ion  $[M+H]^+$  ( $m/z$  225) to the most stable fragment ion (e.g.,  $m/z$  151).

## 3. Data Analysis:

- Identify the analyte based on its retention time and specific MRM transition.
- For quantification, construct a calibration curve using standards of known concentrations.

## Visualizations

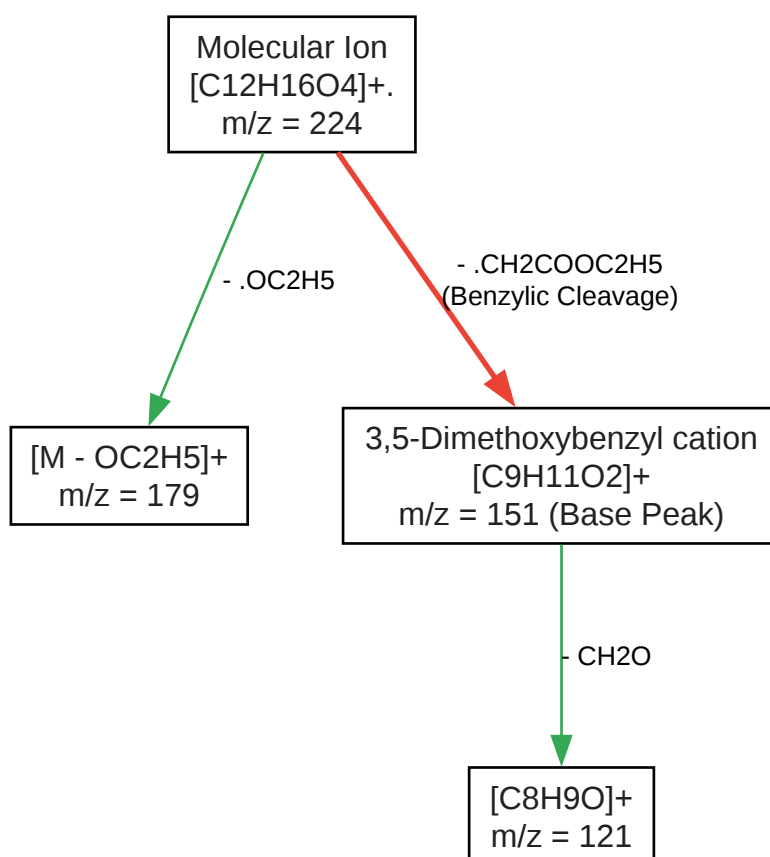
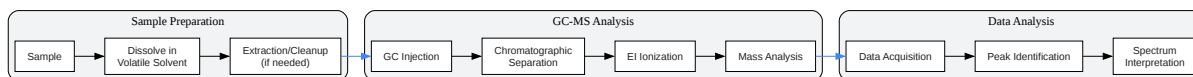

[Click to download full resolution via product page](#)

### Need Custom Synthesis?

BenchChem offers custom synthesis for rare earth carbides and specific isotopic labeling.

Email: [info@benchchem.com](mailto:info@benchchem.com) or [Request Quote Online](#).

## References

- 1. Ethyl 3,4-dimethoxyphenyl acetate [webbook.nist.gov]
- 2. chem.libretexts.org [chem.libretexts.org]

- 3. Acetic acid, 2-(3,5-dimethoxyphenyl)-, methyl ester [webbook.nist.gov]
- 4. youtube.com [youtube.com]
- 5. scispace.com [scispace.com]
- 6. files01.core.ac.uk [files01.core.ac.uk]
- To cite this document: BenchChem. [Application Notes: Mass Spectrometry Analysis of (3,5-Dimethoxyphenyl)acetic acid ethyl ester]. BenchChem, [2025]. [Online PDF]. Available at: [https://www.benchchem.com/product/b1339598#mass-spectrometry-analysis-of-3-5-dimethoxyphenyl-acetic-acid-ethyl-ester]

---

### Disclaimer & Data Validity:

The information provided in this document is for Research Use Only (RUO) and is strictly not intended for diagnostic or therapeutic procedures. While BenchChem strives to provide accurate protocols, we make no warranties, express or implied, regarding the fitness of this product for every specific experimental setup.

**Technical Support:** The protocols provided are for reference purposes. Unsure if this reagent suits your experiment? [[Contact our Ph.D. Support Team for a compatibility check](#)]

**Need Industrial/Bulk Grade?** [Request Custom Synthesis Quote](#)

## BenchChem

Our mission is to be the trusted global source of essential and advanced chemicals, empowering scientists and researchers to drive progress in science and industry.

### Contact

Address: 3281 E Guasti Rd  
Ontario, CA 91761, United States  
Phone: (601) 213-4426  
Email: [info@benchchem.com](mailto:info@benchchem.com)