

Application Note: Chemoselective Reduction of 4-(morpholine-4-carbonyl)benzotrile

Author: BenchChem Technical Support Team. **Date:** May 2026

Compound of Interest

Compound Name: 4-(Morpholine-4-carbonyl)benzotrile

CAS No.: 87294-97-1

Cat. No.: B1339520

[Get Quote](#)

Executive Summary & Chemoselectivity Analysis

The reduction of **4-(morpholine-4-carbonyl)benzotrile** requires careful reagent selection to differentiate between two reducible functionalities: the nitrile and the tertiary amide.

- **Thermodynamic Hierarchy:** In general, nitriles are more easily reduced to primary amines than tertiary amides are reduced to amines. However, strong hydride donors (e.g.,) or unmoderated borane reagents () can reduce both groups, leading to the over-reduced side product 4-(morpholinomethyl)benzylamine.
- **Strategic Pathway:** To obtain the benzylamine derivative (Product A), Catalytic Hydrogenation or Cobalt-Catalyzed Borohydride Reduction are the preferred methods due to their high kinetic selectivity for nitriles. To obtain the aldehyde (Product B), cryogenic DIBAL-H reduction is required.

Reaction Pathway Diagram

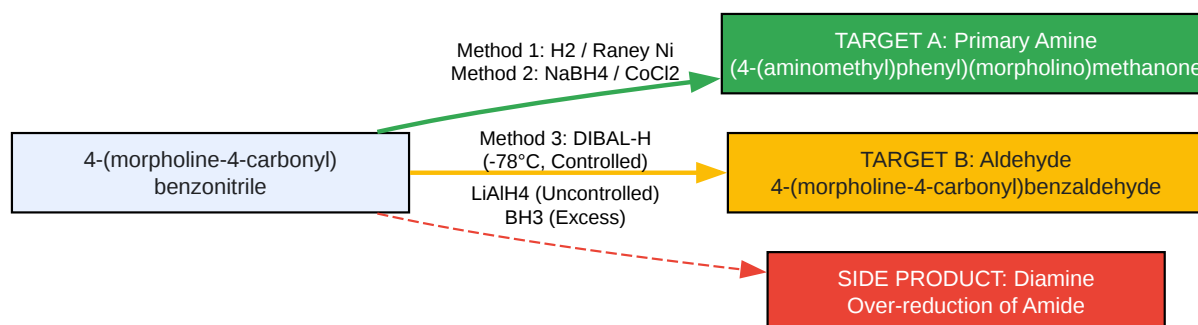

[Click to download full resolution via product page](#)

Figure 1: Chemoselective reduction pathways for **4-(morpholine-4-carbonyl)benzotrile**.

Method A: Catalytic Hydrogenation (Scalable Standard)

Objective: Synthesis of (4-(aminomethyl)phenyl)(morpholino)methanone. Mechanism: Heterogeneous catalysis.[1] Selectivity: Excellent (Amide is inert to under mild conditions).

Materials

- Substrate: **4-(morpholine-4-carbonyl)benzotrile** (1.0 equiv)
- Catalyst: Raney Nickel (Active slurry in water/alcohol) - Pyrophoric!
- Solvent: Methanol (anhydrous)
- Additive: 7N Ammonia in Methanol ()
- Reagent: Hydrogen gas () - Balloon or Parr Shaker

Protocol

- Preparation: In a fume hood, dissolve the substrate (e.g., 10 mmol) in Methanol (50 mL).
- Suppression of Secondary Amines: Add 7N
in MeOH (5 mL).
 - Note: The reduction of nitriles proceeds via an imine intermediate. Without ammonia, the primary amine product can attack the intermediate imine, forming a secondary amine dimer. Excess ammonia shifts the equilibrium toward the primary amine.
- Catalyst Addition: Carefully add Raney Nickel (~20-30 wt% relative to substrate) to the solution.
 - Safety: Raney Nickel is pyrophoric when dry. Always handle as a slurry and keep wet.
- Hydrogenation: Purge the vessel with Nitrogen () x3, then Hydrogen () x3.
 - Pressure:^{[2][3][4][5]} Stir vigorously under a hydrogen balloon (1 atm) or in a Parr shaker at 30-50 psi.
 - Temperature: Ambient temperature (20-25°C).
- Monitoring: Monitor by TLC or LC-MS. Reaction typically completes in 4-12 hours.
 - Endpoint: Disappearance of nitrile peak; appearance of amine mass ().
- Workup: Filter the mixture through a Celite pad to remove the catalyst. Keep the catalyst wet during filtration to prevent ignition. Rinse the pad with MeOH.
- Isolation: Concentrate the filtrate under reduced pressure. The residue is the crude primary amine, often pure enough for the next step. If necessary, purify via flash chromatography

(DCM/MeOH/

).

Method B: Cobalt-Catalyzed Borohydride Reduction (Lab Scale)

Objective: Synthesis of (4-(aminomethyl)phenyl)(morpholino)methanone. Mechanism:

Formation of catalytic Cobalt Boride (

) species in situ. Selectivity: High.[6]

alone does not reduce nitriles or amides rapidly; the Cobalt catalyst activates the nitrile specifically.

Materials

- Substrate: 1.0 equiv
- Reagent: Sodium Borohydride () (2.0 - 4.0 equiv)
- Catalyst: Cobalt(II) Chloride Hexahydrate () (0.5 - 1.0 equiv)
- Solvent: Methanol[7]

Protocol

- Dissolution: Dissolve the substrate (e.g., 5 mmol) and (2.5 mmol) in Methanol (30 mL). The solution will be deep purple/pink.
- Cooling: Cool the solution to 0°C in an ice bath.
- Reduction: Add (15 mmol) portion-wise over 15-20 minutes.

- Observation: The solution will turn black immediately (formation of Cobalt Boride) and evolve hydrogen gas. Vigorous stirring is essential.
- Reaction: Allow the mixture to warm to room temperature and stir for 1-3 hours.
- Quench: Carefully add 1N HCl or saturated solution to quench excess borohydride and dissolve the cobalt salts.
 - Note: If the product is acid-sensitive, use basic workup. However, the amine is basic, so an acidic quench followed by basification (pH > 10) is standard to extract the free amine.
- Extraction: Basify with aqueous NaOH to pH 12. Extract with DCM or EtOAc (x3).
- Drying: Dry organic layers over , filter, and concentrate.

Method C: DIBAL-H Reduction (Aldehyde Synthesis)

Objective: Synthesis of 4-(morpholine-4-carbonyl)benzaldehyde. Mechanism: Hydride transfer to form a stable metallo-imine intermediate, hydrolyzed to aldehyde upon workup. Selectivity: Temperature dependent. At -78°C, DIBAL-H reacts with the nitrile to form an imine-aluminum complex. It can react with the amide, but the nitrile is often kinetically favored or the amide forms a stable tetrahedral intermediate that reverts to amide or cleaves to aldehyde/amine depending on workup. Strict temperature control is critical.

Protocol

- Setup: Flame-dry glassware. Maintain an inert atmosphere (or).
- Dissolution: Dissolve substrate in anhydrous DCM or Toluene. Cool to -78°C (Dry ice/Acetone).

- Addition: Add DIBAL-H (1.0 M in Hexanes/Toluene, 1.1 - 1.2 equiv) dropwise via syringe pump over 30 minutes.
 - Critical: Do not exceed -70°C.
- Stirring: Stir at -78°C for 1-2 hours.
- Quench (Hydrolysis):
 - Add Methanol (excess) at -78°C to quench unreacted hydride.
 - Pour the cold mixture into saturated Rochelle's Salt (Potassium Sodium Tartrate) solution.
- Workup: Vigorously stir the biphasic mixture at room temperature until the emulsion clears (can take 1-4 hours). Separate layers, extract aqueous with DCM, dry, and concentrate.
- Purification: Silica gel chromatography (Hexanes/EtOAc) is usually required to separate the aldehyde from any over-reduced alcohol or unreacted nitrile.

Analytical Validation

Analytical Method	Expected Signal (Product A: Amine)	Expected Signal (Product B: Aldehyde)
1H NMR	New: ppm (s, 2H,) Loss: No aldehyde proton.	New: ppm (s, 1H,)
IR Spectroscopy	Loss: Nitrile stretch () New: N-H stretch ()	Loss: Nitrile stretch New: C=O (Aldehyde) ()
Mass Spectrometry	(net +4H)	(net +1H, +1O, -1N)

References

- Watson, D. et al. "Chemoselective Reduction of Nitriles in the Presence of Amides." *Journal of Organic Chemistry*, 2009, 74(19), 1964–1970. [Link](#)
- Gowda, D. C. et al. "Cobalt-catalyzed reduction of nitriles to amines using sodium borohydride." *Tetrahedron Letters*, 2002, 43(7), 1329-1331. [Link](#)
- Pfizer Inc. "Process for the preparation of Apixaban intermediates." World Intellectual Property Organization, WO2007001385. (Demonstrates morpholine amide stability). [Link](#)
- Organic Chemistry Portal. "Reduction of Nitriles to Amines." (General methodology review). [Link](#)

Need Custom Synthesis?

BenchChem offers custom synthesis for rare earth carbides and specific isotopic labeling.

Email: info@benchchem.com or [Request Quote Online](#).

Sources

- 1. Tuning the selectivity of catalytic nitriles hydrogenation by structure regulation in atomically dispersed Pd catalysts - PMC [[pmc.ncbi.nlm.nih.gov](https://pubmed.ncbi.nlm.nih.gov/)]
- 2. US5124487A - Catalytic reduction of nitriles to aldehydes - Google Patents [patents.google.com]
- 3. Low pressure amide hydrogenation enabled by magnetocatalysis - PMC [[pmc.ncbi.nlm.nih.gov](https://pubmed.ncbi.nlm.nih.gov/)]
- 4. escholarship.org [escholarship.org]
- 5. gousei.f.u-tokyo.ac.jp [gousei.f.u-tokyo.ac.jp]
- 6. pubs.acs.org [pubs.acs.org]
- 7. EP2560964A1 - Process for preparing 4-(4-aminophenyl)morpholin-3-one - Google Patents [patents.google.com]
- To cite this document: BenchChem. [Application Note: Chemoselective Reduction of 4-(morpholine-4-carbonyl)benzotrile]. BenchChem, [2026]. [Online PDF]. Available at: [<https://www.benchchem.com/product/b1339520/docs#application-note-chemoselective-reduction-of-4-morpholine-4-carbonyl-benzotrile>]

Disclaimer & Data Validity:

The information provided in this document is for Research Use Only (RUO) and is strictly not intended for diagnostic or therapeutic procedures. While BenchChem strives to provide accurate protocols, we make no warranties, express or implied, regarding the fitness of this product for every specific experimental setup.

Technical Support: The protocols provided are for reference purposes. Unsure if this reagent suits your experiment?

Need Industrial/Bulk Grade? [Request Custom Synthesis Quote](#)

BenchChem

Our mission is to be the trusted global source of essential and advanced chemicals, empowering scientists and researchers to drive progress in science and industry.

Contact

Address: 3281 E Guasti Rd
Ontario, CA 91761, United States
Phone: (601) 213-4426
Email: info@benchchem.com

[Contact our Ph.D. Support Team for a compatibility check](#)