

# Spectrophotometric Identification of Carmine Red: An In-depth Technical Guide

**Author:** BenchChem Technical Support Team. **Date:** April 2026

## Compound of Interest

Compound Name: Carmine Red

Cat. No.: B13386439

Get Quote

For Researchers, Scientists, and Drug Development Professionals

This guide provides a comprehensive overview of the principles and methodologies for the identification and quantification of **carmine red** dye using UV-Visible spectrophotometry. Carmine, a natural red colorant derived from the insect *Dactylopius coccus*, and its primary coloring principle, carminic acid, are widely used in food, cosmetics, and pharmaceuticals.<sup>[1]</sup> Spectrophotometry offers a rapid, accessible, and reliable method for their analysis.

## Core Principles

The identification of carmine and carminic acid via spectrophotometry is based on their characteristic absorption of light in the visible spectrum. The color of these compounds is highly dependent on pH, which alters the electronic structure of the chromophore and thus its absorption spectrum.<sup>[1][2]</sup> This pH-dependent shift in the maximum absorption wavelength ( $\lambda_{max}$ ) is a key feature used for identification and differentiation from other colorants. Carminic acid, an anthraquinone derivative, exhibits distinct spectral properties from carmine, which is a hydrated aluminum chelate of carminic acid.<sup>[2][3]</sup>

## Quantitative Data Summary

The following tables summarize the key spectrophotometric data for carmine and carminic acid under different pH conditions. This data is essential for the identification and quantification of the dyes.

Table 1: Absorption Maxima ( $\lambda_{max}$ ) of Carmine and Carminic Acid at Different pH Values

Compound	pH	Wavelength ( $\lambda_{max}$ )	Observations
Carminic Acid	1.9 - 2.1	490 - 500 nm	Orange-red color
Carminic Acid	6.0	~530 nm	Red color[2]
Carminic Acid	12.5 - 12.6	565 - 570 nm	Main peak, with a strong secondary peak ~40 nm lower[4][5]
Carmine	12.5 - 12.6	530 - 535 nm	Main peak, with a secondary peak or shoulder ~30 nm higher[4][5][6]
4-Aminocarminic Acid	1.9 - 2.1	525 - 530 nm	An acid-stable derivative[6]
4-Aminocarminic Acid	12.5 - 12.6	570 - 575 nm	Major peak, with a shoulder or weak secondary peak ~40 nm lower[4]

Table 2: Spectrophotometric Assay Parameters

Parameter	Value	Conditions	Reference
Absorbance of 100 mg/L Carminic Acid Solution	1.39	At ~494 nm	[3]
Absorbance Range for 100 mg/L Carmine Solution	1.2 - 1.8	At 530-535 nm, pH 12.5-12.6	[6]
Molar Extinction Coefficient of Carminic Acid	8595	At 490 nm in 0.02 M aqueous HCl	[7]

## Experimental Protocols

The following protocols provide detailed methodologies for the spectrophotometric analysis of **carmine red**.

### Preparation of Standard Solutions

Objective: To prepare stock and working standard solutions of carminic acid or carmine for calibration and identification.

Materials:

- Carminic acid or carmine reference standard
- Distilled or deionized water
- Hydrochloric acid (HCl)
- Sodium hydroxide (NaOH)
- Volumetric flasks (100 mL, 1000 mL)
- Analytical balance

Procedure:

- Stock Solution (e.g., 100 mg/L): Accurately weigh 10 mg of the reference standard and transfer it to a 100 mL volumetric flask. Dissolve in a small amount of distilled water and then dilute to the mark with distilled water. Mix thoroughly.
- Working Solutions: Prepare a series of working solutions by diluting the stock solution with the appropriate solvent (e.g., 0.01 M HCl or a buffer of a specific pH) to achieve the desired concentrations for creating a calibration curve.

## Sample Preparation

Objective: To extract **carmine red** from a sample matrix (e.g., food, pharmaceutical tablet) and prepare it for spectrophotometric analysis.

### A. Aqueous Extraction from Solid Samples (e.g., Cochineal Insects):

- Grind the sample to a fine powder using a mortar and pestle.[8]
- Weigh a specific amount of the powdered sample (e.g., 0.25 g) and transfer it to a beaker.[3][8]
- Add a known volume of extraction solvent (e.g., 100 mL of distilled water).[3][8]
- Heat the mixture to boiling for a defined period (e.g., 15-20 minutes) to facilitate extraction.[8][9]
- Allow the solution to cool and then filter to remove solid particles.[8][9]
- The filtrate can then be diluted as necessary for analysis.

### B. Extraction from Beverages or Pharmaceutical Tablets:

- For beverages, a simple dilution with the appropriate buffer may be sufficient.
- For tablets, crush the tablet into a fine powder.[10]
- Dissolve the powder in a known volume of solvent (e.g., 0.01 M NaOH).[11]
- If necessary, use solid-phase extraction (SPE) for sample clean-up and concentration.[11]

## Spectrophotometric Measurement

Objective: To measure the absorbance spectrum of the prepared solutions and identify the  $\lambda_{\text{max}}$ .

Equipment:

- UV-Visible Spectrophotometer
- Quartz or glass cuvettes (1 cm path length)

Procedure:

- Turn on the spectrophotometer and allow it to stabilize for at least 15 minutes.[9]
- Set the desired wavelength range for the scan (e.g., 350-700 nm).
- Blanking: Fill a cuvette with the same solvent used to prepare the sample and working solutions (the "blank"). Place it in the spectrophotometer and zero the absorbance (or set transmittance to 100%).[9]
- Measurement: Rinse the cuvette with the sample or standard solution, then fill it and place it in the spectrophotometer.
- Record the absorbance spectrum.
- Identify the wavelength of maximum absorbance ( $\lambda_{\text{max}}$ ).

## pH-Dependent Analysis for Identification

Objective: To confirm the identity of the dye by observing the characteristic spectral shift with pH changes.[12]

Procedure:

- Prepare two aliquots of the sample solution.
- Acidic Condition: Adjust the pH of the first aliquot to approximately 1.9 - 2.1 using a dilute solution of HCl. Scan the spectrum and determine the  $\lambda_{\text{max}}$ . [5][6]

- Alkaline Condition: Adjust the pH of the second aliquot to approximately 12.5 - 12.6 using a dilute solution of NaOH. Scan the spectrum and determine the  $\lambda_{\text{max}}$ .[\[5\]](#)[\[6\]](#)
- Compare the observed  $\lambda_{\text{max}}$  values at both high and low pH with the reference data in Table 1 to identify the dye as carmine or carminic acid.[\[12\]](#)

## Visualizations

### Chemical Structure of Carminic Acid

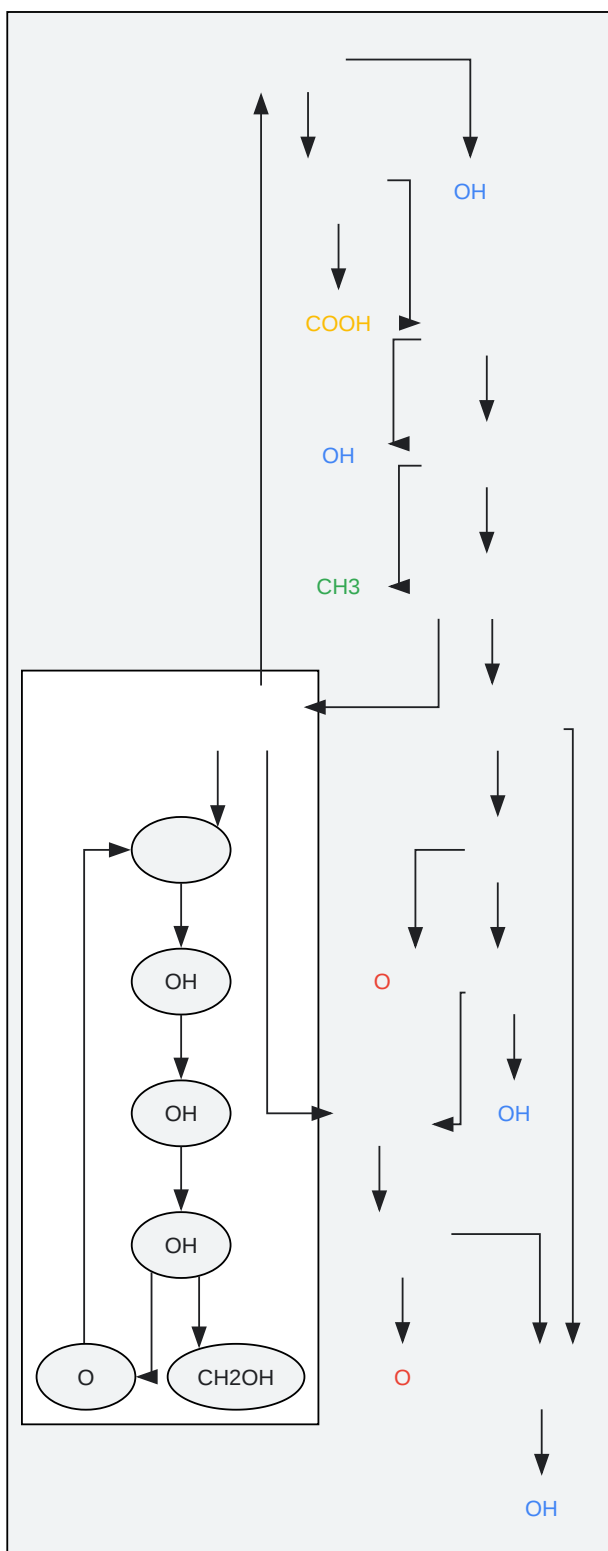

Figure 1: Chemical Structure of Carminic Acid.

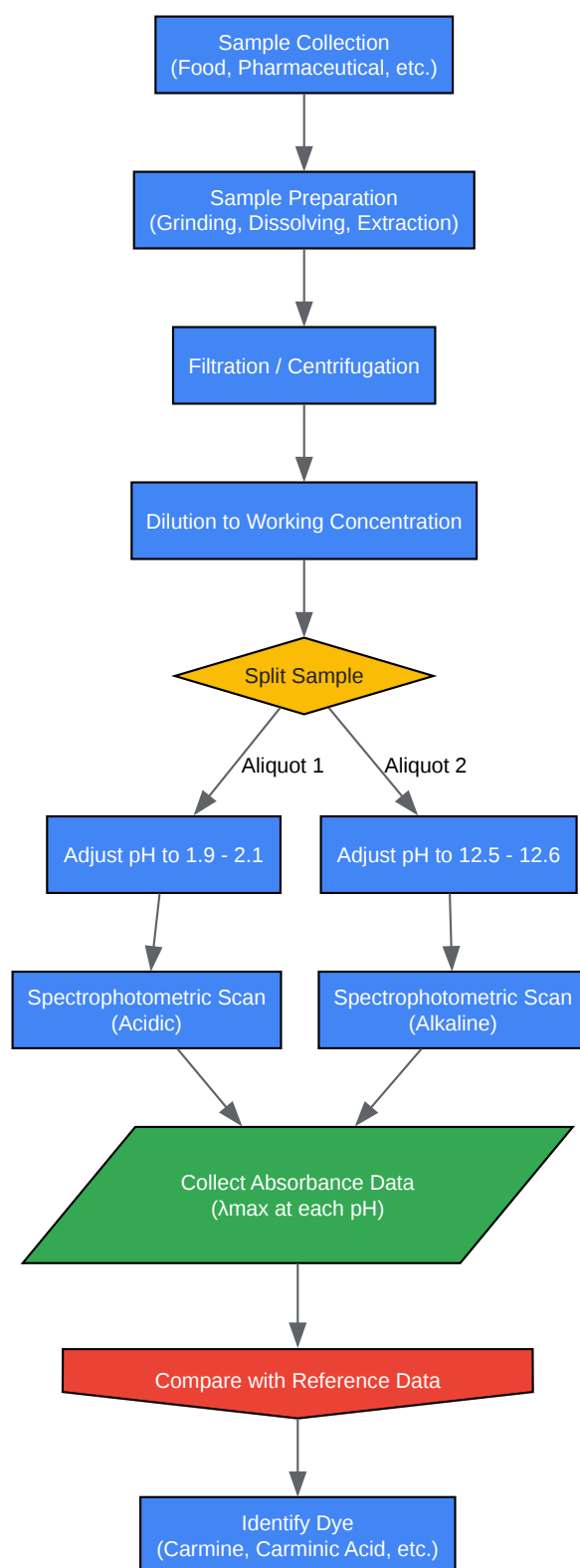

Figure 2: Workflow for Spectrophotometric Dye Identification.

[Click to download full resolution via product page](#)

### Need Custom Synthesis?

BenchChem offers custom synthesis for rare earth carbides and specific isotopic labeling.

Email: [info@benchchem.com](mailto:info@benchchem.com) or [Request Quote Online](#).

## References

- [1. mdpi.com \[mdpi.com\]](https://www.mdpi.com)
- [2. Effects of different food ingredients on the color and absorption spectrum of carminic acid and carminic aluminum lake - PMC \[pmc.ncbi.nlm.nih.gov\]](#)
- [3. fao.org \[fao.org\]](https://www.fao.org)
- [4. researchgate.net \[researchgate.net\]](https://www.researchgate.net)
- [5. researchgate.net \[researchgate.net\]](https://www.researchgate.net)
- [6. Revised procedures for the certification of carmine \(C.I. 75470, Natural red 4\) as a biological stain - PubMed \[pubmed.ncbi.nlm.nih.gov\]](#)
- [7. A simple assay procedure for carmine and carminic acid samples. | Semantic Scholar \[semanticscholar.org\]](#)
- [8. uiw.edu \[uiw.edu\]](https://www.uiw.edu)
- [9. scribd.com \[scribd.com\]](https://www.scribd.com)
- [10. documents.thermofisher.com \[documents.thermofisher.com\]](https://documents.thermofisher.com)
- [11. proakademia.eu \[proakademia.eu\]](https://www.proakademia.eu)
- [12. A method for determining identity and relative purity of carmine, carminic acid and aminocarminic acid - PubMed \[pubmed.ncbi.nlm.nih.gov\]](#)
- To cite this document: BenchChem. [Spectrophotometric Identification of Carmine Red: An In-depth Technical Guide]. BenchChem, [2026]. [Online PDF]. Available at: [\[https://www.benchchem.com/product/b13386439/docs#spectrophotometric-identification-of-carmine-red-an-in-depth-technical-guide\]](https://www.benchchem.com/product/b13386439/docs#spectrophotometric-identification-of-carmine-red-an-in-depth-technical-guide)

---

### Disclaimer & Data Validity:

The information provided in this document is for Research Use Only (RUO) and is strictly not intended for diagnostic or therapeutic procedures. While BenchChem strives to provide

accurate protocols, we make no warranties, express or implied, regarding the fitness of this product for every specific experimental setup.

**Technical Support:** The protocols provided are for reference purposes. Unsure if this reagent suits your experiment?

**Need Industrial/Bulk Grade?** [Request Custom Synthesis Quote](#)

## BenchChem

Our mission is to be the trusted global source of essential and advanced chemicals, empowering scientists and researchers to drive progress in science and industry.

### Contact

Address: 3281 E Guasti Rd

Ontario, CA 91761, United States

Phone: (601) 213-4426

Email: [info@benchchem.com](mailto:info@benchchem.com)

[Contact our Ph.D. Support Team for a compatibility check](#)