

Application Notes and Protocols for BrettPhos Palladacycle G3

Author: BenchChem Technical Support Team. **Date:** May 2026

Compound of Interest

Compound Name: *BrettPhos Palladacycle*

Cat. No.: *B13385344*

[Get Quote](#)

Introduction: The Power of Third-Generation Palladacycle Precatalysts

In the landscape of modern synthetic chemistry, palladium-catalyzed cross-coupling reactions are indispensable tools for the construction of carbon-carbon and carbon-heteroatom bonds.^[1] The evolution of catalyst systems has been driven by the need for greater efficiency, broader substrate scope, and operational simplicity. **BrettPhos Palladacycle G3**, a third-generation (G3) Buchwald precatalyst, represents a significant advancement in this field.^{[2][3]}

Unlike earlier palladium sources that can be sensitive to air and moisture, G3 precatalysts are robust, thermally-stable solids that are easy to handle and weigh in a standard laboratory environment.^[4] Their key advantage lies in the reliable and rapid generation of the active, monoligated LPd(0) catalytic species under mild conditions, which is often crucial for the success of challenging transformations.^{[4][5][6]} This feature allows for lower catalyst loadings, shorter reaction times, and a high degree of reproducibility.^{[2][6]} These attributes make BrettPhos Pd G3 an exceptional choice for a wide array of cross-coupling reactions, including the Buchwald-Hartwig amination, Suzuki-Miyaura coupling, and C-O bond formation.^[5]

This guide provides a comprehensive overview of the general procedures for using BrettPhos Pd G3, covering its activation mechanism, detailed experimental protocols, and expert troubleshooting advice to empower researchers in their synthetic endeavors.

Mechanism: Activating the Precatalyst

The "precatalyst" designation signifies that BrettPhos Pd G3 is a stable Pd(II) complex that must be reduced in situ to the catalytically active Pd(0) state. The G3 architecture is ingeniously designed for this transformation.^[5] The activation is typically initiated by a base, which deprotonates the amine on the 2-aminobiphenyl scaffold.^[4] This triggers a C-N reductive elimination, releasing the active LPd(0) species, a methanesulfonate salt, and a carbazole byproduct.^{[5][7]}

The replacement of the chloride ligand (found in G2 precatalysts) with a more electron-withdrawing and non-coordinating methanesulfonate (OMs) group in G3 precatalysts facilitates this activation and enhances the catalyst's stability in solution.^{[4][5]} The quantitative and rapid formation of the active catalyst under mild conditions is a primary reason for the superior performance of G3 systems.^[5]

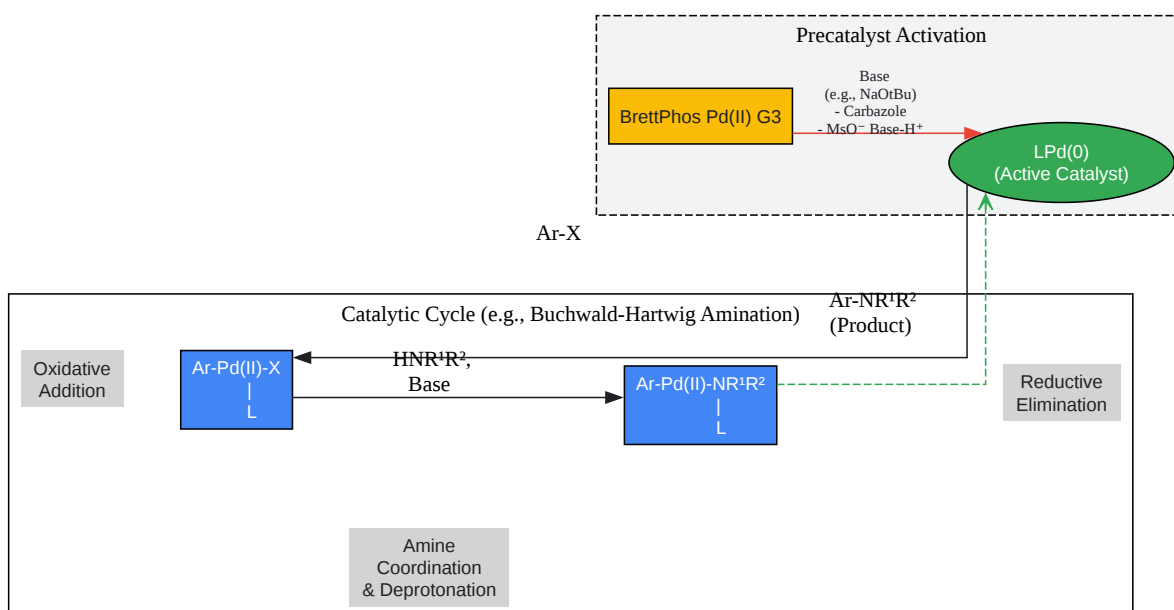

[Click to download full resolution via product page](#)

Figure 1: Activation of BrettPhos Pd G3 and the subsequent catalytic cycle.

Safety and Handling

While BrettPhos Pd G3 is designed for stability, standard laboratory safety practices are essential.

- Personal Protective Equipment (PPE): Always wear safety glasses, a lab coat, and appropriate gloves when handling the catalyst and associated reagents.
- Handling: Handle the solid catalyst in a well-ventilated area or a fume hood. Avoid inhalation of dust.[8] Some safety data sheets indicate it may cause skin and eye irritation.[8]

- Storage: Store the catalyst in a tightly sealed container under an inert atmosphere (nitrogen or argon) at 2–8 °C for long-term stability.[3][9]
- Inert Atmosphere for Reactions: While the solid is air-stable, the active Pd(0) species generated in solution is sensitive to oxygen. Therefore, all cross-coupling reactions must be set up and run under an inert atmosphere (e.g., nitrogen or argon).[10]

General Experimental Protocol: A Representative Cross-Coupling Reaction

This protocol provides a robust starting point for a typical Buchwald-Hartwig amination reaction. It can be adapted for other cross-couplings by modifying the coupling partners and, in some cases, the base or solvent.

Materials and Reagents:

- Aryl Halide (e.g., Aryl Bromide or Chloride), 1.0 mmol
- Amine, 1.2 mmol
- Base (e.g., Sodium tert-butoxide, NaOtBu), 1.4 mmol
- BrettPhos Pd G3, 0.01–0.02 mmol (1–2 mol%)
- Anhydrous, degassed solvent (e.g., Toluene or Dioxane), 2–4 mL
- Oven-dried reaction vessel (e.g., Schlenk tube or vial with a PTFE-lined cap)
- Magnetic stir bar

Reaction Setup (Performed in a Glovebox or using Schlenk Technique):

- Vessel Preparation: To an oven-dried reaction vessel containing a magnetic stir bar, add the BrettPhos Pd G3 precatalyst (1-2 mol%), the solid base (e.g., NaOtBu, 1.4 equiv), and the solid aryl halide (if applicable, 1.0 equiv).

- Causality Note: Adding the solid components first under an inert atmosphere prevents premature degradation of the catalyst once the solvent is introduced.
- Seal and Purge: Seal the vessel with a rubber septum or a PTFE-lined screw cap. If not in a glovebox, evacuate the vessel and backfill with an inert gas (argon or nitrogen). Repeat this cycle three times to ensure a completely inert atmosphere.
- Reagent Addition: Through the septum, add the anhydrous, degassed solvent (e.g., toluene, 2-4 mL) via syringe.
- Liquid Reagent Addition: Add the liquid amine (1.2 equiv) and the liquid aryl halide (if applicable) via syringe.
 - Causality Note: The order of addition can sometimes be important. It is common practice to add the solvent and liquid reagents after the solids are under an inert atmosphere.

Reaction Execution:

- Heating and Stirring: Place the sealed reaction vessel in a preheated oil bath or heating block set to the desired temperature (typically 80–110 °C for aryl chlorides). Stir the mixture vigorously for the duration of the reaction.[\[11\]](#)[\[12\]](#)
- Monitoring: Monitor the reaction progress by periodically taking small aliquots (via syringe) and analyzing them by TLC, GC-MS, or LC-MS.

Workup and Purification:

- Cooling and Quenching: Once the reaction is complete, cool the mixture to room temperature. Carefully quench the reaction by adding water or a saturated aqueous solution of ammonium chloride.
- Extraction: Transfer the mixture to a separatory funnel and extract the product with an appropriate organic solvent (e.g., ethyl acetate or dichloromethane). Wash the combined organic layers with brine, dry over anhydrous sodium sulfate or magnesium sulfate, and filter.
- Purification: Concentrate the filtrate under reduced pressure. Purify the crude product by flash column chromatography on silica gel to obtain the desired compound.

Data Presentation: Recommended Reaction Parameters

The optimal conditions can vary based on the specific substrates. The following tables provide general guidelines for starting points.

Table 1: Typical Conditions for Buchwald-Hartwig Amination

Parameter	Recommendation	Rationale & Notes
Catalyst Loading	0.5 - 2 mol%	G3 precatalysts are highly active; lower loadings are often sufficient.[13] For challenging substrates, loading can be increased.
Base	NaOtBu, K ₃ PO ₄ , Cs ₂ CO ₃	Strong, non-nucleophilic bases are preferred. NaOtBu is common for amines; weaker carbonates are used for more sensitive substrates.[12][14]
Solvent	Toluene, Dioxane, THF	Anhydrous and oxygen-free solvents are critical. Toluene is a versatile choice for many couplings.[11]
Temperature	80 - 110 °C	Higher temperatures are often needed for less reactive aryl chlorides. Aryl bromides and iodides may react at lower temperatures.

| Time | 2 - 24 hours | Reaction times are highly substrate-dependent. Monitor for completion to avoid degradation. |

Table 2: Versatility in Cross-Coupling Reactions

Reaction Type	Typical Coupling Partners	Recommended Base
Suzuki-Miyaura	Aryl Halide + Boronic Acid/Ester	K_3PO_4 , K_2CO_3 [15]
C-O Coupling	Aryl Halide + Alcohol/Phenol	CS_2CO_3 , K_3PO_4 [5][14]
Heck Reaction	Aryl Halide + Alkene	Et_3N , K_2CO_3

| Negishi Coupling | Aryl Halide + Organozinc Reagent | No strong base required |

Troubleshooting Common Issues

Even with a robust catalyst, challenges can arise. A systematic approach is key to resolving them.[10]

Figure 2: A logical workflow for troubleshooting cross-coupling reactions.

Table 3: Common Problems and Solutions

Problem	Potential Cause(s)	Suggested Solution(s)
Low or No Product Yield	1. Inefficient catalyst activation.[10] 2. Impure/wet reagents or solvent. 3. Insufficiently inert atmosphere.	1. Ensure the base is fresh and sufficiently strong. 2. Use freshly purified substrates and anhydrous, degassed solvents.[10] 3. Improve Schlenk technique or use a glovebox.
Sluggish or Stalled Reaction	1. Reaction temperature is too low. 2. Sterically hindered substrates. 3. Catalyst deactivation.	1. Increase the temperature in 10-20 °C increments.[12] 2. Increase catalyst loading and/or reaction time. 3. Ensure the atmosphere is strictly inert; oxygen can degrade the active catalyst.

| Formation of Side Products | 1. Homocoupling of boronic acids (Suzuki).[16] 2. Hydrodehalogenation of aryl halide. 3. Competitive reactions (e.g., arylation of solvent). | 1. Ensure the reaction is well-degassed; oxygen promotes homocoupling.[16] 2. This can indicate issues with the catalytic cycle; screen different bases or solvents. 3. Consider a more inert solvent if side-reactivity is observed. |

References

- BenchChem. (2025).
- Scott, N., et al. (2025). Catalyst Activation and Speciation Involving DyadPalladate Precatalysts in Suzuki–Miyaura and Buchwald–Hartwig Cross-Couplings. *Organometallics*. [\[Link\]](#)
- Scott, N., et al. (2025). Catalyst Activation and Speciation Involving DyadPalladate Precatalysts in Suzuki–Miyaura and Buchwald–Hartwig Cross-Couplings. PMC - NIH. [\[Link\]](#)
- Scott, N., et al. (2025). Catalyst Activation and Speciation Involving DyadPalladate™ Pre-Catalysts in Suzuki-Miyaura and Buchwald-Hartwig Cross-Couplings. York Research Database. [\[Link\]](#)
- ResearchGate. (n.d.). The three main pathways of precatalyst activation proposed for allyl-type precatalysts. [\[Link\]](#)
- ResearchGate. (n.d.). (PDF) Toward prediction of the precatalyst activation mechanism through the cross-coupling reactions: Reduction of Pd(II) to Pd(0) in precatalyst of the type Pd-PEPPSI. [\[Link\]](#)
- American Chemical Society. (2020). Synthesis of Fluorinated Alkyl Aryl Ethers by Palladium-Catalyzed C–O Cross-Coupling. [\[Link\]](#)
- ResearchGate. (2020). Synthesis of Fluorinated Alkyl Aryl Ethers by Palladium-Catalyzed C–O Cross-Coupling. [\[Link\]](#)
- Bruno, N. C., et al. (2013). Design and Preparation of New Palladium Precatalysts for C-C and C-N Cross-Coupling Reactions. PMC - NIH. [\[Link\]](#)

- Reichert, E. C. (2019). Development of Deactivation-Resistant Catalysts for Pd-Catalyzed C–N Cross-Coupling Reactions. DSpace@MIT. [[Link](#)]
- Scientific Laboratory Supplies. (n.d.). BrettPhos Pd G3, 95%. [[Link](#)]
- Johnson Matthey. (n.d.). BPC-304: BrettPhos Gen 3 | CAS 1470372-59-8. [[Link](#)]
- Fantoni, T., et al. (2025). Mastering palladium-catalyzed cross-coupling reactions: the critical role of in situ pre-catalyst reduction design. Organic Chemistry Frontiers. [[Link](#)]
- Yoneda Labs. (n.d.). Suzuki-Miyaura cross-coupling: Practical Guide. [[Link](#)]
- Chemistry LibreTexts. (2023). 2.2: Pd-Catalyzed Cross Coupling Reactions. [[Link](#)]
- The Organic Chemistry Tutor. (2025). The Ultimate Guide to Buchwald-Hartwig Amination: Synthesize C–N Bonds! [Video]. YouTube. [[Link](#)]
- PubMed. (2017). Controllable Activation of Pd-G3 Palladacycle Precatalyst in the Presence of Thiosugars: Rapid Access to 1-Aminobiphenyl Thioglycoside Atropoisomers at Room Temperature. [[Link](#)]
- ResearchGate. (2025). Buchwald-Hartwig Aminations of Aryl Chlorides: A Practical Protocol Based on Commercially Available Pd(0)NHC Catalysts. [[Link](#)]

Need Custom Synthesis?

BenchChem offers custom synthesis for rare earth carbides and specific isotopic labeling.

Email: info@benchchem.com or [Request Quote Online](#).

Sources

- 1. chem.libretexts.org [chem.libretexts.org]
- 2. scientificlabs.co.uk [scientificlabs.co.uk]
- 3. [BrettPhos Pd G3 | 1470372-59-8](https://chemicalbook.com) [chemicalbook.com]
- 4. sigmaaldrich-jp.com [sigmaaldrich-jp.com]

- [5. G3 and G4 Buchwald Precatalysts \[sigmaaldrich.com\]](#)
- [6. BPC 304: BrettPhos Gen 3 | CAS 1470372 59 8 | Johnson Matthey \[matthey.com\]](#)
- [7. pdf.benchchem.com \[pdf.benchchem.com\]](#)
- [8. colonialmetals.com \[colonialmetals.com\]](#)
- [9. chemscene.com \[chemscene.com\]](#)
- [10. pdf.benchchem.com \[pdf.benchchem.com\]](#)
- [11. pdf.benchchem.com \[pdf.benchchem.com\]](#)
- [12. sigmaaldrich.com \[sigmaaldrich.com\]](#)
- [13. Buy tBuBrettPhos Pd G3 | 1536473-72-9 \[smolecule.com\]](#)
- [14. pubs.acs.org \[pubs.acs.org\]](#)
- [15. Design and Preparation of New Palladium Precatalysts for C-C and C-N Cross-Coupling Reactions - PMC \[pmc.ncbi.nlm.nih.gov\]](#)
- [16. Yoneda Labs \[yonedalabs.com\]](#)
- To cite this document: BenchChem. [Application Notes and Protocols for BrettPhos Palladacycle G3]. BenchChem, [2026]. [Online PDF]. Available at: [\[https://www.benchchem.com/product/b13385344/docs#application-notes-and-protocols-for-brettphos-palladacycle-g3\]](https://www.benchchem.com/product/b13385344/docs#application-notes-and-protocols-for-brettphos-palladacycle-g3)

Disclaimer & Data Validity:

The information provided in this document is for Research Use Only (RUO) and is strictly not intended for diagnostic or therapeutic procedures. While BenchChem strives to provide accurate protocols, we make no warranties, express or implied, regarding the fitness of this product for every specific experimental setup.

Technical Support: The protocols provided are for reference purposes. Unsure if this reagent suits your experiment?

Need Industrial/Bulk Grade? [Request Custom Synthesis Quote](#)

BenchChem

Our mission is to be the trusted global source of essential and advanced chemicals, empowering scientists and researchers to drive progress in science and industry.

Contact

Address: 3281 E Guasti Rd
Ontario, CA 91761, United States
Phone: (601) 213-4426
Email: info@benchchem.com

[Contact our Ph.D. Support Team for a compatibility check](#)