

# Preliminary In Vitro Studies on Bakkenolide Bioactivity: A Technical Guide

**Author:** BenchChem Technical Support Team. **Date:** April 2026

## Compound of Interest

Compound Name: *Bakkenolide D*

Cat. No.: *B13384392*

[Get Quote](#)

Disclaimer: This technical guide summarizes the preliminary in vitro bioactivity of bakkenolides, focusing on Bakkenolide B and Bakkenolide-IIIa as representative compounds of this class. Due to a lack of extensive in vitro research specifically on **Bakkenolide D**, the data and experimental protocols presented herein are derived from studies on these closely related and well-researched analogs. The findings are intended to provide insights into the potential bioactivity of **Bakkenolide D** for researchers, scientists, and drug development professionals.

## Introduction

Bakkenolides are a class of sesquiterpene lactones isolated from various plant species, notably from the genus *Petasites*. Preliminary in vitro studies have highlighted their potential therapeutic effects, particularly in the areas of neuroprotection and anti-inflammation. This document provides a comprehensive overview of the in vitro bioactivity of key bakkenolides, detailing the experimental methodologies and summarizing the quantitative findings from seminal studies. The focus is on the cellular and molecular mechanisms underlying their observed effects, with a particular emphasis on key signaling pathways such as NF- $\kappa$ B and MAPK.

## Neuroprotective Effects of Bakkenolide-IIIa

In vitro studies on Bakkenolide-IIIa have demonstrated its significant neuroprotective properties in models of cerebral ischemia. The primary model utilized is the oxygen-glucose deprivation (OGD) model in primary cultured hippocampal neurons, which simulates ischemic conditions in vitro.

Cell Line/Model	Treatment	Concentration(s)	Key Findings	Reference
Primary Hippocampal Neurons	Oxygen-Glucose Deprivation (OGD)	1, 10, 100 ng/mL	Increased cell viability and decreased apoptosis in a dose-dependent manner.	[1]
Primary Hippocampal Neurons	Oxygen-Glucose Deprivation (OGD)	1, 10, 100 ng/mL	Dose-dependently increased the ratio of Bcl-2 to Bax.	[1]
Primary Hippocampal Neurons	Oxygen-Glucose Deprivation (OGD)	1, 10, 100 ng/mL	Inhibited the phosphorylation of Akt, ERK1/2, IKK $\beta$ , I $\kappa$ B $\alpha$ , and p65.	[1]

### 2.2.1. Primary Hippocampal Neuron Culture and Oxygen-Glucose Deprivation (OGD) Model

Primary hippocampal neurons were cultured from neonatal Sprague-Dawley rats.[1] The OGD model was induced by replacing the normal culture medium with a glucose-free medium and incubating the cells in a hypoxic chamber.[1] Following the OGD period, the cells were returned to normal culture conditions to simulate reperfusion.[1]

### 2.2.2. Cell Viability and Apoptosis Assays

Cell viability was assessed using the MTT assay.[1] The number of apoptotic neurons was determined using the TUNEL (Terminal deoxynucleotidyl transferase dUTP nick end labeling)

assay.[1]

### 2.2.3. Western Blot Analysis

The expression levels of Bcl-2, Bax, and the phosphorylation status of Akt, ERK1/2, IKK $\beta$ , I $\kappa$ B $\alpha$ , and p65 were determined by Western blot analysis.[1]

Bakkenolide-IIIa exerts its neuroprotective effects by inhibiting the NF- $\kappa$ B signaling pathway.[1] Under ischemic conditions (OGD), the phosphorylation of Akt and ERK1/2 is increased, leading to the activation of the IKK complex. This, in turn, phosphorylates I $\kappa$ B $\alpha$ , leading to its degradation and the subsequent translocation of the p65 subunit of NF- $\kappa$ B to the nucleus, where it promotes the transcription of pro-apoptotic genes. Bakkenolide-IIIa was shown to inhibit the phosphorylation of Akt, ERK1/2, IKK $\beta$ , I $\kappa$ B $\alpha$ , and p65, thereby preventing the nuclear translocation of NF- $\kappa$ B and subsequent apoptosis.[1]

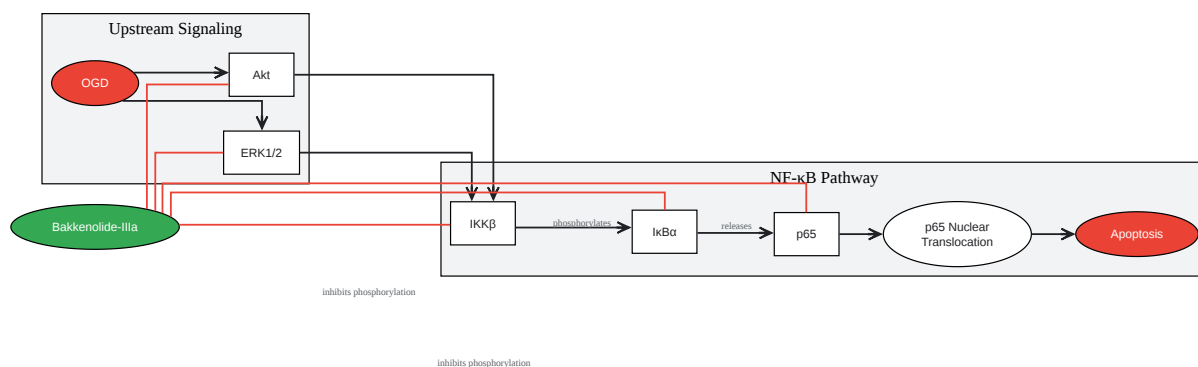

[Click to download full resolution via product page](#)

Caption: Bakkenolide-IIIa Neuroprotective Signaling Pathway.

## Anti-inflammatory and Anti-allergic Effects of Bakkenolide B

In vitro studies have demonstrated the potent anti-inflammatory and anti-allergic properties of Bakkenolide B. These effects have been primarily investigated in mast cells and macrophages.

Cell Line	Treatment	Concentration(s)	Key Findings	Reference
RBL-2H3 Mast Cells	Antigen-induced degranulation	1, 3, 10 $\mu$ M	Concentration-dependently inhibited $\beta$ -hexosamidase release.	[2]
Mouse Peritoneal Macrophages	LPS stimulation	1, 3, 10 $\mu$ M	Inhibited the induction of inducible nitric oxide synthase (iNOS) and cyclooxygenase 2 (COX-2).	[2]
BV-2 Microglia	LPS stimulation	Not specified	Reduced the production of IL-1 $\beta$ , IL-6, IL-12, and TNF- $\alpha$ .	[3]
BV-2 Microglia	LPS stimulation	Not specified	Increased the phosphorylation of AMP-activated protein kinase (AMPK).	[3]
BV-2 Microglia	LPS stimulation	Not specified	Upregulated Nrf2/ARE pathway-related downstream factors, NQO-1 and HO-1.	[3]

### 3.2.1. Mast Cell Degranulation Assay

RBL-2H3 mast cells were sensitized with anti-DNP IgE and then challenged with DNP-HSA to induce degranulation.[2] The release of  $\beta$ -hexosamidase into the supernatant was measured

as an index of degranulation.[2]

### 3.2.2. Macrophage and Microglia Culture and Stimulation

Mouse peritoneal macrophages and BV-2 microglia were stimulated with lipopolysaccharide (LPS) to induce an inflammatory response.[2][3]

### 3.2.3. Measurement of Inflammatory Mediators

The expression of iNOS and COX-2 in macrophages was determined by Western blotting.[2] The levels of pro-inflammatory cytokines (IL-1 $\beta$ , IL-6, IL-12, and TNF- $\alpha$ ) in the culture supernatants of microglia were measured by ELISA.[3]

### 3.2.4. Western Blot Analysis for Signaling Pathways

The phosphorylation status of AMPK and the expression levels of Nrf2, NQO-1, and HO-1 in BV-2 microglia were determined by Western blot analysis.[3]

The anti-neuroinflammatory effects of Bakkenolide B are mediated through the activation of the AMPK/Nrf2 signaling pathway.[3] LPS stimulation in microglia leads to an inflammatory response characterized by the production of pro-inflammatory cytokines. Bakkenolide B was found to increase the phosphorylation of AMPK, which in turn promotes the nuclear translocation of Nrf2.[3] In the nucleus, Nrf2 binds to the antioxidant response element (ARE) and upregulates the expression of antioxidant enzymes such as NQO-1 and HO-1, which have anti-inflammatory properties.[3]

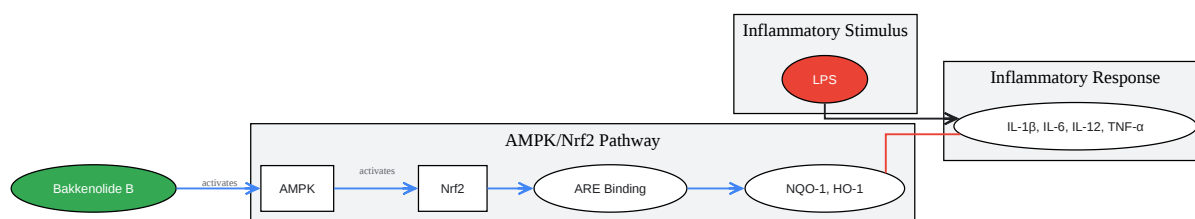

[Click to download full resolution via product page](#)

Caption: Bakkenolide B Anti-inflammatory Signaling Pathway.

## Conclusion

The preliminary in vitro studies on Bakkenolide B and Bakkenolide-IIIa provide compelling evidence for the potential therapeutic applications of the bakkenolide class of compounds. Their demonstrated neuroprotective and anti-inflammatory activities, mediated through the modulation of key signaling pathways such as NF- $\kappa$ B and AMPK/Nrf2, warrant further investigation. While specific in vitro data for **Bakkenolide D** is currently limited, the findings for its analogs suggest that it may possess similar bioactive properties. Future research should focus on elucidating the specific in vitro bioactivity profile of **Bakkenolide D** to fully understand its therapeutic potential. This technical guide serves as a foundational resource for researchers and drug development professionals interested in exploring the promising pharmacological properties of bakkenolides.

### Need Custom Synthesis?

BenchChem offers custom synthesis for rare earth carbides and specific isotopic labeling.

Email: [info@benchchem.com](mailto:info@benchchem.com) or [Request Quote Online](#).

## References

- [1. Bakkenolide-IIIa Protects Against Cerebral Damage Via Inhibiting NF- \$\kappa\$ B Activation - PubMed \[pubmed.ncbi.nlm.nih.gov\]](#)
- [2. Anti-allergic and anti-inflammatory effects of bakkenolide B isolated from Petasites japonicus leaves - PubMed \[pubmed.ncbi.nlm.nih.gov\]](#)
- [3. Petasites japonicus bakkenolide B inhibits lipopolysaccharide-induced pro-inflammatory cytokines via AMPK/Nrf2 induction in microglia - PubMed \[pubmed.ncbi.nlm.nih.gov\]](#)
- To cite this document: BenchChem. [Preliminary In Vitro Studies on Bakkenolide Bioactivity: A Technical Guide]. BenchChem, [2026]. [Online PDF]. Available at: [\[https://www.benchchem.com/product/b13384392/docs#preliminary-in-vitro-studies-on-bakkenolide-bioactivity-a-technical-guide\]](https://www.benchchem.com/product/b13384392/docs#preliminary-in-vitro-studies-on-bakkenolide-bioactivity-a-technical-guide)

**Disclaimer & Data Validity:**

The information provided in this document is for Research Use Only (RUO) and is strictly not intended for diagnostic or therapeutic procedures. While BenchChem strives to provide accurate protocols, we make no warranties, express or implied, regarding the fitness of this product for every specific experimental setup.

**Technical Support:** The protocols provided are for reference purposes. Unsure if this reagent suits your experiment?

**Need Industrial/Bulk Grade?** [Request Custom Synthesis Quote](#)

## BenchChem

Our mission is to be the trusted global source of essential and advanced chemicals, empowering scientists and researchers to drive progress in science and industry.

### Contact

Address: 3281 E Guasti Rd  
Ontario, CA 91761, United States  
Phone: (601) 213-4426  
Email: [info@benchchem.com](mailto:info@benchchem.com)

[Contact our Ph.D. Support Team for a compatibility check](#)