

Technical Support Center: Formyl Peptide Receptor (FPR) Binding Assays

Author: BenchChem Technical Support Team. **Date:** April 2026

Compound of Interest

Compound Name: *N-Formyl-Nle-Leu-Phe-Nle-Tyr-Lys*
Cat. No.: B13382085

[Get Quote](#)

This technical support center provides troubleshooting guidance and answers to frequently asked questions for researchers, scientists, and drug development professionals working with formyl peptide receptor (FPR) binding assays.

Troubleshooting Guides

This section addresses specific issues that may arise during FPR binding experiments, offering potential causes and solutions in a question-and-answer format.

Issue: High Background Signal

- Question: Why am I observing a high background signal in my FPR binding assay?
- Answer: A high background signal can obscure the specific binding signal, leading to a low signal-to-noise ratio. Potential causes include:
 - Non-specific binding: The labeled ligand may be binding to components other than the receptor, such as the assay plate, filter membranes, or other proteins in the sample.[1][2] This is a common issue with hydrophobic ligands.[3]

- Contaminated reagents: Buffer components or other reagents may be intrinsically fluorescent or contaminated with fluorescent substances.[4][5]
- Inappropriate microplate selection: Using white or clear plates for fluorescence-based assays can lead to high background fluorescence.[5]
- Excess tracer concentration: Using too high a concentration of the fluorescently labeled ligand (tracer) can increase background signal.[4]
- Solutions:
 - Optimize blocking agents: Include blocking agents like bovine serum albumin (BSA) or use non-binding surface plates to reduce non-specific binding to surfaces.[1][6] Note that some fluorophores may bind to BSA, so alternatives like bovine gamma globulin (BGG) might be necessary.[6]
 - Check reagent purity: Test individual assay components for intrinsic fluorescence and use high-purity reagents.
 - Use appropriate microplates: For fluorescence assays, use black, opaque microplates to minimize background fluorescence.[5]
 - Titrate tracer concentration: Determine the optimal tracer concentration that provides a good signal-to-noise ratio without elevating the background.[6] The fluorescence intensity of the tracer should be at least three times that of the buffer alone.[4]

Issue: Low Signal or No Signal

- Question: What are the possible reasons for a low or absent signal in my FPR binding assay?
- Answer: A weak or non-existent signal can be due to several factors related to the reagents, assay conditions, or instrumentation.
 - Inactive receptor: The formyl peptide receptors in your cell membranes or purified preparation may be inactive or present in very low concentrations.

- Degraded ligand: The radiolabeled or fluorescently labeled ligand may have degraded over time.
- Suboptimal assay conditions: Incubation time, temperature, or buffer composition (pH, ionic strength) may not be optimal for binding.[7]
- Instrument settings: Incorrect instrument settings, such as excitation and emission wavelengths for fluorescence assays, can lead to poor signal detection.[4]
- Insufficient tracer concentration: The concentration of the labeled ligand might be too low to generate a detectable signal.[4]
- Solutions:
 - Verify receptor activity: Use a positive control with a known potent ligand to confirm receptor activity. Ensure proper membrane preparation and storage to maintain receptor integrity.
 - Check ligand quality: Assess the purity and integrity of the labeled ligand. For radioligands, consider the specific activity and potential for radiolysis.[3]
 - Optimize assay conditions: Systematically vary incubation time, temperature, and buffer components to find the optimal conditions for binding.[7]
 - Optimize instrument settings: Ensure the instrument is correctly calibrated and the settings are appropriate for the specific fluorophore or radioisotope being used.[4]
 - Increase tracer concentration: If the signal is too low, consider increasing the tracer concentration, but be mindful of potential increases in non-specific binding.[4]

Issue: Poor Reproducibility

- Question: Why are my results inconsistent between experiments?
- Answer: Lack of reproducibility can stem from variability in experimental technique and reagent preparation.

- Inconsistent reagent preparation: Variations in the concentration of receptors, ligands, or buffer components between assays.
- Pipetting errors: Inaccurate or inconsistent pipetting, especially with small volumes.
- Fluctuations in experimental conditions: Variations in incubation temperature and time.[7]
- Cell passage number: For cell-based assays, receptor expression levels can change with cell passage number.
- Solutions:
 - Standardize protocols: Prepare fresh reagents for each experiment and use calibrated pipettes.
 - Maintain consistent conditions: Use a temperature-controlled incubator and a precise timer for all incubation steps.[7]
 - Monitor cell culture: Use cells within a defined passage number range to ensure consistent receptor expression.

Frequently Asked Questions (FAQs)

This section provides answers to common questions regarding the practical aspects of FPR binding assays.

- Question: What are the different types of FPR binding assays?
- Answer: The most common types of FPR binding assays are:
 - Radioligand Binding Assays: These are considered the gold standard for their sensitivity and robustness.[8] They involve incubating a radiolabeled ligand with the receptor and then separating the bound from the unbound ligand, typically by filtration.[3][9]
 - Fluorescence Polarization (FP) Assays: This is a homogeneous assay format suitable for high-throughput screening.[10] It measures the change in the polarization of fluorescent light when a small fluorescently labeled ligand binds to a larger receptor molecule.[11]

- Förster Resonance Energy Transfer (FRET) Assays: FRET-based assays measure the energy transfer between a donor and an acceptor fluorophore that are in close proximity when a ligand binds to the receptor.[12][13]
- Question: How do I choose the right labeled ligand for my assay?
- Answer: The choice of labeled ligand is critical for a successful binding assay. Key considerations include:
 - High affinity and specificity: The ligand should bind to the target receptor with high affinity and minimal binding to other receptors.
 - For Radioligands: High specific activity is important for sensitivity.[3]
 - For Fluorescent Ligands: The fluorophore should have a high quantum yield and be stable under assay conditions.[7] The choice of fluorophore can also help to avoid interference from fluorescent library compounds in screening assays.[14]
- Question: What controls should I include in my FPR binding assay?
- Answer: Appropriate controls are essential for interpreting the results of your binding assay.
 - Total binding: Measures the total amount of labeled ligand bound to the receptor preparation.
 - Non-specific binding: Determined by incubating the receptor and labeled ligand in the presence of a high concentration of an unlabeled ligand that saturates the specific binding sites.[1]
 - Specific binding: Calculated by subtracting the non-specific binding from the total binding.
 - Positive control: A known agonist or antagonist for the receptor to validate the assay performance.
 - Negative control: A vehicle or buffer control without any test compound.

Data Presentation

Table 1: Typical Experimental Parameters for FPR Binding Assays

Parameter	Radioligand Binding Assay	Fluorescence Polarization Assay
Incubation Temperature	25-37°C	Room Temperature
Incubation Time	30-120 minutes	1-4 hours[15]
Buffer System	Tris-HCl, HEPES	HEPES, PBS
pH	7.4	7.4
Protein Concentration	10-100 μ g/well	Varies based on receptor expression
Labeled Ligand Conc.	At or below K_d [3]	Typically 1-10 nM
Unlabeled Ligand Conc.	100-1000 fold excess over labeled ligand	Varies for IC50 determination

Experimental Protocols

Protocol 1: Radioligand Filtration Binding Assay

- Membrane Preparation: Homogenize cells or tissues expressing FPRs in a cold lysis buffer and pellet the membranes by centrifugation.[9] Resuspend the membrane pellet in a suitable assay buffer.
- Assay Setup: In a 96-well plate, add the membrane preparation, radiolabeled ligand (e.g., ^3H -fMLF), and either buffer (for total binding) or a high concentration of unlabeled fMLF (for non-specific binding).[9] For competition assays, add varying concentrations of the test compound.
- Incubation: Incubate the plate at the optimized temperature and time with gentle agitation.[9]
- Filtration: Rapidly filter the contents of each well through a glass fiber filter mat using a cell harvester to separate bound from free radioligand.[3][9]

- **Washing:** Wash the filters multiple times with ice-cold wash buffer to remove unbound radioligand.[9]
- **Detection:** Dry the filters, add scintillation cocktail, and count the radioactivity using a scintillation counter.[9]

Protocol 2: Fluorescence Polarization (FP) Binding Assay

- **Reagent Preparation:** Prepare solutions of the fluorescently labeled FPR ligand (tracer) and the receptor preparation (e.g., cell membranes or purified receptor) in an appropriate assay buffer.[7]
- **Assay Setup:** In a black 384-well microplate, add the tracer, receptor preparation, and either buffer or varying concentrations of the test compound.[16]
- **Incubation:** Incubate the plate at room temperature for a sufficient time to reach binding equilibrium.[7][15]
- **Measurement:** Measure the fluorescence polarization using a plate reader equipped with appropriate excitation and emission filters for the chosen fluorophore.[7]

Mandatory Visualizations

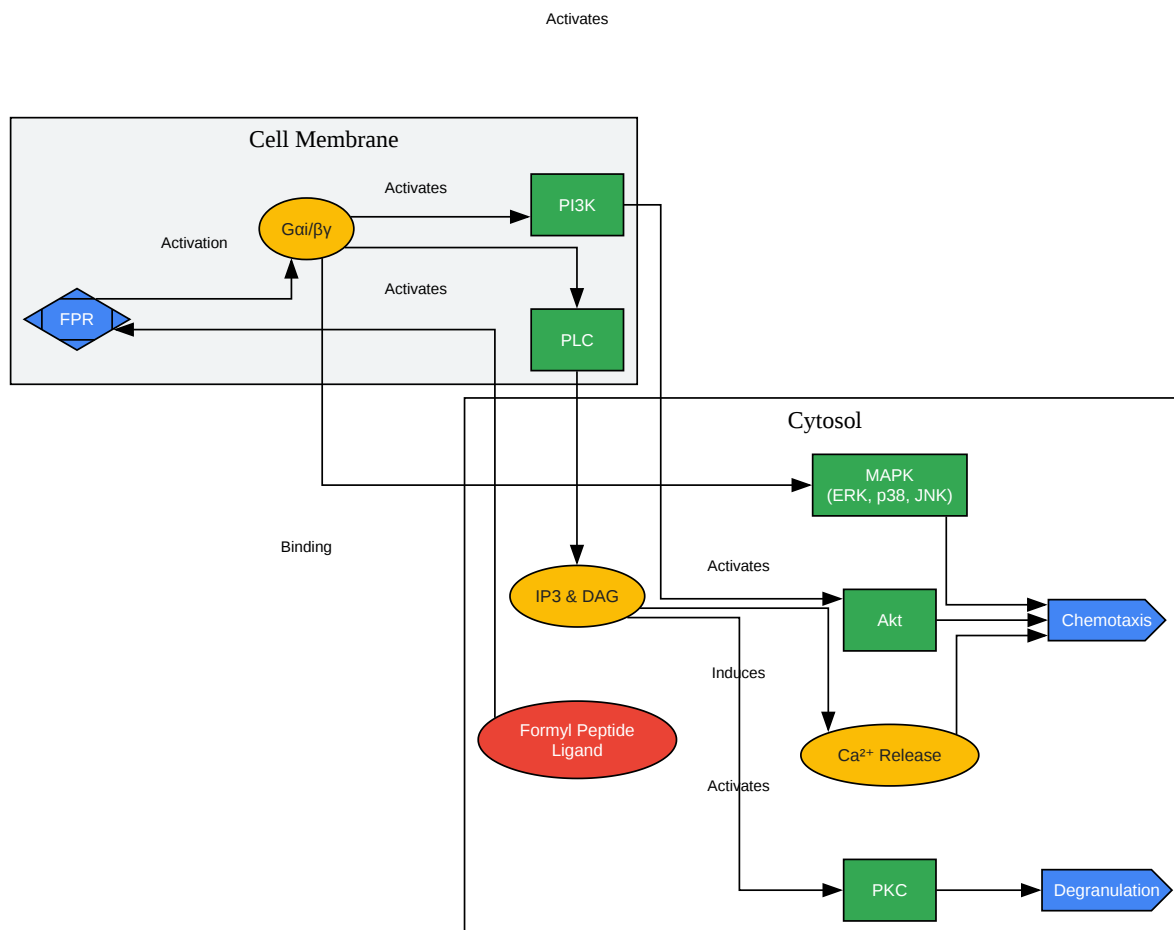

[Click to download full resolution via product page](#)

Caption: Simplified signaling pathway of Formyl Peptide Receptors (FPRs).^{[17][18][19]}

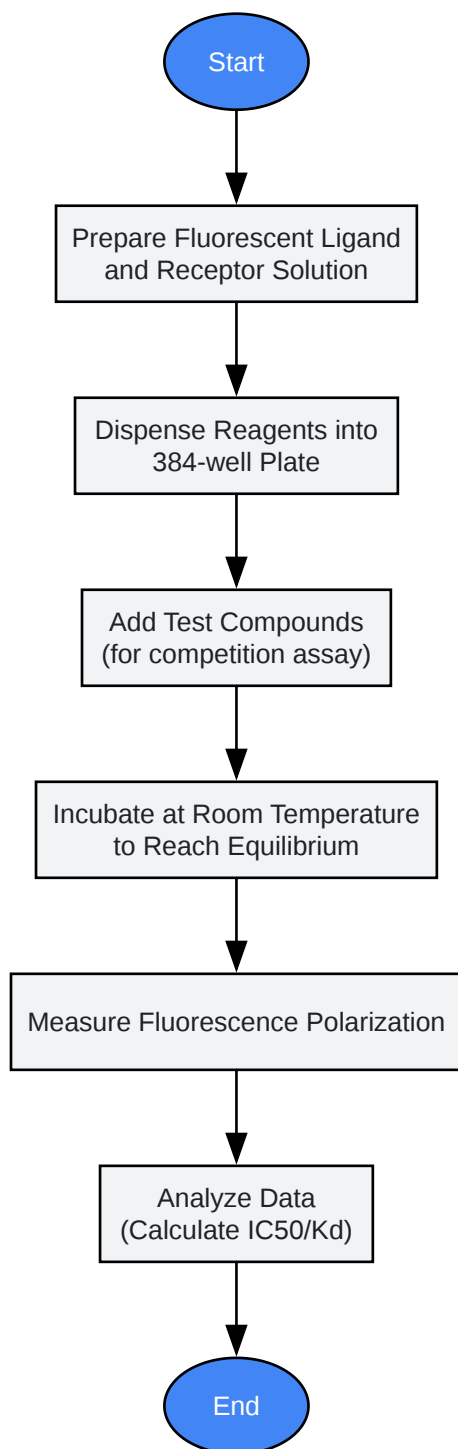

[Click to download full resolution via product page](#)

Caption: General workflow for a fluorescence polarization (FP) based FPR binding assay.

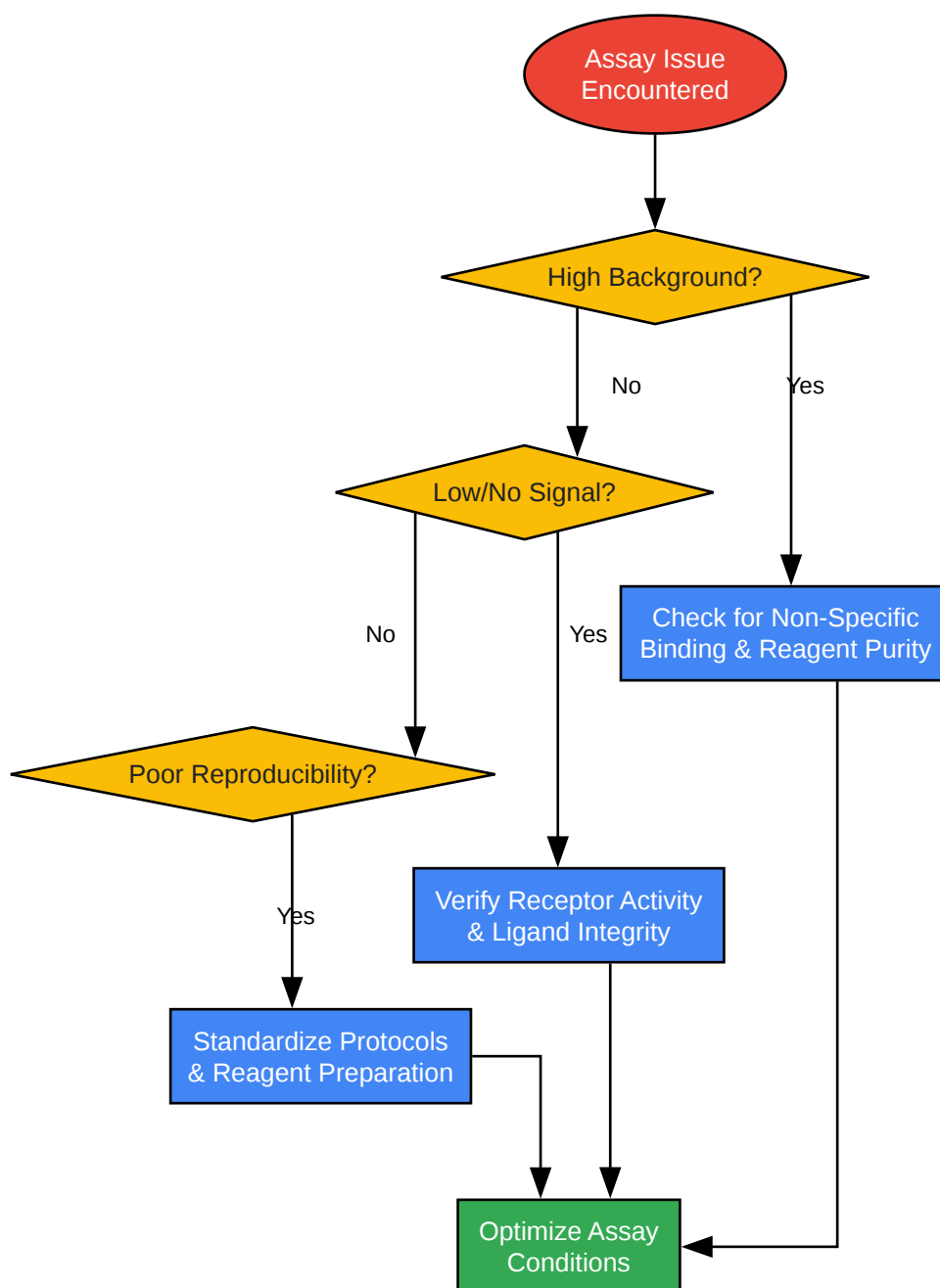

[Click to download full resolution via product page](#)

Caption: A logical troubleshooting workflow for common FPR binding assay issues.

Need Custom Synthesis?

BenchChem offers custom synthesis for rare earth carbides and specific isotopic labeling.

Email: info@benchchem.com or [Request Quote Online](#).

References

- [1. Surmodics - Non-Specific Binding: What You Need to Know \[shop.surmodics.com\]](#)
- [2. Nonspecific Binding: Main Factors of Occurrence and Strategies - WuXi AppTec DMPK \[dmpkservice.wuxiapptec.com\]](#)
- [3. revvity.com \[revvity.com\]](#)
- [4. benchchem.com \[benchchem.com\]](#)
- [5. researchgate.net \[researchgate.net\]](#)
- [6. Establishing and optimizing a fluorescence polarization assay \[moleculardevices.com\]](#)
- [7. Fluorescence Polarization Assay Protocol: A Step-by-Step Guide for Accurate Measurements - nanomicronspheres \[nanomicronspheres.com\]](#)
- [8. giffordbioscience.com \[giffordbioscience.com\]](#)
- [9. giffordbioscience.com \[giffordbioscience.com\]](#)
- [10. pubs.acs.org \[pubs.acs.org\]](#)
- [11. researchgate.net \[researchgate.net\]](#)
- [12. spectroscopyonline.com \[spectroscopyonline.com\]](#)
- [13. Flow cytometry based-FRET: basics, novel developments and future perspectives - PMC \[pmc.ncbi.nlm.nih.gov\]](#)
- [14. Avoiding Fluorescence Assay Interference—The Case for Diaphorase - PMC \[pmc.ncbi.nlm.nih.gov\]](#)
- [15. documents.thermofisher.com \[documents.thermofisher.com\]](#)
- [16. rsc.org \[rsc.org\]](#)
- [17. Distinct Signaling Cascades Elicited by Different Formyl Peptide Receptor 2 \(FPR2\) Agonists - PMC \[pmc.ncbi.nlm.nih.gov\]](#)
- [18. Formyl peptide receptor - Wikipedia \[en.wikipedia.org\]](#)
- [19. The Role of Formylated Peptides and Formyl Peptide Receptor 1 in Governing Neutrophil Function during Acute Inflammation - PMC \[pmc.ncbi.nlm.nih.gov\]](#)
- [To cite this document: BenchChem. \[Technical Support Center: Formyl Peptide Receptor \(FPR\) Binding Assays\]. BenchChem, \[2026\]. \[Online PDF\]. Available at: \[https://www.benchchem.com/product/b13382085/docs#technical-support-center-formyl-peptide-receptor-fpr-binding-assays\]](#)

Disclaimer & Data Validity:

The information provided in this document is for Research Use Only (RUO) and is strictly not intended for diagnostic or therapeutic procedures. While BenchChem strives to provide accurate protocols, we make no warranties, express or implied, regarding the fitness of this product for every specific experimental setup.

Technical Support: The protocols provided are for reference purposes. Unsure if this reagent suits your experiment?

Need Industrial/Bulk Grade? [Request Custom Synthesis Quote](#)

BenchChem

Our mission is to be the trusted global source of essential and advanced chemicals, empowering scientists and researchers to drive progress in science and industry.

Contact

Address: 3281 E Guasti Rd
Ontario, CA 91761, United States
Phone: (601) 213-4426
Email: info@benchchem.com

[Contact our Ph.D. Support Team for a compatibility check](#)