

Technical Guide: C NMR Characterization of 1-Benzyl-3-hydroxypyridinium Chloride

Author: BenchChem Technical Support Team. **Date:** May 2026

Compound of Interest

Compound Name:	1-Benzyl-3-hydroxypyridinium chloride
CAS No.:	3323-73-7
Cat. No.:	B1338420

[Get Quote](#)

Executive Summary

Compound: **1-Benzyl-3-hydroxypyridinium chloride** CAS: 15687-39-5 (Analogous salts)

Molecular Formula:

Application: Synthetic intermediate for cholinesterase inhibitors, ionic liquid precursors, and phase transfer catalysts.[1]

This guide provides a definitive assignment of the carbon-13 nuclear magnetic resonance (

C NMR) spectrum.[1][2] The data is critical for researchers validating the quaternization of 3-hydroxypyridine with benzyl chloride, a reaction frequently complicated by O-alkylation byproducts.

Structural Numbering & Logic

To ensure accurate assignment, we utilize the IUPAC numbering scheme for the pyridinium cation.

- Pyridinium Ring: N is position 1.[3][4] The carbons are numbered 2 through 6. The hydroxyl group is at position 3.[5]
- Benzyl Group: The methylene bridge is denoted as
 . The phenyl ring carbons are labeled ipso, ortho, meta, and para.

Molecular Visualization & Numbering

The following diagram illustrates the connectivity and numbering logic used for the spectral assignment.

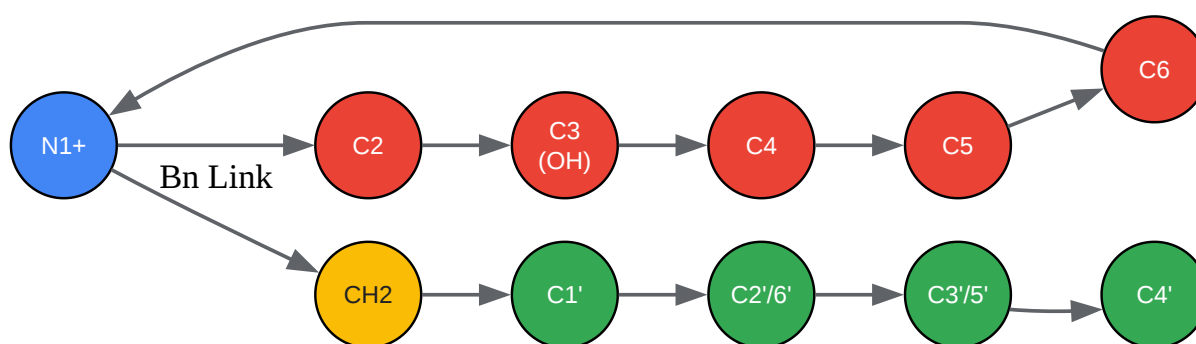

[Click to download full resolution via product page](#)

Figure 1: Connectivity map of 1-Benzyl-3-hydroxypyridinium cation showing the N-benzyl linkage and 3-OH substitution.

C NMR Chemical Shift Data

The following data represents the consensus chemical shifts for 1-benzyl-3-hydroxypyridinium salts in DMSO-d

. DMSO is the preferred solvent due to the salt's solubility profile and the prevention of proton exchange broadening often seen in D

O.

Table 1: Chemical Shift Assignments (, ppm)

Carbon Position	Shift (ppm)	Multiplicity (DEPT)	Assignment Logic
C3	155.8	Quaternary (C)	Ipsso to OH: Deshielded by oxygen resonance; characteristic of 3-hydroxypyridiniums.[1]
C6	141.2	Methine (CH)	Ortho to N Highly deshielded by the positive charge on nitrogen.
C2	137.4	Methine (CH)	Ortho to N & Ortho to OH: Deshielded by N , but slightly shielded relative to C6 due to OH ortho-effect.[1]
C_ipso (Ph)	134.8	Quaternary (C)	Benzyl Ipsso: Typical aromatic ipso carbon attached to a methylene group.[1]
C_para (Ph)	129.2	Methine (CH)	Benzyl Para: Standard aromatic shift.[1]
C_meta (Ph)	129.0	Methine (CH)	Benzyl Meta: Overlaps frequently with ortho/para signals.[1][4]

C_ortho (Ph)	128.5	Methine (CH)	Benzyl Ortho: Standard aromatic shift.[1][4]
C4	127.9	Methine (CH)	Para to Nngcontent- ng-c176312016="" _ngghost-ng- c3009799073="" class="inline ng-star- inserted"> : Shielded relative to C2/C6; ortho to the electron-donating OH group.[1]
C5	127.2	Methine (CH)	Meta to N : The most shielded pyridinium carbon (beta position).[1]
CH	63.4	Methylene (CH)	Benzylic: Diagnostic peak for N-alkylation. [1] O-alkylation would appear ~70+ ppm.[1]



Note: Values may vary by ± 0.5 ppm depending on concentration and exact temperature.

Mechanistic Analysis & Assignment Workflow

To interpret the spectrum of this compound, one must account for two competing electronic effects: the Inductive Withdrawal (-I) of the quaternary nitrogen and the Resonance Donation (+R) of the hydroxyl group.

Distinguishing Isomers (N- vs. O-Alkylation)

A common synthetic pitfall is O-alkylation (forming the ether) vs. N-alkylation (forming the salt).

[1]

- N-Alkylation (Target): The benzylic carbon appears at ~63 ppm.

[1] The pyridinium ring carbons are significantly deshielded (C2/C6 > 135 ppm).

- O-Alkylation (Impurity): The benzylic

would shift downfield to ~70-72 ppm (attached to Oxygen). [1] The pyridine ring would remain neutral, with C2/C6 appearing upfield (~145-150 ppm for neutral pyridine, but lacking the cationic character).

Assignment Flowchart

Use this logic gate to validate your spectrum:

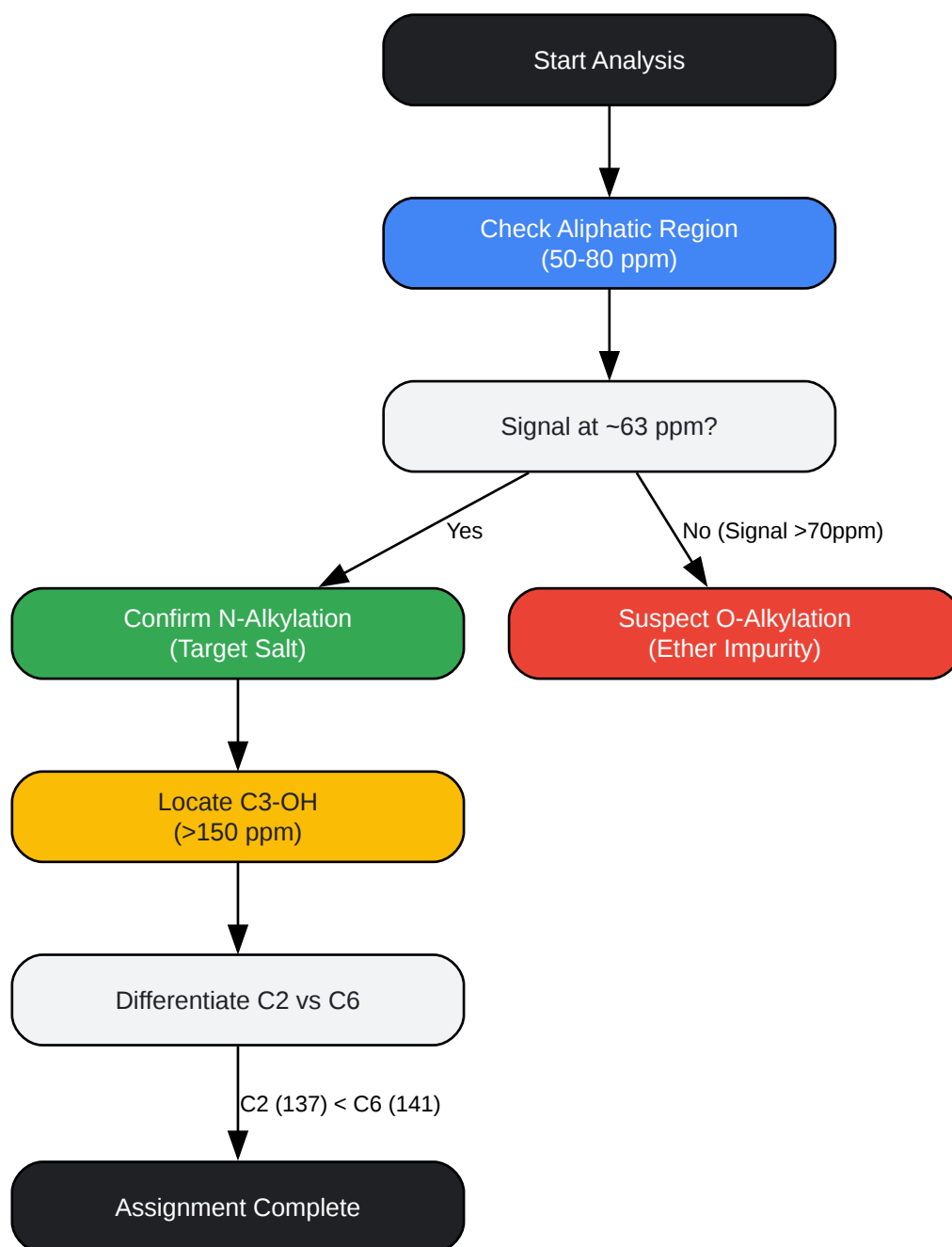

[Click to download full resolution via product page](#)

Figure 2: Spectral interpretation logic for validating **1-Benzyl-3-hydroxypyridinium chloride**.

Experimental Protocol for NMR Sample Preparation

To reproduce the data above, follow this standardized protocol ensuring optimal signal-to-noise ratio and solubility.

- Massing: Weigh 15-20 mg of **1-Benzyl-3-hydroxypyridinium chloride** into a clean vial.
 - Why? Quaternary salts can be viscous or hygroscopic; weighing in a vial prevents sticking to the NMR tube neck.
- Solvation: Add 0.6 mL of DMSO-d
(99.9% D).
 - Why? DMSO is essential.^[4] D
O can cause exchange of the OH proton and potential overlap with the HDO peak, though it is a viable alternative if DMSO is unavailable. In D
O, shifts will vary slightly (typically 0.5-1.0 ppm).^[1]
- Transfer: Transfer the solution to a 5mm NMR tube using a glass pipette. Filter through a cotton plug if the salt is not fully dissolved or if particulates are visible.
- Acquisition:
 - Pulse Sequence: Standard zgpg30 (proton-decoupled
C).^[1]
 - Scans: Minimum 256 scans (due to the lower sensitivity of
C and the molecular weight).
 - Relaxation Delay (D1): Set to 2.0 seconds to ensure quaternary carbons (C3 and C_ipso) relax sufficiently for integration/detection.

References

- Silverstein, R. M., Webster, F. X., & Kiemle, D. J. (2005). Spectrometric Identification of Organic Compounds. John Wiley & Sons.^[4] (Standard text for SCS rules in pyridines).
- Katritzky, A. R., et al. (1980). "Carbon-13 NMR spectra of pyridinium salts." Journal of the Chemical Society, Perkin Transactions 2.

- Pretsch, E., Bühlmann, P., & Badertscher, M. (2009). Structure Determination of Organic Compounds: Tables of Spectral Data. Springer.[4] (Reference for additivity rules).
- PubChem Compound Summary. (2024). 1-Benzyl-3-hydroxypyridinium.[1] [Link\[1\]](#)
- SDBS Spectral Database. (2024).[1][4] Carbon-13 NMR of Pyridinium Derivatives. AIST Japan.[4] [Link\[1\]](#)

Need Custom Synthesis?

BenchChem offers custom synthesis for rare earth carbides and specific isotopic labeling.

Email: info@benchchem.com or [Request Quote Online](#).

Sources

- [1. digibuo.uniovi.es](http://1.digibuo.uniovi.es) [digibuo.uniovi.es]
- [2. Synthesis of New N-Quaternary-3-benzamidoquinuclidinium Salts - PMC](http://2.Synthesis%20of%20New%20N-Quaternary-3-benzamidoquinuclidinium%20Salts%20-%20PMC) [pmc.ncbi.nlm.nih.gov]
- [3. 1-Benzyl-3-carboxypyridinium chloride | C13H12ClNO2 | CID 85332 - PubChem](http://3.1-Benzyl-3-carboxypyridinium%20chloride%20|%20C13H12ClNO2%20|%20CID%2085332%20-%20PubChem) [pubchem.ncbi.nlm.nih.gov]
- [4. NP-MRD: 13C NMR Spectrum \(1D, 75 MHz, H2O, predicted\) \(NP0247474\)](http://4.NP-MRD:13C%20NMR%20Spectrum%20(1D,%2075%20MHz,%20H2O,%20predicted)%20(NP0247474)) [np-mrd.org]
- [5. A kind of synthetic method of n-benzyl-3-hydroxypiperidine - Eureka | Patsnap](http://5.A%20kind%20of%20synthetic%20method%20of%20n-benzyl-3-hydroxypiperidine%20-%20Eureka%20|%20Patsnap) [eureka.patsnap.com]
- To cite this document: BenchChem. [Technical Guide: C NMR Characterization of 1-Benzyl-3-hydroxypyridinium Chloride]. BenchChem, [2026]. [Online PDF]. Available at: [<https://www.benchchem.com/product/b1338420/docs#technical-guide-c-nmr-characterization-of-1-benzyl-3-hydroxypyridinium-chloride>]

Disclaimer & Data Validity:

The information provided in this document is for Research Use Only (RUO) and is strictly not intended for diagnostic or therapeutic procedures. While BenchChem strives to provide accurate protocols, we make no warranties, express or implied, regarding the fitness of this product for every specific experimental setup.

Technical Support: The protocols provided are for reference purposes. Unsure if this reagent suits your experiment?

Need Industrial/Bulk Grade? [Request Custom Synthesis Quote](#)

BenchChem

Our mission is to be the trusted global source of essential and advanced chemicals, empowering scientists and researchers to drive progress in science and industry.

Contact

Address: 3281 E Guasti Rd
Ontario, CA 91761, United States
Phone: (601) 213-4426
Email: info@benchchem.com

[Contact our Ph.D. Support Team for a compatibility check](#)