

# Comparative Technical Guide: -Ethyl vs. -Methyl 3-Nitrocinnamic Acid

**Author:** BenchChem Technical Support Team. **Date:** April 2026

## Compound of Interest

Compound Name: *alpha-Ethyl-3-nitrocinnamic acid*

CAS No.: 5253-02-1

Cat. No.: B1337043

[Get Quote](#)

## Part 1: Executive Summary

The structural modification of cinnamic acid derivatives at the

-position significantly alters their steric profile, crystal packing, and biological interaction mechanisms.

- -Ethyl-3-nitrocinnamic acid (CAS 124525-55-9) presents a bulkier steric shield, influencing enzyme binding pockets and lowering metabolic susceptibility compared to its methyl analogue.
- -Methyl-3-nitrocinnamic acid serves as the lower homologue, offering a balance between steric obstruction and planarity, often used as a probe for steric tolerance in Structure-Activity Relationship (SAR) studies.

Both compounds are synthesized via the Perkin Reaction, but the choice of anhydride (butyric vs. propionic) dictates the alkyl outcome.

## Part 2: Physicochemical & Structural Analysis[1]

## Structural Divergence

The core difference lies in the alkyl substituent at the vinylic

-carbon.

- -Methyl Group (-CH<sub>3</sub>)

): Introduces moderate steric strain. The molecule retains a degree of planarity capable of

-

stacking, though less than unsubstituted cinnamic acid.

- -Ethyl Group (-CH<sub>2</sub>CH<sub>3</sub>)

CH<sub>2</sub>

): The additional methylene unit increases the A-value (steric bulk), forcing the phenyl ring to twist out of coplanarity with the carbonyl system to minimize allylic strain (

strain). This twist reduces conjugation efficiency and alters UV absorption maxima.

## Quantitative Comparison Table

Feature	-Ethyl-3-nitrocinnamic Acid	-Methyl-3-nitrocinnamic Acid
CAS Number	124525-55-9	Not widely listed as acid (Check ester: 1664-59-1)
Molecular Formula	C	C
	H	H
	NO	NO
Molecular Weight	221.21 g/mol	193.16 g/mol
Melting Point	138–142 °C	~145–160 °C (Predicted/Analogue trend*)
Lipophilicity (cLogP)	High (>2.8)	Moderate (~2.[1]3)
Electronic Effect	+I (Inductive), Steric dominant	+I (Inductive), Steric moderate
Key Precursor	Butyric Anhydride	Propionic Anhydride

\*Note: Unsubstituted

-methylcinnamic acid melts at 79°C, while 3-nitrocinnamic acid melts at ~200°C. The nitro group raises MP via intermolecular H-bonding/dipole interactions, while the alkyl group lowers it by disrupting packing.

## Part 3: Synthetic Pathways (The Perkin Reaction)[3]

The synthesis of both analogues relies on the Perkin Condensation, a base-catalyzed aldol-type condensation between an aromatic aldehyde and an acid anhydride.[2]

### Reaction Mechanism Logic[5][6]

- Enolization: The base (sodium salt of the acid) deprotonates the  $\alpha$ -position of the anhydride.[3]

- Nucleophilic Attack: The anhydride enolate attacks the aldehyde carbonyl (3-nitrobenzaldehyde).
- Acylation & Elimination: The resulting alkoxide is acylated, followed by E2 elimination (dehydration) and hydrolysis to yield the free acid.

## Critical Divergence

- To synthesize the  
-Ethyl derivative, Butyric Anhydride must be used.
- To synthesize the  
-Methyl derivative, Propionic Anhydride must be used.

## Visualization: Synthesis Workflow

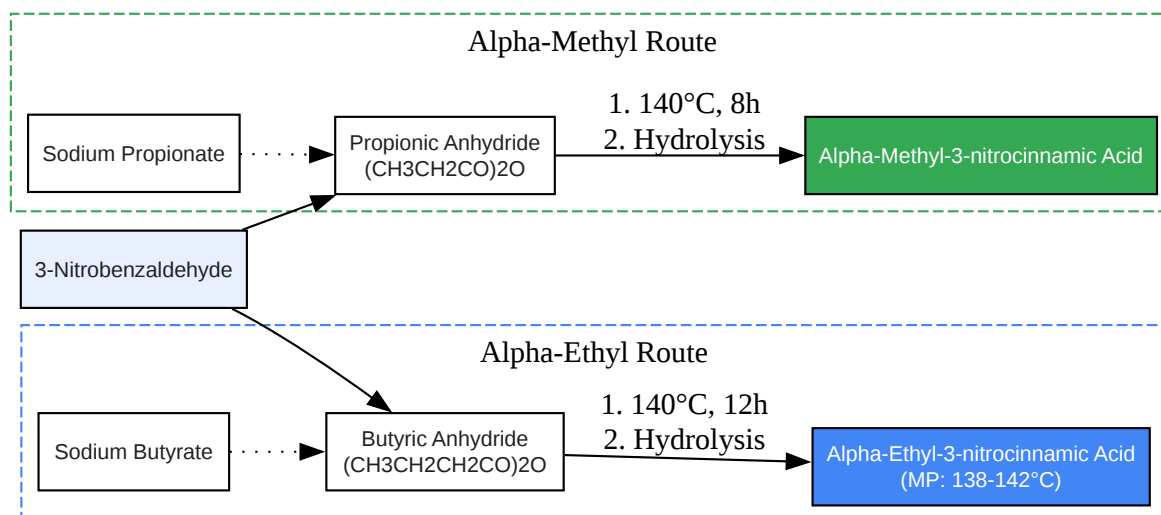

[Click to download full resolution via product page](#)

Caption: Divergent synthesis pathways via Perkin Condensation. The anhydride carbon chain length determines the

-substituent.

## Part 4: Experimental Protocols

### Protocol A: Synthesis of -Ethyl-3-nitrocinnamic Acid

Objective: Produce high-purity crystalline acid using the Perkin method.

- Reagent Setup:
  - 3-Nitrobenzaldehyde: 15.1 g (0.1 mol)
  - Butyric Anhydride: 25.0 mL (Excess)
  - Sodium Butyrate (Anhydrous): 11.0 g (Catalyst)
- Reaction:
  - Combine reagents in a round-bottom flask equipped with a drying tube (moisture sensitive).
  - Heat the mixture in an oil bath at 140–150 °C for 8–12 hours. The high temperature is required to overcome the steric hindrance of the forming ethyl group.
- Work-up:
  - Pour the hot reaction mixture into excess water (500 mL) to hydrolyze the remaining anhydride.
  - Steam distill to remove unreacted 3-nitrobenzaldehyde (if necessary).
  - Basify with saturated Na  
CO  
to dissolve the cinnamic acid as its salt. Filter off any insoluble impurities.
- Isolation:
  - Acidify the filtrate with concentrated HCl. The

-ethyl-3-nitrocinnamic acid will precipitate as a solid.

- Recrystallization: Recrystallize from Ethanol/Water (70:30) to yield pale yellow crystals.[4]
- Validation: Check Melting Point (Target: 138–142 °C).

## Protocol B: Synthesis of -Methyl-3-nitrocinnamic Acid

Follow Protocol A, but substitute Propionic Anhydride and Sodium Propionate.

- Note: Reaction times may be slightly shorter (6–8 hours) due to lower steric hindrance of the methyl group compared to the ethyl.

## Part 5: Mechanistic & Biological Implications

### Steric Interference in Drug Design

The transition from methyl to ethyl at the

-position is a classic strategy in Lead Optimization:

- Conformational Lock: The ethyl group forces the phenyl ring to rotate, potentially locking the molecule in a bioactive conformation that fits a specific hydrophobic pocket.

- Metabolic Stability: The

-ethyl group blocks metabolic attack at the double bond (e.g., reduction or epoxidation) more effectively than a methyl group due to steric shielding.

## Reactivity Profile (Michael Addition)

Both compounds are Michael Acceptors (electrophiles). However, the

-ethyl derivative reacts significantly slower with nucleophiles (like glutathione in biological systems) due to the shielding of the

-carbon.

- Reactivity Order: Unsubstituted >

-Methyl >

-Ethyl.

- Implication: The ethyl derivative is likely less toxic (lower risk of non-specific covalent binding) but may require higher potency to achieve efficacy.

## Visualization: Steric & Reactivity Comparison

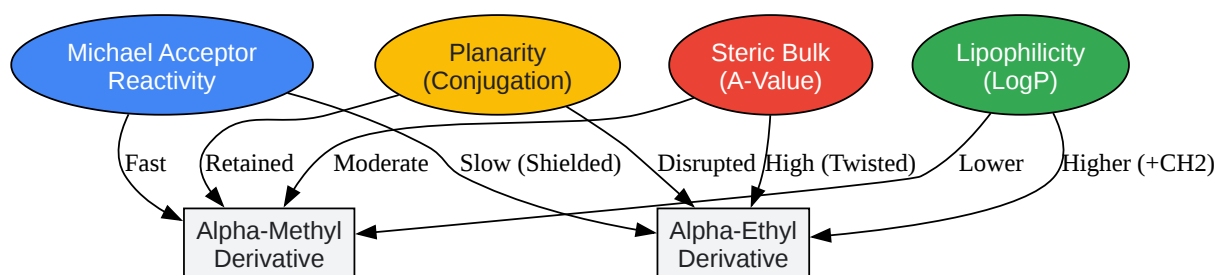

[Click to download full resolution via product page](#)

Caption: SAR Map illustrating the trade-offs between steric bulk, reactivity, and lipophilicity.

## References

- Thermo Fisher Scientific. (2025). Safety Data Sheet: **alpha-Ethyl-3-nitrocinnamic acid**. Retrieved from
- Alfa Chemistry. (2025).[5] Product Analysis: CAS 124525-55-9 Properties. Retrieved from
- Perkin, W. H. (1868). "On the artificial production of coumarin and formation of its homologues". *Journal of the Chemical Society*, 21, 53–61. (Foundational Chemistry).[6]
- NIST Chemistry WebBook. 3-Nitrocinnamic acid Spectral Data. Retrieved from
- Indian Journal of Pharmaceutical Sciences. (1998). Studies on the Synthesis of 3-Nitrobenzaldehyde and Derivatives. Retrieved from

### Need Custom Synthesis?

BenchChem offers custom synthesis for rare earth carbides and specific isotopic labeling.

Email: [info@benchchem.com](mailto:info@benchchem.com) or [Request Quote Online](#).

## Sources

- 1. Making sure you're not a bot! [[oc-praktikum.de](http://oc-praktikum.de)]
- 2. [byjus.com](http://byjus.com) [[byjus.com](http://byjus.com)]
- 3. [m.youtube.com](http://m.youtube.com) [[m.youtube.com](http://m.youtube.com)]
- 4. [ijpsonline.com](http://ijpsonline.com) [[ijpsonline.com](http://ijpsonline.com)]
- 5. [fishersci.com](http://fishersci.com) [[fishersci.com](http://fishersci.com)]
- 6. Cinnamic acid - Wikipedia [[en.wikipedia.org](http://en.wikipedia.org)]
- To cite this document: BenchChem. [Comparative Technical Guide: -Ethyl vs. -Methyl 3-Nitrocinnamic Acid]. BenchChem, [2026]. [Online PDF]. Available at: [<https://www.benchchem.com/product/b1337043/docs#comparative-technical-guide-ethyl-vs-methyl-3-nitrocinnamic-acid>]

---

### Disclaimer & Data Validity:

The information provided in this document is for Research Use Only (RUO) and is strictly not intended for diagnostic or therapeutic procedures. While BenchChem strives to provide accurate protocols, we make no warranties, express or implied, regarding the fitness of this product for every specific experimental setup.

**Technical Support:** The protocols provided are for reference purposes. Unsure if this reagent suits your experiment?

**Need Industrial/Bulk Grade?** [Request Custom Synthesis Quote](#)

# BenchChem

Our mission is to be the trusted global source of essential and advanced chemicals, empowering scientists and researchers to drive progress in science and industry.

## Contact

Address: 3281 E Guasti Rd

Ontario, CA 91761, United States

Phone: (601) 213-4426

Email: [info@benchchem.com](mailto:info@benchchem.com)

[Contact our Ph.D. Support Team for a compatibility check](#)